

WIPO MAGAZINE

AUGUST 2017

No. 4



Copyright exceptions: an archivist's perspective

p. 16

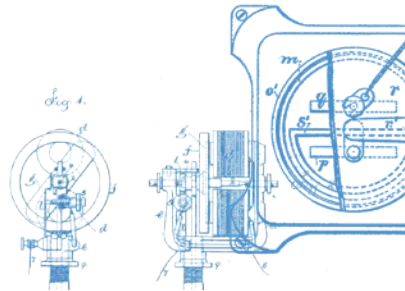

Twelve strategies to manage global patent costs

p. 37



Clean water for all: the quest of a Swiss water entrepreneur

p. 20



Protecting traditional cultural expressions – some questions for lawmakers

p. 8

Table of Contents

2	Factoring gender into innovation for better outcomes
8	Protecting traditional cultural expressions – some questions for lawmakers
16	Copyright exceptions: an archivist’s perspective
20	Clean water for all: the quest of a Swiss water entrepreneur
26	Trademarks and China’s business reform agenda
30	Intellectual property and development: the ASEAN story
37	Twelve strategies to manage global patent costs
42	In the courts: United States Supreme Court rewrites rules on patent exhaustion

Acknowledgements:

2	Julio Raffo , Economics and Statistics Division, WIPO
8	Daphné Zografos Johnsson , Traditional Knowledge Division, WIPO
20	Anja von der Ropp , Global Challenges Division, and Christine Bonvallet , PCT Legal Division, WIPO
26	Hongbing Chen , WIPO Office in China
30	Andrew Michael Ong , Regional Bureau for Asia and the Pacific, WIPO
37	Matthew Bryan , PCT Legal Division, WIPO
42	Marco Aleman , Patent Law Division, WIPO

Editor: **Catherine Jewell**

© WIPO, 2017



Attribution 3.0 IGO
license (CC BY 3.0 IGO)

The user is allowed to reproduce, distribute, adapt, translate and publicly perform this publication, including for commercial purposes, without explicit permission, provided that the content is accompanied by an acknowledgement that WIPO is the source and that it is clearly indicated if changes were made to the original content.

Adaptation/translation/derivatives should not carry any official emblem or logo, unless they have been approved and validated by WIPO. Please contact us via the WIPO website to obtain permission.

When content published by WIPO, such as images, graphics, trademarks or logos, is attributed to a third party, the user of such content is solely responsible for clearing the rights with the right holder(s).

To view a copy of this license, please visit <https://creativecommons.org/licenses/by/3.0/igo>

Cover images:

Left to right: David Bagnall / Alamy Stock Photo; patent drawing image CC0; iStock.com/© DJMattaar

Main image:

imageBROKER / Alamy Stock Photo

Factoring gender into innovation for better outcomes

By **Eleanor Khonje**,
freelance writer



Photo: Linda Cicero

Heart disease is a leading cause of death among women in the United States and Europe. Yet for many years it was considered a male condition, and clinical research focused almost exclusively on the functional changes that occur in male patients. As a consequence, many women were wrongly diagnosed.

Similarly, osteoporosis is considered a predominantly female condition. Men are rarely evaluated or treated for it. But after age 75, men suffer nearly one-third of hip fractures related to the condition in the United States and Europe.

These examples illustrate why it is important for scientists, engineers and other researchers to factor sex and gender – and the differential impact that research may have on both women and men – into their research protocols and development work.

WIPO Magazine recently sat down with Professor Londa Schiebinger, John L. Hinds Professor of History of Science and Director of Gendered Innovations in Science, Health and Medicine, Engineering and Environment at Stanford University in the United States, to find out more about why sex and gender need to be taken seriously by researchers, engineers and inventors.

What prompted you to start the Gendered Innovations project?

I have always been interested in the role that gender plays in the cultural production of knowledge. And I wanted to develop a practical tool that demonstrates that by integrating sex and gender analysis into scientific, medical and environmental research, you create new knowledge

and bring about positive change. Gendered Innovations is all about discovery and innovation, and focuses on improving research and making it more inclusive.

Tell us more about the project.

Gendered Innovations is an analytical framework developed by an international collaboration of experts including over 80 scientists, humanists and gender experts. Its aim is to demonstrate how we can harness the creative power of sex and gender analysis for innovation and discovery. Gender analysis adds a valuable dimension to research and can take it in new directions. It generates valuable insights and outcomes for women and men.

The project develops practical tools for scientists and engineers, enabling them to include sex and gender analysis into their basic and applied research work. Our aim is to produce excellence in science, health and medicine and engineering research, policy and practice. We also generate case studies to show concretely how sex and gender analysis leads to innovation. The idea is to get researchers thinking about how gender impacts their work. Many of them may have never thought about this. We want to promote gender thinking, or at least an awareness of the impact of unconscious gender bias on the policies, decisions and activities of institutions and businesses. Again, the aim is to help identify needs and to develop practical solutions that work for everyone.

Why is a gender perspective important for innovation?

In science and engineering hidden gender bias has existed for centuries. In many cases the male body is considered the norm and is the primary object of study. There are so many technologies that have been designed exclusively around men. Even cars are designed around a specific male norm, with women (and smaller men) typically analyzed as an afterthought or viewed as a deviation from that norm. But this can result in harmful outcomes. The conventional seat belt, for example, does not fit pregnant women properly and poses a major safety concern for millions of them. A woman wearing a seatbelt who is carrying a 20-week-old fetus and is involved in a car crash runs a high risk of losing her baby. Motor vehicle accidents are the leading cause of fetal death related to maternal trauma. I have been talking about this for some years, and just recently was invited to discuss the issue at the Stanford Automotive Research Center and was delighted to meet someone from a major car company who is interested in fixing the problem.

It is very rewarding when you present people with a problem that they may never have thought about and

Gender in a nutshell

Gender is all about what it means to be a man and what it means to be a woman or a gender-diverse person. It explores how men and women experience life differently, not because of biology but because of the social and cultural meanings developed around each. For decades, feminist research has underlined the need to evaluate the influence of gender in order to effectively tackle development challenges and promote inclusive development – and with some success. Today, gender equality is one of the 17 United Nations Sustainable Development Goals and is increasingly accepted as an important and necessary objective.





Photo: iStock.com/y© piranka

In science and engineering hidden gender bias can result in harmful outcomes. For example, the conventional car seat belt does not fit pregnant women properly and poses major safety concerns for them. Motor vehicle accidents are the leading cause of fetal death related to maternal trauma.

they can fix it. This is how the Gendered Innovations project is helping to make a real difference to people's lives.

The seatbelt example is just one illustration of why we need to rethink standards and reference models. If we don't pay attention to humans of different shapes and sizes when designing products and technologies, we run the risk of causing unintended harm. If researchers and engineers broaden their vision and take both men and women as the norm, there is every chance they will expand creativity in science and technology, make it work for everyone, and bring safety, well-being and satisfaction to all.

How does including a gender analysis affect outcomes?

Doing research wrong costs lives and money and we miss opportunities for progress. This is particularly evident in the health field. Between 1997 and 2000, 10 drugs were withdrawn from the United States market because of life-threatening effects. Eight of them were found to put women's health at greater risk than men's health. Drug development is a long and costly process. It takes years and costs billions of dollars, and when drugs fail, as these did, they can cause human suffering and death. If medical researchers don't factor gender into the equation, they risk killing patients.

But doing research right adds value and can save lives and money. A study of the United States Women's Health Initiative Hormone Therapy Trial, for example, found

that the trial saved lives, adding 145,000 quality-adjusted lives, and that for every dollar spent in the trial, USD 140 were returned.

Similarly, in business an awareness of the role sex and gender play can create significant new market opportunities and boost profits. A company that doesn't think about gender risks losing customers.

Apple's recent experience with its HealthKit app for iPhones illustrates this. When the company launched the app they claimed it could track all kinds of biometric data, pulse, blood pressure and so on. They were confident it would be a hit. But unfortunately, the developers failed to factor sex and gender into their work – the app did not track the female menstrual cycle. They swiftly lost half of their customers. Poor uptake drove Apple to fix and relaunch it. But at what cost?

On the other hand, the videogame producer, EA, has taken sex and gender on board and has developed software that tracks every move a player makes so they can capture male and female preferences and craft games in line with them. On the strength of these data, they were the first to introduce a range of women's soccer games, sales for which have gone wild.

Do you think a sex and gendered analysis in innovation will make for a more inclusive society?

Yes. Our research shows that the more women authors are involved in a medical paper, the greater the level of sex and gender analysis. I think it is also true that the more sex and gender analysis there is, the more women will get involved in knowledge creation. And that

By analyzing sex and gender throughout the engineering innovation process, researchers are looking beyond stereotypes to understand the complex patterns of young women's and men's video gaming preferences. Challenging gender stereotypes may enhance diversity in video and online games and the industry itself.



Photo: iStock.com/© Minerva Studio

Photo: iStock.com/wildpixel



The assumption that osteoporosis is primarily a disease of postmenopausal women has shaped its screening, practice, diagnosis and treatment and resulted in the underdiagnosis of osteoporosis in men. One-third of all osteoporosis-related hip fractures in Europe and the United States are suffered by men.

is a good thing. After all, women make up around half of the global population and have huge potential, albeit largely untapped, to contribute to human knowledge. Our research suggests that the more widely sex and gender analysis is adopted, the more people who previously were left out are brought in.

Why do policymakers, researchers and entrepreneurs need to take Gendered Innovation seriously?

Gendered Innovation leads to equality and sustainability – people don't throw away the things that work for them – and ultimately serves the public interest. It is an opportunity to improve scientific research and improve understanding of the impact of diseases on men and women, and to ensure that scientific research and technical breakthroughs serve all people equally. It also presents interesting market opportunities. Today, women have much more political clout and purchasing power and are increasingly demanding the technologies and the products that work for them.

Why do you think it has taken so long for researchers and practitioners to buy into the idea of including gender analysis in their work?

For hundreds of years universities were closed to women, but slowly women became students and eventually professors. Now, we have lots of women who are senior professors and we also have many more women holding senior positions in government and business. Cultural change takes time, and needs the right resources and the right political climate. It has taken too long, but now things are changing quickly and there is no turning back because people's eyes are opening.

To achieve gender equality, is it enough simply to encourage girls to take up STEM (science, technology, engineering and mathematics) subjects?

No, encouraging STEM alone is not enough. Interestingly, Silicon Valley companies like Facebook and Google now recognize they need much more than STEM specialists

and are beginning to hire more social scientists and humanists. They realize their success hinges on a deep understanding of society and culture. The prospect of STEM linking up with the humanities and social sciences is very exciting. It will allow engineers, for example, to design many more products that work for everyone.

What else needs to be done?

Gender equality raises two important issues: the need to reduce gender bias against women and to integrate sex and gender analysis into all areas of science, technology and commerce. Gendered Innovations is an attempt to fix the gender gaps in knowledge creation. But of course a lot still needs to be done to fix the numbers of women participating in these fields and the unconscious gender biases embedded in many institutions.

Many organizations are working to remove structural barriers to gender equality. Governments are catalyzing institutional change through programs such as the United States National Science Foundation's ADVANCE Program and the European Commission's Women and Gender in Research programs. Academia is also working to remove gender bias in its hiring and promotion practices, and in the private sector many companies are actively working to improve representation of women in upper management.

But organizations need to be transformed also from the top. Leaders need to actively support gender equality and reward those who advance it. They need to make resources available, set goals and make people aware of how their institution is bringing in those who previously were not represented.

Where do you see Gendered Innovation in the next five to 10 years?

My sense is it will be widely adopted. The European Commission is embracing it, as are the United States National Institutes of Health, the Swiss National Science Foundation and many others. And 10 years from now, I hope we will put ourselves out of business because sex and gender analysis will have become an integral part of the way research and development is done.

Understanding gender and sex-related differences in colorectal cancer risk may improve diagnosis and provide better prevention and treatment protocols for men and women.

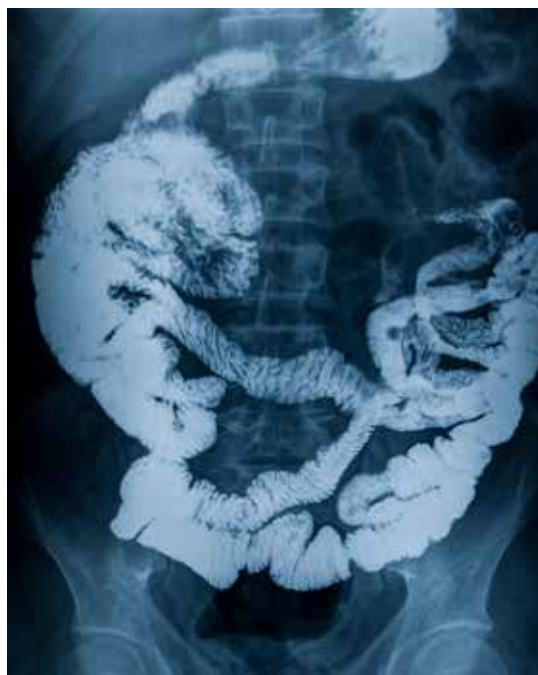

Protecting traditional cultural expressions – some questions for lawmakers

Peter Jaszi, Professor of Law Emeritus,
American University Law School,
Washington, D.C.

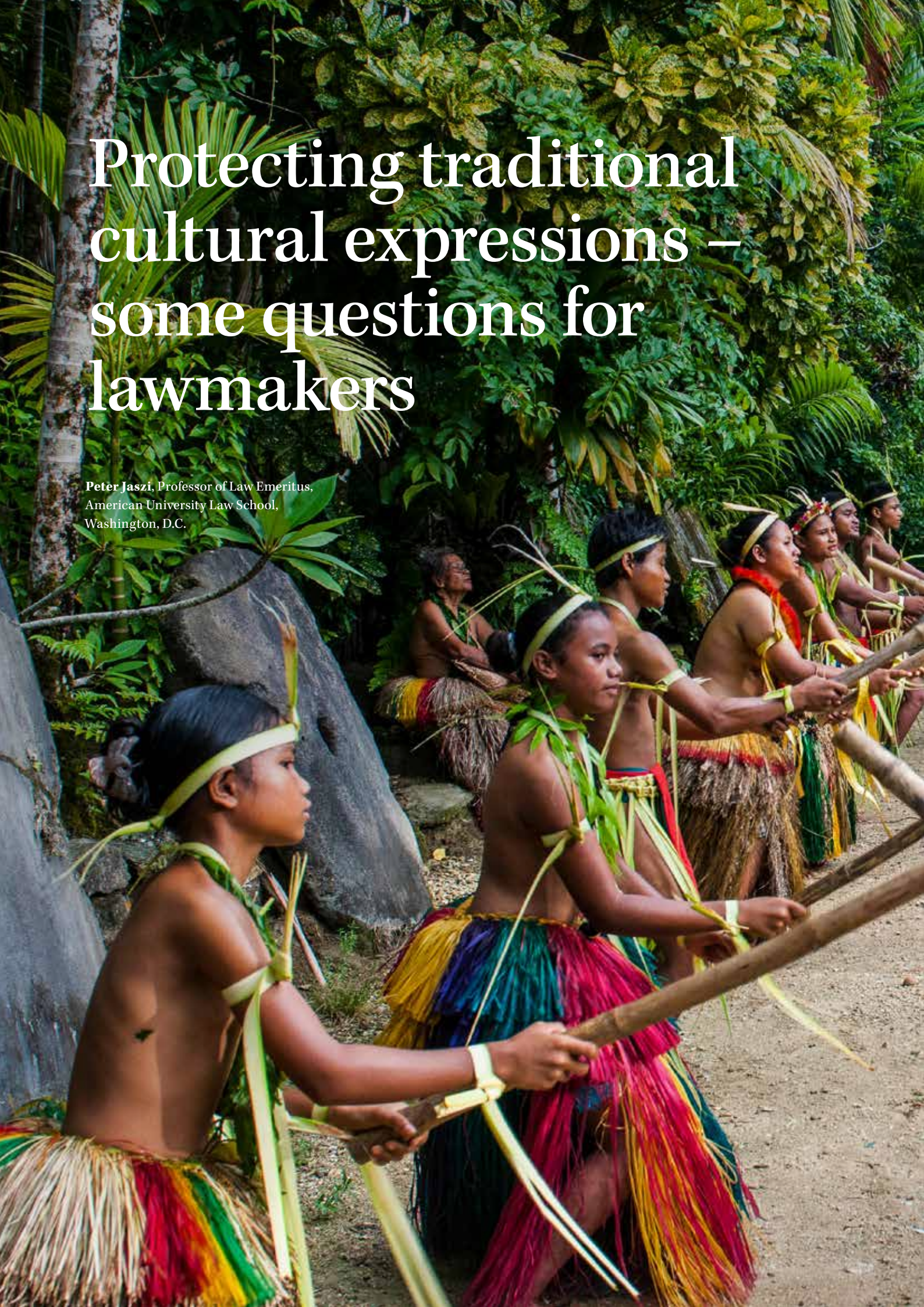



Photo: imageBROKER/Alamy Stock Photo

As international lawmakers grapple with the choices involved in shaping any new international legal regime to protect traditional cultural expressions, the time is ripe to consider "gaps" in the law that may - or may not - need to be addressed.

Experts have been discussing whether and how to protect traditional cultural expressions, or the “old arts”, since the 1950s. But the work of WIPO’s Intergovernmental Committee on Intellectual Property and Genetic Resources, Traditional Knowledge and Folklore is fueling renewed scrutiny of the topic.

As international lawmakers grapple with the choices involved in shaping any new international legal regime to protect traditional cultural expressions, it is timely to carefully consider the “gaps” in the law that may – or may not – need to be addressed, and to reflect on whether existing international copyright laws can support, albeit partially, recognition of traditional cultural expressions.

Before going further, there are two points to bear in mind. The first is that not every identifiable gap in the law needs to be filled. As an example, 19th-century champions of expansive copyright believed that term limitations were a defect in the system that would be remedied by introducing a principle of perpetual protection. Since then, however, Western copyright experts have generally embraced the value of term limits (albeit very generous ones) as a way of assuring a public domain and maintaining balance in the system.

Second, only a multilateral solution can adequately address the specific problems facing the protection of traditional cultural expressions, many of which occur in the global information economy. International IP law assures recognition of rights across the national boundaries of states that sign up to it. It also assures some degree of harmonization among national laws by establishing mandatory minimum standards for national legislation.

SPOTTING THE GAPS

The absence of an international agreement on the protection of traditional cultural expressions is a major structural gap in international law. Some commentators attribute this to the fact that existing IP laws have been constructed around a paradigm that is selectively blind to the scientific and artistic contributions of many of the world’s cultures and established in forums where those most directly affected are not represented. They argue that systematically treating the cultural productions of some communities as naturally occurring raw materials for use by others risks putting a brake on human progress.

There are also gaps at a more functional level, in that there are some things the law does not accomplish – and arguably should. The difficulty in addressing these gaps was driven home to me some years ago on a field trip in Samosir Island in North Sumatra, Indonesia. Together with my fellow researchers, I was invited by chance to a traditional funeral celebrating the life of a local matriarch. It was a joyous event involving dancing couples and a group of young local musicians performing traditional music on local string and drum instruments and an electronic keyboard. The keyboard player told us he loved the old music, but enjoyed tweaking it to reflect Western popular musical influences. He also revealed that the prohibitive cost of hiring a large group of musicians with traditional instruments made using the electronic keyboard an economic necessity. Through this kind of hybridization (and streamlining), he explained, the old music continued to live in the community.

That conversation took us back to a formal interview we had conducted earlier with community leaders elsewhere on the island who had expressed concern about the “misuse” of the musical tradition through the inclusion of Western instruments in local ensembles. Some villages had even banned such performances, and others only stopped short because there was no clear legal basis for doing so.

These diverging perspectives prompted us to question whether the lack of a legal mechanism to regulate the way traditional cultural expressions are transmitted across generations is actually a flaw. Should communities’ freedom of choice about how to adapt old cultural practices to new circumstances be preserved instead? This is a hard, value-laden choice and underlines the fact that not all gaps need filling.

Reaching conclusions about what to leave unregulated often reveals the most profound differences in values and aspirations. Nonetheless, there is a broad perception that gaps exist in at least three functional areas: attribution, control and remuneration.

When it comes to attribution, the people associated with traditional cultural expressions, including the states in which they reside, aspire to legal guarantees that when traditional cultural expressions are disseminated, their sources are fully and appropriately acknowledged. At present, no such assurances exist for traditional cultural expressions as a whole.

Similarly, there are concerns about the need to control the use of traditional cultural expressions, especially those regarded as “secret”, or intended by custom to circulate only within limited groups.

And with respect to remuneration, there is today a widely shared view that traditional cultural expressions are often exploited far from their places of origin, and that a fair international regime would include a mechanism to prevent (or redress) such “misappropriation”.

ARE EXISTING IP REGIMES PART OF THE SOLUTION?

While any new proposal will certainly be judged by how successfully these functional gaps are addressed, the discourse around the protection of traditional cultural expressions tends to concentrate on whether existing regimes of protection adequately cover the specific provisions required to meet the aspirations of indigenous groups. From this viewpoint, how far are existing copyright laws part of the solution? Can the problem be solved by simply tweaking the Berne Convention to bring traditional cultural expressions within the scope of international copyright law? Back in 1971,



Photo: WIPO/Emmanuel Berrod



Photo: ephotocorp / Alamy Stock Photo

While a contemporary variant of a cultural tradition fits comfortably within the grid of copyright law, and may be protected as a “derivative work”, traditional cultural expressions as a whole do not.

Photo: Jeremy Richards / Alamy Stock Photo

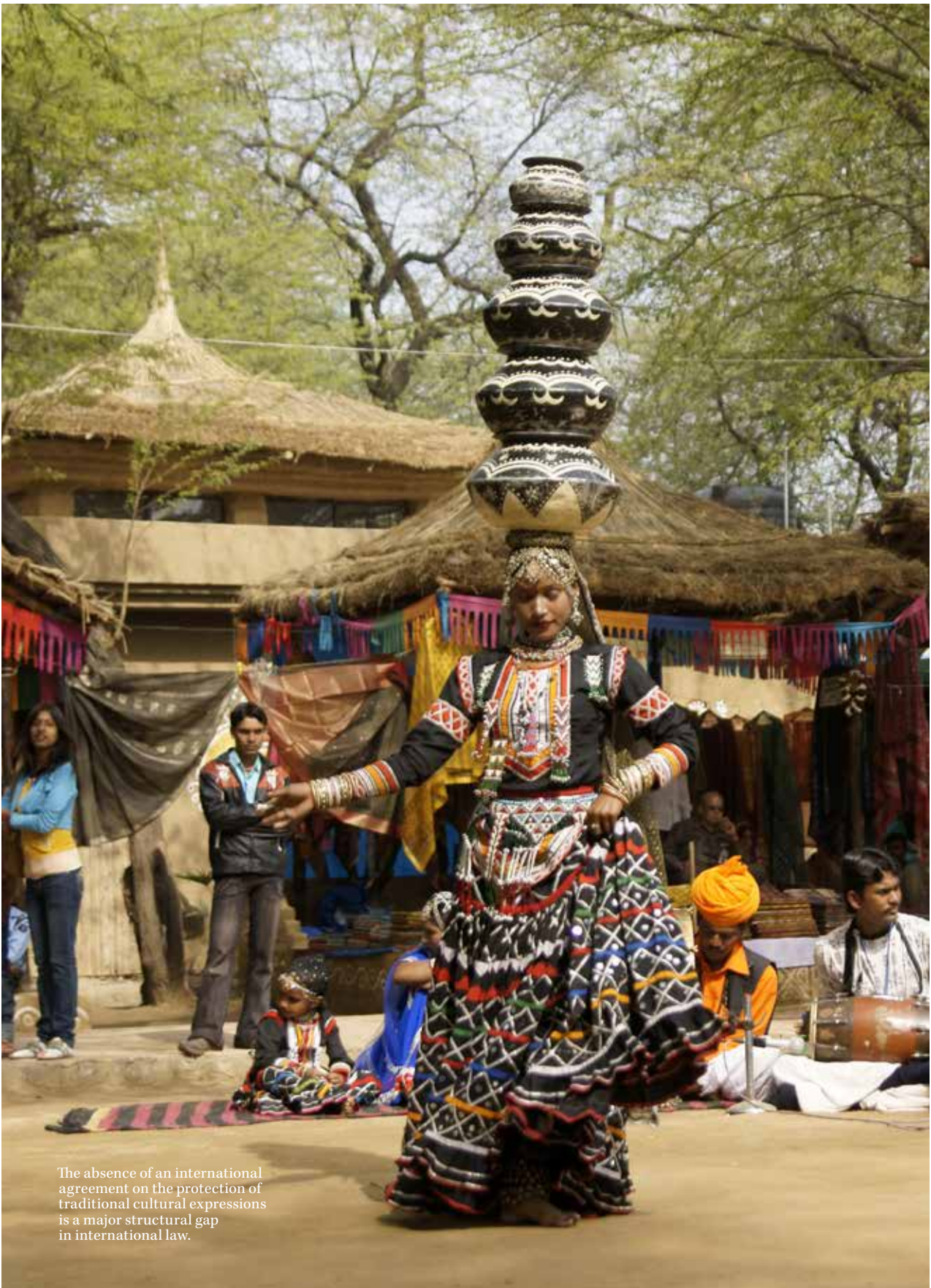

The absence of an international agreement on the protection of traditional cultural expressions is a major structural gap in international law.

lawmakers sought to do this by introducing Article 15.4 into the Berne Convention. The article outlines arrangements for certain unpublished works of unknown authorship (see box), but because it is optional little has changed. Most countries have not enacted it. Moreover, protection for such works is limited to at least 50 years, and only once the work is “lawfully made available to the public.” It also makes no explicit mention of the role of communities: rights on behalf of the author are exercised by “a competent authority.” Its scope is further limited by Article 7.3 of the Convention, under which countries are not required to protect anonymous works when it is reasonable to presume the author has been dead for 50 years.

But is there a case for simply repairing these defects? After all, bringing traditional cultural expressions into the fold of copyright law would offer remedies to address misuse of traditional cultural expressions, including injunctive relief and damages in most countries. It would also trigger the mandatory application of basic moral and economic rights in at least 170 countries.

WHAT COPYRIGHT LAW DOES AND DOES NOT DO

On the downside, such an approach fails to effectively protect traditional cultural expressions on a number of counts.

Copyright has evolved around the idea of “authorship” to favor claims of rights in ascertainably original and relatively recent products of imagination. Over time, copyright law has been remarkably flexible in defining “authorship”. For example, an object qualifying for protection may originate from an individual (e.g., a novel) or a group (e.g., a film). Common law jurisdictions have even fictionalized the idea by introducing the “work for hire” doctrine, whereby an employer is considered the author of the merged contributions of employees. But there are limits – and instances beyond the ingenuity of copyright lawyers – in which not even a fictional person can comfortably be assigned responsibility for a cultural tradition, the value of which has been produced collectively (rather than collaboratively) by a group.

The Berne Convention (Article 15.4)

Article 15.4 of the Berne Convention states that:

“(a) In the case of unpublished works where the identity of the author is unknown, but where there is every ground to presume that he is a national of a country of the Union, it shall be a matter for legislation in that country to designate the competent authority which shall represent the author and shall be entitled to protect and enforce his rights in the countries of the Union.

(b) Countries of the Union which make such designation under the terms of this provision shall notify the Director General by means of a written declaration giving full information concerning the authority thus designated. The Director General shall at once communicate this declaration to all other countries of the Union.”



Photo: Jeremy Richards / Alamy Stock Photo

Policymakers involved in international discussions on the protection of traditional cultural expressions are also considering whether partial protection for traditional cultural products is possible under existing copyright law.

Moreover, traditional cultural expressions have often been understood as lacking individualization, originality, recentness and fixity. Many individual traditional cultural expressions may satisfy some or all of these requirements, but others do not. Take, for example, a 300-year-old musical tradition originating from a specific community that continues to practice it today. Let's assume it consists of a group of simple melodies played on specific instruments with a body of stylistic rules governing how it should be performed. Such a cultural tradition fails comprehensively to fit the grid of copyright. It lacks even hypothetical individual "authors"; it is not "original", having been faithfully transmitted across generations; and it lacks the required definite form – unless a work has a stable form capable of more or less identical repetition, it is not copyrightable.

IS PARTIAL PROTECTION OF TRADITIONAL CULTURAL EXPRESSIONS POSSIBLE UNDER COPYRIGHT LAW?

From the above, it is clear that any attempt to shoehorn traditional cultural expressions into copyright law is simply a non-starter. But is there potential for partial protection of them under copyright law?

In relation to concerns about the unauthorized recording and exploitation of traditional cultural performances, a legal regime for the protection of musical performers is already in place in most countries, albeit originally conceived with the commercial music and broadcasting industries in mind. Nothing would seem to prevent these laws being used to protect traditional cultural expressions.

Today, the traditional cultural expressions most at risk are contemporary variants of ancient musical, choreographic, graphic and other traditions. These works are likely to be the most attractive and accessible to would-be exploiters. Contemporary copyright law actively protects new versions of preexisting works – the modern retelling of a Greek myth, for example – as a "derivative work". The resulting protection is more than sufficient to tackle most cases of piracy, and in most jurisdictions the individual interpreter's moral right of attribution is protected.

But while a contemporary variant of a cultural tradition fits comfortably within the grid of copyright law, traditional cultural expressions as a whole do not, and in various ways. First, copyright law fails to protect secret or sacred knowledge, which typically maintains its original form across generations. Second, it does not protect the attribution interests of the communities that give rise to contemporary interpretations of traditional cultural expressions. Third, the protection afforded to contemporary variants of traditional cultural expressions is limited in scope: it is applicable to reproductions, performances and displays of relatively close imitations, but not to all new work "inspired" or "influenced" by them. Fourth, as with all copyrightable subject matter, variants of contemporary traditional cultural expressions would ultimately enter the public domain. And perhaps most significantly, the rights conferred by copyright are subject to statutory exceptions (e.g., for education, museums and archives), the scope of which varies – sometimes significantly – from country to country.

Photo: Ryan M. Bolton / Alamy Stock Photo



Today, the traditional cultural expressions most at risk are contemporary variants of ancient musical, choreographic, graphic and other traditions.

QUESTIONS FOR LAWMAKERS

Should lawmakers consider leaving some gaps unfilled when designing a new legal regime to protect traditional cultural expressions? Might this support the communities that sustain traditional cultural expressions? And can they learn from the values expressed in copyright law?

Take, for example, term limitations and the concept of a public domain. Are these ideas simply an unwanted intellectual legacy, or do they have universal appeal? While not an easy question, there is something to be said for “sunsetting” the legal protection of all knowledge. One argument for allowing protected traditional cultural expressions to enter the public domain is that – as is the case for moral rights in protected works in many countries – attribution rights in traditional cultural expressions could be made effectively perpetual. This

question deserves additional, clear-eyed consideration. Similarly, might traditional cultural expressions qualify as one of the protected and affirmative carve-outs for certain privileged uses that feature in all existing IP systems?

One further point of fundamental inquiry relates to the familiar pronouncements about how IP should serve the spread of knowledge among all peoples. Are these simply fig leaves for injustice, or are they valid despite the self-serving ways which they often are deployed? And if they are valid, can they be accommodated through a model of protection based on concepts of compensation rather than exclusivity?

These are some of the unavoidable questions that lawmakers will need to address when deciding how porous or “gappy” a system of protections for traditional cultural expressions should be.

Copyright exceptions: an archivist's perspective

By **Jean Dryden**, International Council of Archives, Paris, France



Photo: Simon Reddy / Alamy Stock Photo

Archives have enduring value to human society, offering insights that help shape the future.

In a world where we are constantly in search of the new, archives – information recorded about the everyday activities of governments, businesses, organizations and individuals – may, at first sight, seem rather outdated and unappealing. But many of these records have enduring value both to those who create them and to human society. They offer a window on the past, and insights that help shape the future.

An organization's archives may consist of correspondence, reports, financial and legal documents, recordings of public speeches, publicity materials; an individual's archives may include letters, diaries, photograph albums, scrapbooks or home movies, for example.

The Universal Declaration of Archives, adopted by UNESCO in November 2011, clearly expresses the public interest role that archives fulfill:

“Archives are a unique and irreplaceable heritage passed from one generation to another ... They are authoritative

sources of information underpinning accountable and transparent administrative actions. They play an essential role in the development of societies by safeguarding and contributing to individual and community memory. Open access to archives enriches our knowledge of human society, promotes democracy, protects citizens' rights and enhances the quality of life.”

Archives can also refer to an organization whose mission is to preserve the documentary heritage of a particular institution. For example, the United Nations, the United Arab Emirates, the Government of Malawi, the City of Montréal, Cambridge University and the Coca-Cola Company all operate archives to preserve archival materials that fall within their respective acquisition mandates.

ARCHIVISTS AND OTHER PROFESSIONS

The professionals who assess, collect, organize, preserve and provide access to archival holdings are archivists. They are sometimes confused with other related

professionals, such as librarians and museum curators. While all three professions collect, preserve and make materials accessible for research, in general they differ significantly in the material with which they work. Materials in archival collections are unique and often irreplaceable, whereas libraries can usually replace worn-out or lost books and other published materials in their holdings. Museum curators collect, study and interpret mostly three-dimensional objects, while the archivist works primarily with paper, film, audio and digital records.

WHY DO ARCHIVES NEED COPYRIGHT EXCEPTIONS?

Copyright law aims to achieve a balance between the interests of creators, so they receive a just reward for their works, and the public interest in terms of ensuring the public has access to such works. In this way, copyright law supports further creation as well as the growth of knowledge and culture and its diffusion.

Archives play an essential role in serving the public interest by preserving and making such works available to the public. Archives, however, are subject to the same copyright law as commercial publishers and the entertainment industry although archival holdings were not (for the most part) created for commercial purposes or for dissemination to the public, and thus are largely, but not exclusively, unpublished.

The unpublished nature of the majority of archival holdings has several consequences. Rights holders are unlikely to be interested in monetizing their intellectual property; in fact, many are unaware that they are copyright owners. Archival holdings also contain a high proportion of orphan works, that is, works for which the copyright owners cannot be identified or located. In general, this is because copyright owners of these materials have no vested interest in being readily traceable to grant permission for use or to derive income from their creations. Moreover, for archival material, there are no effective licensing models. Thus, in order to be able to serve their users, particularly in a global society, archives are dependent on internationally recognized exceptions and limitations to copyright law.

WHAT COPYRIGHT EXCEPTIONS DO ARCHIVES NEED?

Archives require limitations to copyright law in the following areas:

Preservation: One of the primary roles of an archive is to preserve the materials in its care. Preservation often requires copying. For example, where originals are too fragile to be handled archives create reference copies that researchers must use in order to safeguard the originals. Given the speed of technological change, the need is even more urgent for digital holdings. To ensure that digital holdings remain accessible, it is standard practice for archives to copy works from proprietary formats to open standard formats, or to copy records to newer versions of software. Archives therefore require an exception to copyright law to ensure that they are able to continue to serve the public interest while operating within the bounds of copyright law.

Reproduction for research: The other primary role of an archive is to make its holdings available for study and research. Because archival material is unique and irreplaceable, archives do not lend their holdings, but rather, provide users with copies. The Internet provides exciting opportunities for archives to make their holdings available to a wider research audience by digitizing them and making them available online. As such, archives require a reasonable exception to be confident that such activities do not infringe.

Cross-border uses: The territorial nature of copyright is incompatible with today's global landscape. Frequently, researchers need to consult records in other countries (as a result of migration, trade and so on) for academic or personal research or in pursuit of legal rights relating to nationality, identity and property. For example, when the Government of France released the archives of its counterintelligence service in Indochina in the 1950s, many researchers from Asia, not just from France, were interested in investigating those records. Similarly, the archive of photography collected from 26 African countries by the School of African Heritage in Benin is only accessible to users if copies of the archive material are made or if users actually travel to the archive.

Some nations have exceptions and limitations to copyright that allow archives to perform their public role without fear of infringing rights. However, exceptions and limitations to copyright law tend to vary from one country to another, and often do not provide for the export of archival materials in the first place. And in instances where such export is possible, archives seeking to share their materials with clients in other countries still face a number of challenges. For example, when copies are sent to a country where the copyright law differs or where the copy does not meet national requirements. How can the archivist or the user act lawfully? Either archives cannot provide cross-border services or copies will be provided regardless of the law. A solution need not be complex. It could simply involve all countries recognizing the legitimacy of a copy lawfully made by an archive in another country.

Orphan works: Most archival materials are the accumulated records of governments, companies, charities, families and individuals. For example, the papers of a cabinet minister may contain thousands of letters and emails from citizens, bureaucrats and other officials. If an archive wished to digitize these records and make them available online, it would involve a labor-intensive and costly process of identifying and tracking down thousands of rights holders, many of whom are not known or cannot be located. Archives need an exception that makes it possible to make orphan works legally available without a costly (and in many cases fruitless) search.

Limited liability: Because they fear legal liability, archivists are extremely cautious when selecting what they make available online. They choose only holdings in which they own the copyright or in which the copyright has expired. Consequently, their online offerings are a small fraction of their rich holdings, and may not best serve users' interests. As a consequence, the information service to which the public is entitled is greatly diminished. This is yet another reason why archives require reasonable exceptions that limit liability for their legitimate actions. Such a limit on liability would enhance the range of online offerings and enable archivists to better serve society.

Technological protection measures: The WIPO Internet treaties (the WIPO Copyright Treaty and the WIPO Performances and Phonograms Treaty) require signatories to amend their copyright legislation to prohibit the circumvention of technological protection measures (TPMs). Statutory limitations and exceptions should not be nullified by TPMs. Archives should be allowed to acquire and apply tools to remove such measures, so they can fulfil their public interest mission. For example, archives typically acquire materials after they are no longer needed for business purposes. The passwords, encryption keys and so on may have been lost or forgotten, and the archives may need to circumvent the TPMs to examine the material to see if they want to acquire it or access it for the purposes of preservation, cataloguing and making available to users. A mandatory provision that provides a general exception to the circumvention prohibition would ensure recognition of the legitimacy of non-infringing acts performed by archives. To do otherwise undermines copyright's fundamental balance.



Photo: David Bagnall / Alamy Stock Photo

Archives play an essential public interest role by preserving and making their holdings available to the public. They are, however, subject to the same copyright law as commercial publishers and the entertainment industry although most archival holdings were not created for commercial purposes or for dissemination to the public. Archives depend on internationally recognized exceptions and limitations to copyright law to be able to serve their users.

Contractual override of exceptions: Exceptions and limitations that are fundamental to the archival mission may be overridden by contractual agreements. For example, some archives use private sector vendors to provide cloud storage for their digital holdings. If the vendor is located in another jurisdiction the cloud storage provider may fail to comply with the copyright laws of the repository's jurisdiction. Contractual overrides completely nullify the purpose of the exceptions, and tip the copyright balance entirely in favor of rights holders, making it more difficult for archives to fulfil their public service mission.

ARCHIVES CALL FOR AN INTERNATIONAL TREATY

Copyright owners may consider that the list of exceptions and limitations that archives are calling for is nothing more than a blank check. But that could not be further from the truth. In the first place, the professional principles that undergird archival work require archives to take reasonable steps to protect the interests of the owners of rights in the works in their collections. Second, the exceptions outlined would be subject to reasonable

conditions, such as, for example, that the activity is for non-commercial purposes, and would not affect any established market for the works in question. Archivists need these exceptions to be able to do their job.

Limitations and Exceptions for Libraries and Archives has been a separate item on the agenda of WIPO's Standing Committee on Copyright and Related Rights since November 2011.

While many member states strongly support a binding international treaty, others maintain that an exchange of national practices is sufficient. Exceptions are fundamental to maintaining the balanced structure of copyright law, and the consistent application of exceptions is necessary to enable effective archival services that fulfil the social objectives of copyright law in a globalized world. Archivists and their allies will continue to advocate for a treaty that requires signatories to establish minimum exceptions and limitations to allow archives, libraries and museums to serve their users, including by providing cross-border access to their holdings in a globalized world.

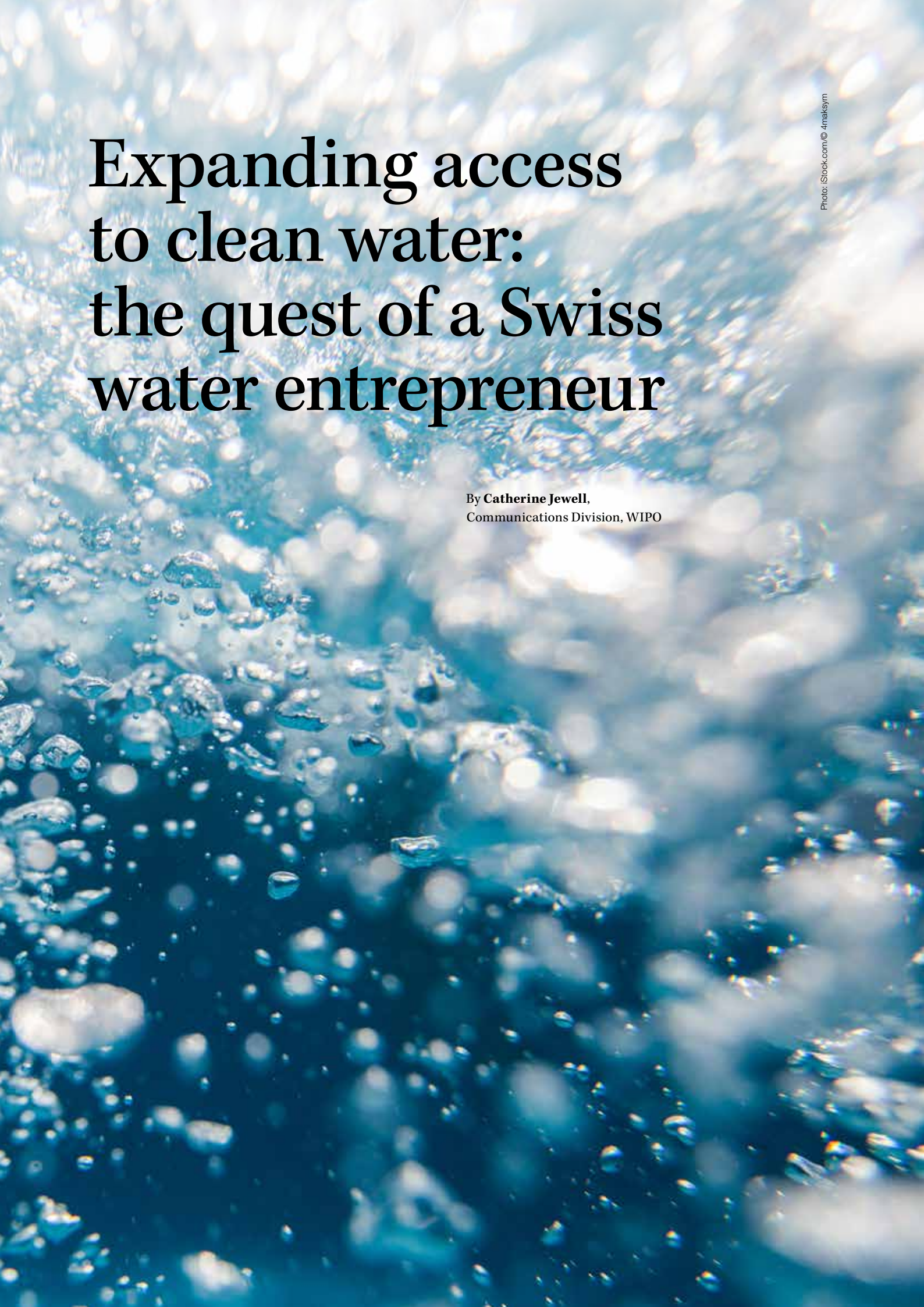

Expanding access to clean water: the quest of a Swiss water entrepreneur

By **Catherine Jewell**,
Communications Division, WIPO

Renaud de Watteville is a Swiss water entrepreneur with a vision – to provide the world’s poorest communities with clean drinking water at an affordable price and, at the same time, create jobs and support community development. This is in fact the shared goal of the two entities he established. The first, Swiss Fresh Water, is a private company based in Switzerland. It focuses on developing Internet-connected, high-quality, low-cost water treatment systems that produce clean water to WHO standards. And the second, Access to Water, is a non-profit foundation that supports the deployment of water treatment solutions and job creation in communities in Senegal and other developing countries.

Today, one in 10 people in the world lack access to safe drinking water. The consequences for the health and livelihoods of those living in affected communities are far reaching.

WIPO Magazine recently met with Mr. de Watteville to find out more about how Swiss Fresh Water and the Access to Water Foundation are tackling this global challenge and how innovation and intellectual property are supporting their work.

How did you get into the water business?

In the course of my travels I came across many poor communities in developing countries where people had no choice but to drink dirty or brackish water. I saw the negative impact this was having on their lives. So when the opportunity arose, I began working on a water treatment system that provides people in these communities with access to a clean and safe water supply. That’s how I came to set up Swiss Fresh Water and Access to Water.

What is the relationship between Swiss Fresh Water and the Access to Water Foundation?

Swiss Fresh Water is a social enterprise that develops and produces low-cost water treatment units supported by an online service platform. We believe that a technology without maintenance has no future. Access to Water is a non-profit organization that was created with a grant from Swiss Fresh Water in 2012. It runs programs that set up water kiosks that use Swiss Fresh Water machines so communities get access to clean water. In this way, we create opportunities for employment and community development. Today, Swiss Fresh Water and Access to Water are strictly independent of each other.

Swiss Fresh Water and Access to Water believe everyone should have access to safe water at an affordable and acceptable price. Our aim is to improve living conditions on site, generate income opportunities, enable children to go to school (they no longer have



Photo: WIPO/Cathy Jewell

Renaud de Watteville, founder of Swiss Fresh Water and Access to Water, at his workshop near Lausanne, Switzerland. His mission is to provide the world’s poorest communities with clean drinking water at affordable prices and to create jobs for local people.

Kiosk owner Mbeye, who sells water and takes care of the two machines below. So far, Access to Water has installed 133 machines in Senegal, all of which are fully operational.



Photo: Access to Water Foundation

to spend time fetching water for their families), and support social cohesion, local economic development thanks to job creation, safeguard the environment and slow rural-urban migration. That is why we focus on producing water on site.

Swiss Fresh Water's mission is to make low-cost, high-quality machines that are easy to install, efficient, user-friendly, affordable, and supported with good service via the Internet.

Six years ago we launched our first pilot project in Senegal. We quickly realized we had to separate our for-profit and our non-profit activities. Swiss Fresh Water had to remain for-profit to secure investors and attract the finance needed for the business to expand. So we brought our non-profit activities under the Access to Water umbrella, to enable us to secure development funds and donations to fund programs to install water kiosks in communities that lacked access to safe water. By the end of 2016, Swiss Fresh Water had sold 210 water treatment units, of which 120 were deployed in Senegal through Access to Water's programs.

How does the Access to Water business model work?

Access to Water targets poor communities with no access to clean water. We offer a simple and economically sustainable business model. Access to Water purchases water treatment machines, solar panels, water tanks and a motorbike for water delivery and installs the equipment in kiosks which are run by local entrepreneurs. They sell the purified water from the machine to local customers and the proceeds of these sales finance the maintenance of the machine. It's a model where everyone across the value chain wins.

Anyone interested in setting up a kiosk applies to SENOP, the operational arm of Access to Water in Senegal, which employs six local technicians. Access to Water owns the machines and deploys them for a small fee to kiosk owners. Kiosks vary in size. We have small, medium, large and extra-large ones.

All our machines are controlled and monitored remotely. We operate a pre-paid system whereby kiosk owners buy 20,000 liters of water up front. The water is treated by reverse osmosis and is certified to meet WHO standards. Once we receive proof of payment via SMS, we start the machine and the kiosk starts selling water to customers at around EUR 0.014 per liter. This is much cheaper than other bottled water. We advertise the price widely to ensure kiosks don't overcharge. If they do, we simply stop the machine remotely. The kiosks bottle and deliver water, recycle containers, and often serve as a local store.

Fifty percent of sales proceeds go to the kiosk owner so they can employ people and pay them good salaries, and the other



Photo: Access to Water Foundation

Kiosk with solar-powered water filter machine in Diamniadio, Senegal. Access to Water, a non-profit foundation, purchases water treatment machines, solar panels, water tanks and a motorbike for water delivery and installs the equipment in kiosks run by local entrepreneurs. All the water treatment machines are controlled and monitored remotely via the Internet.

50 percent goes to the Foundation to amortize machine and maintenance costs and repay loans. Any surplus goes toward purchasing and deploying new machines.

For non-profit programs, a machine costs around EUR 8,000 and annual maintenance costs come in at around EUR 2,000. All machines are cleaned and serviced every four to six weeks. So far, Access to Water has installed 133 machines in Senegal and they are all fully operational. We are very proud of that.

An extra-large kiosk can produce up to 4,000 liters of clean water per day and will amortize machine and maintenance costs in around four years. But a small kiosk producing 300 liters a day will never manage to break even. That is why Access to Water's non-profit governance structure is so important. It allows us to spread maintenance costs across kiosks of all sizes, and in particular to support small kiosks – which make up

around 30 percent of all kiosks – in small rural villages, which are most affected by rural migration.

We constantly adapt and tweak our business model. We believe a bottom-up approach is essential. If it isn't bottom-up it won't work. It is really important that people take ownership of a project. And that is what we are seeing with the kiosks in Senegal today.

What sort of impact is your work having?

Since we began operating around six years ago, we have provided more than 280,000 people with access to safe drinking water and created more than 480 sustainable jobs. We are very proud of that. The impact on people's lives is immediate. As soon as they start drinking water from our machines, their ailments clear up. They no longer have diarrhea, headaches, hypertension, or skin problems. Every day we are improving people's lives.

How exactly does the machine work?

Our machines treat all types of water very efficiently. Brackish, dirty water goes through a series of filtration processes and is drinkable as soon as it leaves the machine. First, leaves and other large matter are removed. Then bacteria, viruses and parasites are filtered out. After that, the water passes through activated charcoal and undergoes a process of reverse osmosis to remove any chemicals and heavy metals (fluorine, mercury, arsenic, etc.). Forty percent of the processed liquid becomes safe drinking water and the remainder returns to the ground. We simply extract potable water from ground water to prevent people from getting ill.

Our machines are compact, easy to transport and work on or off-grid (they are solar-power adaptable). The water they produce is filtered to 0.0001 microns by reverse osmosis. That's very clean!

The machine has various sensors and an in-built computer and SIM card which tell us exactly how it is performing and give us a detailed operating history. We simply go online and zoom in to see what is happening with any one of them.

We are already working on our next machine which will be even more efficient and user-friendly. All our machines are fully tested and calibrated at our workshop near Lausanne, Switzerland, before shipping.

What role does innovation and intellectual property play in your work?

Swiss Fresh Water and Access to Water both have a strong innovation mindset. We are constantly looking for new ways to improve our business model. For example, we are developing a card payment system for kiosk owners and have recently started working with the IKEA Foundation to facilitate the setting-up of water kiosks in Better Shelters.

And on the technology side, we are always fine-tuning our machines and looking for ways to make them more robust and efficient so they operate effectively in the harshest environments and to reduce maintenance costs. Whenever we have a good idea we file a patent application. WIPO's Patent Cooperation Treaty offers an inexpensive way to secure protection for up to 30 months and to assess the patentability of our technology in different countries. It gives us time to decide what we want to do with the technology. It also stops others from filing a claim for the same thing and gives us the freedom to use it as we like. And it shows our investors we are capable of developing patentable solutions. It strengthens our credibility.

We also own various trademarks, for example for Swiss Fresh Water and Diam'O, the brand name used by kiosk owners in Senegal. As Swiss Fresh Water expands into wealthier markets, I think intellectual property will be an increasingly important part of our business strategy.

About the Patent Cooperation Treaty (PCT)

WIPO's Patent Cooperation Treaty assists applicants in seeking patent protection internationally for their inventions, helps patent Offices with their patent granting decisions, and facilitates public access to a wealth of technical information relating to those inventions. By filing one international patent application under the PCT, applicants can simultaneously seek protection for an invention in more than 150 countries. Find out more about the PCT at: www.wipo.int/pct/en/.



How did you come up with the Diam’O brand name?

The first machine we installed was in the village of Diamniadio, which means “doors of peace” in the local language. So when we were looking for a brand name, we thought of Diam’o, which sounds like “water of peace”. People thought it was a good idea. It’s neutral and evokes something positive.

Why did you join WIPO GREEN?

Participation in WIPO GREEN plugs us into a very large network of potential business partners and is another way for us to boost our credibility. Many people think that solutions for developing countries are bound to

fail. But that is not necessarily the case. Our success in Senegal is living proof of that.

What are some of the main challenges Access to Water is facing?

We face multiple challenges. It is not always easy to find the right people for the job; people who share our vision and have the energy to make things happen. This is a big challenge. Finance is another big hurdle. Our projects are funded by donations and loans but securing these takes a lot of work. We also have to ensure we have in place a solid structure that enables us to scale up our operations. And of course, we always need to keep an eye on the future. Thankfully, there is a lot of interest in what we are doing, so the prospects for the future are looking bright.



Photo: iStock.com © Bartosz Hadyniak

About WIPO Green

WIPO Green is an interactive marketplace that contributes to green technology innovation and transfer by bringing together a wide range of technologies and players in the green technology innovation value chain. It connects owners of new technologies with individuals or companies looking to commercialize, license or otherwise access or distribute a green technology. Learn more about WIPO Green at: www3.wipo.int/wipogreen/en/.

Trademarks and China's business reform agenda

By **Mr. Zhang Mao**, Minister of the State Administration for Industry & Commerce, People's Republic of China



Photo: Lou Linwei / Alamy Stock Photo

For the past 15 years, China has topped global rankings for trademark applications and registrations. Tencent is China's top brand, valued at USD 106.2 billion according to the BRANDZ™ Top 100 Most Valuable Chinese 2017 report.

As the global economy shows signs of recovery and digital technologies continue to transform industrial and business landscapes across the world, innovation – and the intellectual property (IP) rights that protect it – remain key drivers of economic development.

Within this context, trademarks play a crucial role, particularly when it comes to bringing new products to market and supporting business growth. Trademarks enable customers to identify the products and services a company offers and help the company distinguish its goods and services from those of its competitors.

Trademarks are one of a number of IP rights companies can use to protect their innovative assets, strengthen their competitive position, expand their market share and improve their bottom line. Steadily increasing awareness of the value of trademarks and brands among Chinese entrepreneurs is enabling them to boost demand for and realize the market value of their innovative products.

The Chinese Government sets great store on trademarks and brands. Since the implementation of its 2009 Trademark and Brand Strategy, China has achieved remarkable results, meeting and surpassing established targets at every turn.

Reform of China's business environment is continuing apace, generating important gains in many areas. New enterprises are forming at an unprecedented rate, and growing awareness of the value of trademarks among businesses and the general public is fueling record-breaking use of the trademark system.

For the past 15 years, China has topped global rankings for trademark applications and registrations. In 2016, the number of trademark applications and registrations rose to 3,691,000, representing an annual increase of 28.35 percent.

All indicators suggest this upward trend will continue. In the first six months of 2017, the State Administration for Industry & Commerce (SAIC) received 2,276,000 trademark applications and processed 1,211,000 registrations, with 13,452,000 registered marks currently in force, including 3,625 registered geographical indications, collective trademarks and certification marks.

Moreover, in the same period, the number of trademarks owned per 10,000 market players rose to 1,448 from 1,074 in 2011 – a growth rate of 34.8 percent. In China today, there is one registered trademark for every 6.9 market players.

The rapid development of China's trademark and branding landscape is the result of sustained reform of the country's business environment made possible by extensive and shared efforts of the Government, enterprises and society as a whole. A number of factors account for this remarkable transformation.

NEW BUSINESS GROWTH BOOSTS USE OF TRADEMARKS

The Government's drive to reform China's business landscape took off in 2014 with the implementation of a series of measures, including lowering barriers to market access and boosting investment in startups. The aim was to inject new dynamism into the Chinese market and promote business growth.

Since then, unprecedented numbers of new businesses have sprung up, further boosting the uptake and use of the trademark system by Chinese firms.

By the end of 2016, the number of market players rose to 87,054,000, with 5,528,000 new enterprises registered

in 2016 alone. This is equivalent to an average of 15,100 new enterprises registered every day, up from 12,000 per day in 2015 and more than double the number of daily registrations in the pre-reform period (6,900).

The number of newly registered individual businesses also rose dramatically to some 58,000,000 by the end of 2016, with more than 1,749,000 specialized agricultural cooperatives registered in the same year. This growth momentum is set to continue for some years to come.

The emergence of large numbers of new market players brings immense vitality to Chinese entrepreneurship and innovation and, with it, the need for an effective trademark registration system.

CHINA'S TRADEMARK REGISTRATION SERVICES IMPROVE

A major overhaul of China's trademark registration system has been ongoing since 2014, when the SAIC began working to develop and provide users with a more streamlined, efficient, user-friendly and cost-effective trademark registration system.

To encourage uptake and use of the system, the Government has steadily lowered trademark registration costs. These have gone down from RMB 1,000 in 2013 to RMB 300 in 2017.

Reforms of the trademark examination process, including the introduction of a law to shorten the period of examination to under nine months and the launch of an online trademark registration service, have also helped to boost the system's use. In the first six months of 2017, online trademark applications accounted for over 87 percent of all applications filed, representing a 10 percent increase on figures for the same period in 2016.

EVIDENCE OF BRAND VALUE BOOSTS TRADEMARK USE

Growing evidence of the brand value that can be created by registering trademarks is also driving uptake of the system in China. Awareness of the rising value of Chinese brands is growing in all sectors of society and the economy. In 2012, just one Chinese brand appeared in global consulting firm Millward Brown's list of the world's top 100 brands. In 2017, 13 Chinese companies are featured.

An enterprise's trademarks and brands encompass its commercial reputation, underpin its economic value, and have an important bearing on the productivity and performance of a business and the way it manages its assets.

SAIC is actively supporting local companies in their attempts to enhance business value through pledge financing. This enables enterprises to secure loans against their trademark assets. In this way, the value of their brands is factored into the enterprise's capital worth.

In 2016, SAIC handled 1,410 trademark pledge registration applications, helping enterprises raise RMB 64.99 billion in financing. As at June 30, 2017, 410 pledge registrations have been processed, enabling enterprises to raise RMB 14.94 billion. These types of measures are enhancing both awareness of and the value of trademarks and brands across the business community.

BUILDING A COMPETITIVE BUSINESS ENVIRONMENT

China's remarkable achievements in the area of trademark protection are fostering a competitive environment for brand development and economic growth.

Administrations for industry and commerce (AICs) across the country are committed to strengthening compliance with trademark law through a series of special measures with a view to ensuring effective market order. AICs, law enforcement authorities, customs and courts covering both administrative and judicial areas are working together to crack down on trademark infringements and counterfeiting. Greater awareness among enterprises of the importance of trademark and brand protection is also a positive force in terms of tackling such infringing uses, as is an increased awareness among the public of the need to respect IP rights in general.

CHINESE BRANDS GO GLOBAL

Rapid growth of the Chinese economy and the internationalization of Chinese brands have also boosted China's use of WIPO's Madrid System for the International Registration of Trademarks. According to WIPO, in 2016 for the first time China ranked among the top five countries using the Madrid System. In that year, Chinese applicants submitted 3,200 international trademark applications under the System – a year-on-year increase of 68.6 percent.

Also in 2016, foreign applicants sought to protect some 22,314 trademarks in China through the Madrid System. For the 12th consecutive year, China was the most designated country by foreign trademark applicants under the Madrid system.

CHINA CELEBRATES ITS BRANDS

Brands underpin the competitiveness of an enterprise and a country. Recognizing their economic importance, the State Council is implementing its trademark and brand strategy within the period of *The 13th Five-year Market Supervision Plan (2016-2020)*. In this context, as of 2017 "Chinese Brand Day" will be celebrated annually on May 10. The aim here is to further deepen understanding of the importance of registering trademarks and building brands, and to support of the Government's continued reform of the country's business landscape. It will also enable us to take advantage of every opportunity to raise



Photo: Courtesy of SAIC

A major overhaul of China's trademark registration system has been ongoing since 2014 with a view to offering users a more streamlined, efficient, user-friendly and cost-effective service.

awareness of the importance of trademarks and brands, for example through the implementation of the country's national IP and innovation-driven development strategies and the "Belt and Road Initiative". Guided by this market-oriented reform, SAIC will continue to improve its trademark registration services in support of business growth and the emergence of a broad range of Chinese trademarks that are recognized by consumers around the world.

AICs have an important role to play in this endeavor, for example through active implementation of trademark and brand strategies to ensure trademarks continue to drive China's economic growth and transformation. Our common aim is to better serve "mass entrepreneurship and innovation" in support of advancing and upgrading the demand and supply structure of China's economy.

SAIC will continue to ensure effective regulation of the trademark system and to deliver a better public service by

supporting the development a cost-effective, user-friendly and efficient trademark registration system in China. We will reinforce existing procedures for the protection of registered trademarks by developing and implementing innovative and effective supervision mechanisms and processes, including for credit monitoring. And we will ensure greater coherence between Government authorities, enterprises and the market, encouraging the business initiative of enterprises and cooperatives to build an integrated national brand development system. We will also support efforts to build local brands in line with the philosophies of "innovation, coordination, eco-friendliness, opening-up and sharing".

And we will make every effort to enhance the international competitiveness of Chinese enterprises and their brands, supporting and guiding them as they "go global" and encouraging them to strengthen the competitiveness of Chinese brands in international markets.



Intellectual property and development: the ASEAN story



Photo: iStock.com © OlegCarPhoto

In August 2017, the Association of Southeast Asian Nations (ASEAN) celebrated its 50th anniversary. Intellectual property has been at the heart of efforts to transform the region into a highly innovative and competitive bloc.

By **Ambassador Evan P. Garcia**,
Permanent Representative of
the Philippines* to the United
Nations and Other International
Organizations in Geneva.

A group of five countries with a common dream of peace: this was how the Association of Southeast Asian Nations, or ASEAN, began 50 years ago on August 8, 1967, in Bangkok, Thailand. This historic milestone in regional relations formalized the rather loose community of countries, originally composed of Indonesia, Malaysia, the Philippines, Singapore and Thailand, which until then had been exploring different region-building options.

From the outset, member states of ASEAN have been diverse in language and culture, strengthened nevertheless by different but shared histories and a common desire to improve the lives of their people. Back in 1967, the world was riding on the promise of a relatively young United Nations forged from the tragedy of the Second World War. And while the conflicts of a bipolar world played out, casting a cloud of uncertainty across the globe, ASEAN began carving a path of collaboration to secure its future. At that time, the combined GDP of ASEAN was just USD 23.7 billion, political institutions were still evolving and infrastructure was underdeveloped. The birth of ASEAN was indeed a defining moment, born of the courage and foresight of the region's leaders.

The membership of Brunei Darussalam in 1984, Viet Nam in 1995, the Lao People's Democratic Republic and Myanmar in 1997 and Cambodia in 1999 completed the organization and further consolidated its institutions. Economic integration, anchored by extensive dialogue and cooperation in the political-security and socio-cultural fields, continued to galvanize relations within ASEAN and between its member states and other major economies in the region.

Such integration was further strengthened with the establishment of the ASEAN Economic Community in 2015. The Community had by then grown to a population of 629 million with a combined GDP of some USD 2.4 trillion, making it the sixth largest economy in the world and the third largest in Asia. In 2015, ASEAN trade also rose to USD 2.3 trillion, the fourth largest share in the world after China, the United States and Germany. Meanwhile, foreign direct investment totaled USD 121 billion, accounting for 7 percent of global inflows.

This remarkable growth did not come about by chance. Rather, it was the result of the systematic implementation of comprehensive measures in support of economic integration, including harmonized procedures on customs, immigration and trade. It was also thanks to a strategy that clearly acknowledged the varying levels of development of member countries and that actively sought to create opportunities for less-developed members to catch up. At a time when the world is increasingly toying with protectionism, ASEAN continues to shine a bright light on economic integration, inclusion and openness.

*The Philippines is the current
chair of ASEAN.



Photo: ASEAN Secretariat

Leaders of the Association of Southeast Asian Nations (ASEAN) link arms in the iconic ASEAN way during the 30th ASEAN Summit Opening Ceremony at the Philippine International Convention Center on April 29. (Left to right) Malaysian Prime Minister Dato, Sri Mohd Najib bin Tun Abdul Razak; State Counsellor for Myanmar Aung San Suu Kyi; Thai Prime Minister General Prayut Chan-o-cha; Vietnam Prime Minister Nguyen Xuan Phuc; Philippine President Rodrigo Roa Duterte; Singaporean Prime Minister Lee Hsien Loong; Brunei Sultan Haji Hassanal Bolkiah; Cambodian Prime Minister Hun Sen; Indonesian President Joko Widodo; and Lao Prime Minister Thongloun Sisoulith.

INTELLECTUAL PROPERTY FOR DEVELOPMENT

ASEAN has identified intellectual property (IP) as a fundamental element of the ASEAN Economic Community Blueprint 2025, which sets out specific steps to be taken by member countries to transform ASEAN into a highly innovative and competitive region.

ASEAN recognizes that IP provides a good starting point for member states to encourage innovation as part of a comprehensive package of national and regional economic incentives. Countries like Malaysia, the Philippines, Singapore and Viet Nam have launched IP awards that lend prestige their best innovators and innovative practices. By protecting original ideas and works, IP laws and regulations allow businesses, entrepreneurs, inventors, artists and creators to flourish in a fair environment that enhances public access to a competitive market of

goods and services. Moreover, the World Intellectual Property Organization (WIPO) presented the WIPO Global Leaders Award to His Majesty King Bhumibol Adulyadej on January 14, 2009 in recognition of his dedication to using intellectual property to help Thailand develop: more than 4,000 Royal Projects utilizing IP have benefited not just Thailand but other countries as well.

The development of a balanced and well-founded IP strategy – one that frames policies and programs in support of national development priorities – is a significant step toward ensuring that IP works for everyone. In this regard, countries like Indonesia, the Lao People's Democratic Republic, Myanmar, the Philippines and Viet Nam have ongoing cooperation with WIPO to enhance their respective national IP strategies. This is a long-term process that requires the active support of all stakeholders, including the private sector, government

and the individual purveyors of original ideas themselves. From technology that converts mango waste into commercially viable products to a resurgence of ASEAN motifs in global designs, IP provides the incentives required to ensure a constant flow of original creative works that ultimately contribute to social well-being and the public good.

ASEAN countries use IP to protect their national patrimony. In Cambodia, Indonesia, Thailand and Viet Nam, this means the creation of a range of geographical indications. Thailand, for instance, takes advantage of the IP protection available for wines, spirits, rice and silk not only to safeguard the quality of those products, but also to reinforce its national identity in the global marketplace. In addition to certification and collective marks, Viet Nam is developing geographical indications to control the quality and promote the visibility of its products, and to ultimately improve the lives of its farmers and harness its agricultural export potential. Likewise, Cambodian geographical



Photos: GEMS, Philippines

ASEAN countries use intellectual property to protect their national patrimony and ensure a constant flow of original creative works that contribute to social well-being and the public good. Technology developed by researchers in the Philippines to transform mango waste into marketable products now underpins a business employing 60 people.

indications, which include Kampot pepper and palm sugar, are gaining worldwide recognition. In the Philippines, national authorities are using IP to support the rights of indigenous peoples and local communities through a regulation that mandates the establishment of a registry of indigenous knowledge systems and practices and requires the disclosure of traditional knowledge used in patent applications. With diverse ethnic cultures, customs, value systems and genetic resources, Indonesia is strengthening its legal landscape for traditional knowledge and traditional cultural expressions and is leading international discussions in this regard.

ASEAN countries are developing IP as a platform for institution-building. The establishment of Technology and Innovation Support Centers (TISCs) in some countries is helping to complete the journey from product conception to commercialization. Building hubs for interaction between and among inventors, academia and the private sector is crucial in fostering robust linkages between research and development and the market. To this end, Brunei Darussalam is rolling out a series of intensive public awareness campaigns to educate the general public about IP and promote greater use of IP systems and services. Singapore, in its capacity as an International Searching Authority and International Preliminary Examining Authority under WIPO's Patent Cooperation Treaty, is also raising the bar for the quality of patents and patent applications across the region. Meanwhile, the Philippines facilitates dispute resolution through its alternative dispute resolution services and has achieved a high settlement rate. The Intellectual Property Office of the Philippines recently successfully mediated an application for special compulsory licensing involving public health, a case that ended with a win-win solution for both the government and the pharmaceutical company involved.

INSTITUTIONAL SUPPORT

The diverse political, economic and socio-cultural landscape of ASEAN means that close, purposeful and meaningful collaboration is necessary to fully harvest the region's potential and bridge any gaps within and among countries. This is where the ASEAN Working Group on Intellectual Property Cooperation plays a key role. Composed of the heads of the IP offices of ASEAN member states, the Working Group meets regularly to review and enhance IP regulatory frameworks with a view to spurring innovation-led growth and helping the region move higher up the technology ladder.

Global institutional engagement is crucial in strengthening the web of national programs and the region's IP strategy. For ASEAN and WIPO, formal relations began in 1993 with the establishment of a regular consultation mechanism. WIPO subsequently supported the crafting of the ASEAN Intellectual Property Strategic Plan for 2016-2025. The Plan lists four broad goals: strengthening offices and building infrastructure; building regional platforms; expanding ecosystems; and enhancing regional mechanisms to promote asset creation and commercialization, particularly for geographical indications and traditional knowledge.

The Strategic Plan is playing an important role in bolstering the region's innovation and competitiveness. In general, over the past decade ASEAN member states have recorded upward performances in the Global Innovation Index. Singapore, in particular, is recognized as the seventh most innovative country in the world, while Viet Nam has registered one of the biggest leaps by any country in the Index in recent years.

With its economic optimism and prospects buoyed by a population where more than 50 percent are under 30 years of age, ASEAN provides a fertile environment in which ideas can be created, nurtured and made accessible for the public good. Its welcoming borders help germinate ideas fit for an international audience. In 2016 alone, 108.8 million tourists visited the region, of whom 42.4 percent were intra-ASEAN, indicating robust people-to-people exchange.

EVOLVING NARRATIVE

Over the past 50 years, ASEAN has consistently transformed itself from an economic backwater to a major player with influence in global politics and economy – this is the story of ASEAN. The 50th ASEAN Foreign Ministers' Meeting, which the Philippines hosted on August 5, 2017 as current ASEAN Chair, continued this resolve and reaffirmed the region's tradition of constructive engagement

and consensus building. Yet the narrative continues to evolve. Even as the region's economic dynamism brings about immense opportunities, development gaps persist within and among its member states. Recent global trends add new challenges that must be addressed. Effective and coherent institutional and policy support needs to be sustained to steer broad, synergistic growth in intellectual property, innovation and related sectors.

In the ASEAN context, the business of IP goes beyond protection. It is about ensuring that the benefits of innovation and competition are enjoyed by everyone, from the largest megacities to the smallest villages. It is about spurring innovation, protecting national patrimony, building institutions, and protecting and preserving the knowledge and traditions of indigenous peoples. It is about increasing the quality of life.

It is, ultimately, about the people.

The ASEAN Secretariat building in Jakarta, Indonesia. ASEAN countries have identified intellectual property (IP) as a fundamental element of the ASEAN Economic Community Blueprint 2025.



Twelve ways to manage global patent costs

By **Anthony de Andrade**, President and CEO, and **Venkaresh Viswanath**, Senior Analyst, Quantify IP

In the face of scathing budget cuts, there is tremendous pressure on the finance and intellectual property (IP) teams of innovative companies to obtain broad and strong patents year after year. That is why it is so important for them to develop effective strategies to manage and minimize the costs of patenting their groundbreaking technologies throughout a patent's 20-year lifecycle. Here are some ways they can do so.

1. DO YOUR HOMEWORK BEFORE DECIDING WHERE TO FILE

A first essential step is to develop a smart patent filing strategy. This involves assessing the market potential and growth of a technology over the life of a patent; the location of manufacturing centers; competitors and their filing strategy; the nature of the invention; and the enforceability of patents.

The nature of your invention will inevitably determine your target markets but when identifying them, it is really important to consider how different jurisdictions define what may or may not be patented. For instance, in certain jurisdictions, including Canada, Europe (via the European Patent Office (EPO)) and India, inventions relating to methods of treatment or diagnosis cannot be patented. The patentability of software, business methods, genetic material, and stem cells also varies across jurisdictions and should be factored into filing strategy decisions.

2. FEES VARY IN RELATION TO THE NUMBER OF CLAIMS

Filing fees can also vary across jurisdictions. The number of claims in an application can affect the fees payable when filing a patent application, requesting its examination and maintaining its validity. For instance, in the United States, the filing fee goes up when an application contains more than 20 claims and more than three independent claims. An "independent claim" defines the unique features of the disclosed invention and can form the basis for one or more "dependent claims", which pertain to a particular embodiment of the invention and further refine an independent claim. In the Russian Federation, the fee for requesting an examination is set according to the total number of independent claims in an application. And in Japan and the Republic of Korea, both the fees

for requesting an examination and the renewal fees are determined by the total number of claims. This is also the case for renewal fees in Indonesia (total number of claims) and Viet Nam (number of independent claims).

When filing applications in Japan and the Republic of Korea, it may therefore be worth consolidating multiple claims to create a single claim that is dependent from multiple claims, deleting those that have limited value and a high probability of refusal.

Also, law firms often charge for handling any additional claims and these costs can exceed official filing fees.

3. GO GREEN – OPT FOR E-FILING SERVICES

In an attempt to improve their carbon footprint, cut costs and improve efficiency, many IP offices, including those of Australia, Brazil, India, Japan, Malaysia, the Republic of Korea and the EPO, offer e-filing services at preferential rates. For example, it costs 46,000 Korean Won to file a patent application (unlimited pages) electronically with the KIPO, while the filing fee for a paper application containing up to 20 pages is 66,000 Won (with 1,000 Won payable for each additional page).

4. CONTAIN YOUR TRANSLATION COSTS

Translation costs are incurred in three circumstances: when filing or prosecuting a patent application in jurisdictions where English is not an official language; at the time of grant of a European patent; and when validating a granted European patent in certain EPO member states (i.e. those that have not signed the London Agreement, which seeks to reduce the costs of translating European Patents).

Translation costs can be hefty. The estimated costs of translating an application into Chinese, Japanese, Korean and Russian lie between USD 3,000 and USD 6,500 (approximately 75 to 80 percent of the total filing costs). Moreover, a significant proportion of the costs of validating a granted European patent arise from the need for translations.

Translation costs can be managed or reduced by focusing on English language jurisdictions, or blocs such as Latin America that share a common official language. Translation costs can be further reduced through effective patent drafting and by removing any redundant text from patent specifications.

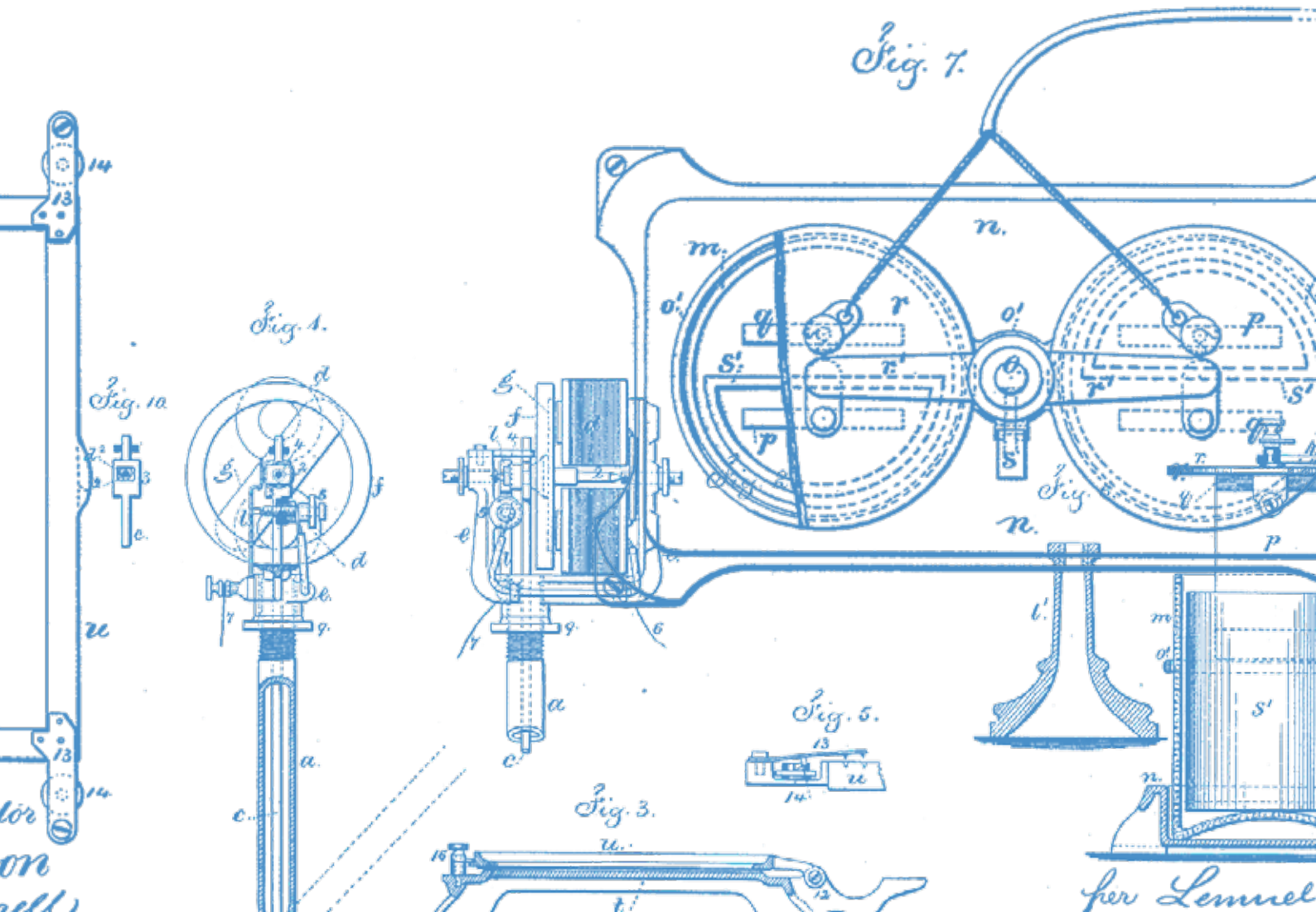

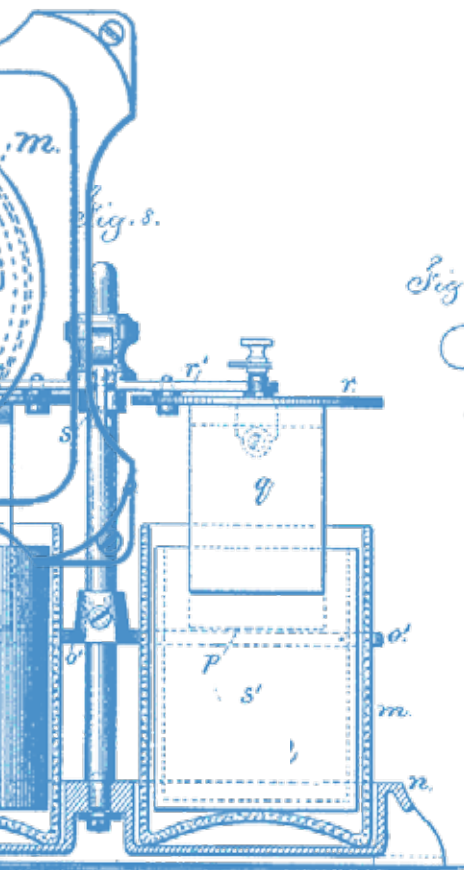
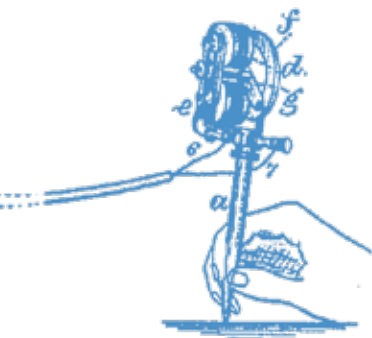

5. USE WIPO'S PATENT COOPERATION TREATY TO DEFER NATIONAL FILING COSTS

By filing an international application with an appropriate Receiving Office under WIPO's Patent Cooperation Treaty (PCT), an applicant can defer the costs of filing national applications in more than 150 countries by around 30 months from the date of first filing.

The PCT offers various strategic advantages. These include more time to study the commercial viability of the invention in target markets, and invaluable feedback on the potential patentability of an invention thanks to a mandatory International Search Report (ISR) and an optional International Preliminary Examination Report (IPER), which make it easier for applicants to make informed decisions about their patenting strategy. Search and/or examination fees may also be reduced in some circumstances at the time of national phase entry (i.e. when a national office examines the substance of an application). Costs can also be reduced by opting for expedited examination through the PCT-Patent Prosecution Highway (PCT-PPH).

6. CHOOSE SEARCH AND EXAMINATION AUTHORITIES WISELY

Filing an application under the PCT involves selecting an International Searching Authority (ISA) to undertake a search of the prior art to determine the novelty and the inventiveness of the technology for which a patent is being sought. These searches give applicants an idea of the patentability of their technology. Twenty-two patent offices operate as ISAs. The ISA that applicants can select depends on the jurisdiction in which they first file their application. For example, an applicant filing a PCT application with the United States Patent and Trademark Office (USPTO) (as PCT Receiving Office) may select the IP offices of Australia, Israel, Japan, the Republic of Korea, the Russian Federation, Singapore, the United States or the EPO as ISA. Each PCT Receiving Office has specified one or more competent ISAs.

In general, it is advisable to select an ISA located where you intend to file a national phase application. If, for example, the aim is to obtain a European patent, then the EPO is best placed to do the search. But ISAs set their own fees which can vary significantly, and some offer discounts. For example, the EPO, among the more pricey ISAs, offers a EUR 190 discount on ISRs drawn up by the patent offices of Australia, China, Japan, the Republic of Korea, the Russian Federation and the United States. Likewise, the Russian

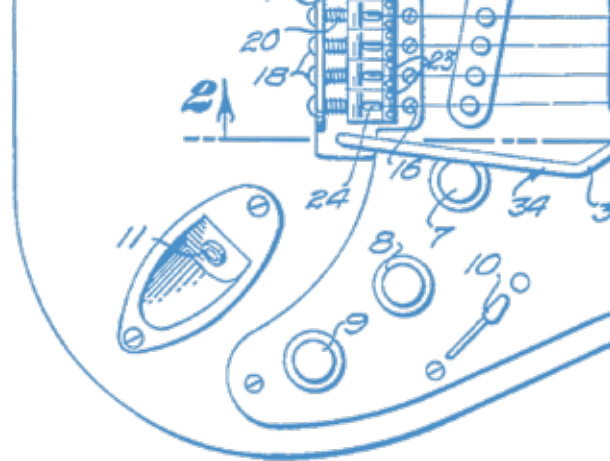

Patent Office offers a 50 percent reduction on the examination fee for the ISRs it produces and a 20 percent reduction for those drawn up by other ISAs. The speed with which the different ISAs produce their reports, and their quality, are other important considerations when selecting an ISA.

7. TAKE ADVANTAGE OF EXPEDITED PROCESSING OPTIONS

Several national patent offices collaborate through what is known as a Patent Prosecution Highway (PPH) to streamline and expedite the processing of patent applications. PPH arrangements effectively allow each of the participating national IP offices to benefit from work already done by another patent office on a given patent application. Examples include the PCT-PPH, the Global PPH (GPPH) covering the IP offices of 22 countries, and the IP5 PPH covering the world's five largest patent offices: the State Intellectual Property Office of the People's Republic of China, the EPO, the Japan Patent Office, the Korean Intellectual Property Office, and the USPTO.

The ASEAN Patent Examination Cooperation (ASPEC) offers another type of work-sharing agreement. It includes the patent offices of Brunei Darussalam, Cambodia, Indonesia, the Lao People's Democratic Republic, Malaysia, Singapore, Thailand, the Philippines and Viet Nam. ASPEC generates search and examination reports in English and offers applicants an opportunity to make substantial savings on translation costs.

8. FILE A REQUEST FOR EXAMINATION WHEN YOU FILE YOUR APPLICATION

Unless additional time is required to test the commercial potential of an invention, it may be advisable to file a request for examination at the same time as filing a patent application. Some law firms do not charge anything extra for this. Such an approach could save time and money in jurisdictions like India, which follow a deferred system of examination (see box) and have not signed up to any PPH agreements.

9. DON'T FORGET THE MODIFIED SUBSTANTIVE EXAMINATION OPTION

Modified substantive examination, where an IP office grants a patent if it corresponds to one granted in another jurisdiction, could lead to substantial savings in prosecution costs. Malaysia, for example, has such a system for patents granted by Australia, the EPO, Japan, the Republic of Korea, the United Kingdom and the United States. In Thailand, the Prime Minister's Office recently authorized the Department of Industrial Property to grant applications when: at least five years have lapsed since the filing date; a request for substantive examination has been filed; a corresponding patent

About deferred patent examination

Some national patent offices offer applicants the possibility of deferring the examination of their patent application for a specified period. This effectively takes the application out of the queue for examination for the period of the deferral, after which it is placed back in the line and will be processed in the usual way. Deferred patent examination effectively extends the pendency of the application. It can be a valuable marketing tool, for example in extending the "patent pending" status of consumer products, and can be useful for companies seeking to defer patent examination fees.

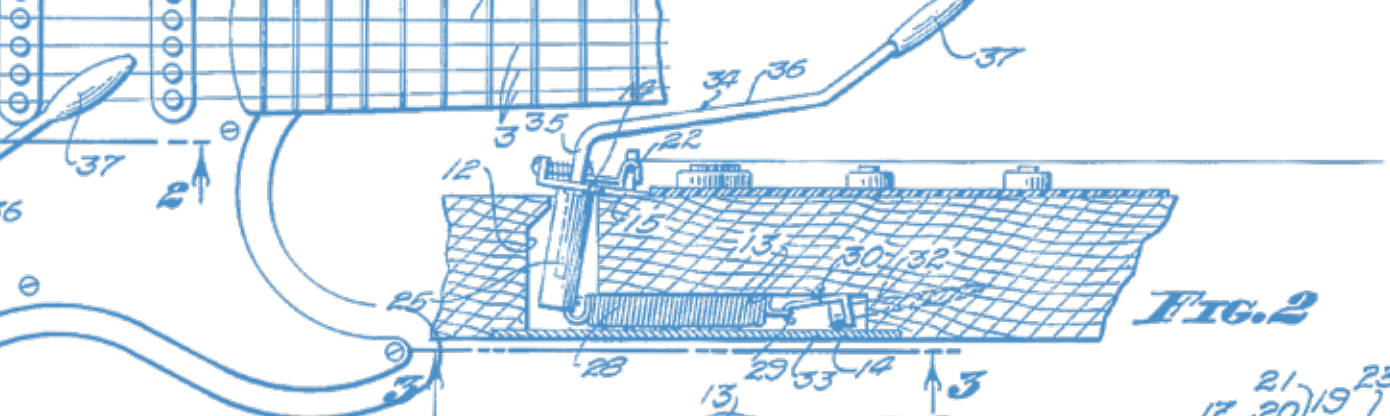

FIG. 2

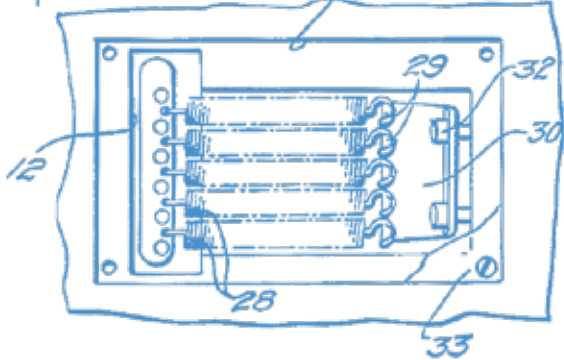

FIG. 3

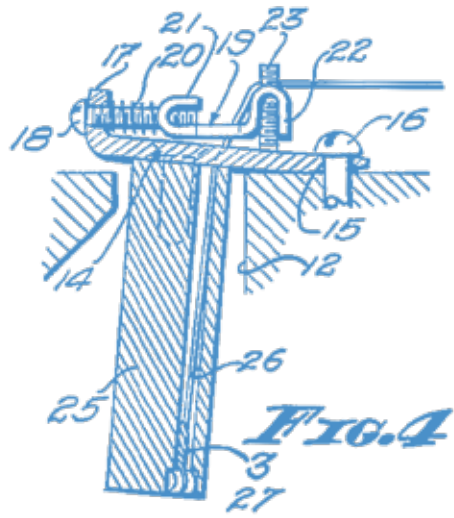

FIG. 4

INVENTOR.
CLARENCE L. FENDER

has been granted in another country; and the claims in the Thai application correspond to those of the granted foreign patent.

Israel also has modified substantive examination for patents granted by Australia, Austria, Canada, Denmark, the EPO, Germany, Japan, Norway, the Russian Federation, Sweden, the United Kingdom and the United States, but retains the discretionary power to reject a request for modified examination.

10. KEEP ANY SUPPORTING DOCUMENTATION IN ORDER

Be sure to gather any supporting documentation, such as assignment deeds and certified priority documents as soon as possible. Delays can be painful and costly.

11. CONSIDER LICENSING RIGHTS TO REDUCE MAINTENANCE FEES

Maintaining a patent can be expensive: maintenance fees account for up to 75 percent of the total estimated costs of a patent across its 20-year lifecycle. However, by declaring their intention to license a patent to a willing third party, applicants can benefit from discounted maintenance fees in around 20 countries, including

Belarus, Brazil, the Czech Republic, Germany, Ireland, Italy, Lithuania, Latvia, , Slovakia, Spain, the Russian Federation and the United Kingdom.

12. BE OPEN TO STRATEGIC ABANDONMENT

Last, but not least, right holders need to continuously monitor the value of their patent and to abandon it when it loses value. This may occur when a protected technology becomes outdated or obsolete or no longer supports a company's business goals. Strategic abandonment can lead to substantial savings in maintenance fees payable throughout the patent's life. These generally increase substantially as the patent ages.

Strategic abandonment is used by companies like Samsung Electronics, Fujifilm, Toshiba, IBM and others to prune their patent portfolios and contain patent maintenance fees.

OVER TO YOU

Obtaining and maintaining a global patent portfolio can put a huge strain on the financial resources of companies. That is why it is so important to carefully develop cost-effective IP strategies that support your business goals. These are some of the ways to do so.

US Supreme Court rewrites the rules on patent exhaustion

By **Emma Barraclough**, Freelance journalist

“When you’re RIGHT, you FIGHT,” reads the website tagline of Impression Products Inc. But the decision by the small family-owned business to fight a patent lawsuit over printer ink cartridges has had an impact far bigger than the company would ever have imagined: the rules on patent exhaustion in the United States have been rewritten, upending the business practices of companies in the repair and spare parts sector and potentially forcing US patent owners to rethink the way that they price their products around the globe.

The dispute involved two companies: Lexmark, a Kentucky-based multinational business that makes and sells imaging equipment; and Impression Products, a West Virginia company whose 25 employees repair printers and resell printer cartridges.

For decades the printer ink industry has sought to defend its lucrative after-sales ink cartridge market, developing a range of technological and commercial barriers to deter competitors from refilling and reselling printer inks. Lexmark utilized both high-tech solutions and financial incentives. It offered customers two pricing options: a full-price ink cartridge that users could dispose of as they wish and a lower-priced version sold through the company’s “Return Program”. These cartridges were fitted with a microchip to prevent reuse, and customers agreed to transfer their empties only to Lexmark.

The legal battle between the two began when Lexmark formally objected to Impression’s business practices: buying up empty Return Program printer cartridges, filling them with new ink, removing their microchip and selling them on.

As the case wound its way through the US courts, judges were asked to consider two questions: had Impression infringed Lexmark’s patents by selling refilled Return Program cartridges in the United States when Lexmark had specifically barred reuse and resale, and had it breached Lexmark’s patent rights by importing printer cartridges into the United States that the company had sold overseas?

At the heart of the questions is the exhaustion doctrine.

The doctrine of patent exhaustion holds that once a patent owner has sold a patented product for the first time, they no longer have control over it: the buyer can use, sell, license, or destroy it as they wish. The *Lexmark* dispute raised questions about the extent to which a patentee can impose restrictions on what a buyer does with a product

A small company in West Virginia built a business on selling refilled printer cartridges. When it was accused of infringing patents, it decided to fight. Its victory at the Supreme Court has reshaped the doctrine of exhaustion and forced businesses to review their business strategies.



Photo: iStock.com/sergeevspb

once they have bought it and enforce those restrictions under patent law. It also sought clarification about the application of the doctrine of exhaustion to goods sold overseas, where US patent law does not apply, which are then imported for sale in the United States.

THE FEDERAL CIRCUIT DECISION

The importance of the issues raised by the case led Federal Circuit judges to decide to hear it *en banc*, citing the need to consider whether its earlier decisions on questions related to patent exhaustion remained sound in the light of subsequent rulings by the Supreme Court, including the *Kirtsaeng* copyright case (see page 44).

In February 2016 a majority of Federal Circuit judges backed Lexmark, concluding that the company's patent rights had not been exhausted by its first sale. The Court held that Lexmark was within its rights to sue Impression for patent infringement on the grounds that a patent owner who sells an item with clear limits on resale or reuse can enforce those restrictions with a patent infringement claim.

On the second question, Federal Circuit judges agreed with Lexmark that its rights had not been exhausted when it sold its products abroad, giving it the green light to sue for infringement when Impression imported its cartridges, refilled them and sold them in the United States without permission.

THE SUPREME COURT WEIGHS IN

The Supreme Court agreed to hear Impression's appeal, prompting more than 30 IP owners, industry associations and academics to file amicus briefs offering their advice to its justices.

The Imaging Supplies Coalition, representing multinational printer companies, urged the Court to uphold the Federal Circuit's decision. It argued that both rights holders and consumers benefit from a rule of patent exhaustion that allows for valid use restrictions, and that national exhaustion supports international economic development by allowing patent owners to set different prices around the globe.

These arguments were also backed by associations representing pharmaceutical and biotech companies – enterprises that place price differentials at the heart of their global pricing strategy and rely on the doctrine of patent exhaustion to police that strategy. BIO and Croplife International, for example, claimed that if the Supreme Court placed any limitation on the doctrine of exhaustion it could enable arbitraging of cheaper products. "Any benefits to US consumers," the brief read, "would likely accrue at the expense of poorer consumers elsewhere."

Associations representing businesses that repair and resell patented products hit back. The Owners' Rights initiative, a coalition that includes eBay and the Association

The role of *Kirtsaeng*

Throughout the dispute loomed *Kirtsaeng v John Wiley & Sons, Inc.* That case, decided by the Supreme Court in 2013, also dealt with exhaustion – this time in the context of copyright law. The dispute required the justices to decide whether a publisher could prevent books bought overseas from being resold in the US using copyright law. A majority came down on the side of *Kirtsaeng*, agreeing that his sale of textbooks bought overseas was protected by the so-called first-sale doctrine.

Lexmark reminded the Court that *Kirtsaeng* dealt with copyright law and did not mention the Patent Act. The printer company urged the justices to keep the two areas of law separate. Impression pressed the Supreme Court to reconcile *Kirtsaeng* with patent law, arguing that its common law determination on the first-sale doctrine applies equally to patent law.

All but one of the justices were convinced by Impression's argument on the question of international patent exhaustion, with a dissenting opinion from Justice Ginsburg. She disagreed with the Court's reliance on *Kirtsaeng* and claimed that it was too difficult to draw an analogy between patents and copyright on questions of international exhaustion because whereas copyright law is harmonized across many countries, patent law is not.

of Service and Computer Dealers International, argued that if the Federal Court decision was to stand, “title to millions of items of personal property will be clouded, a pall will be cast over resale and rental markets, and infringement litigation floodgates will open”.

It was in this legal and policy context that the Supreme Court reached its decision on the two questions before it. Its answer was clear: “patent exhaustion is uniform and automatic.”

It went on: “We conclude that a patentee’s decision to sell a product exhausts all of its patent rights in that item, regardless of any restrictions the patentee purports to impose or the location of the sale... [R]estrictions and location are irrelevant; what matters is the patentee’s decision to make a sale.”

On the question of domestic patent exhaustion, the Court ruled that a patent owner exhausts their rights when they sell a patented product. While Lexmark can use contract law to restrict what a customer does with a product it has purchased, the IP owner cannot bring an action for patent infringement.

On the second question, the Court ruled that an authorized sale outside the United States exhausts all patent rights, just as if the sale had been made in the US. In practice, patent owners will now no longer be able to rely on patent law to help them prevent arbitragers from buying their products cheaply overseas and importing them into the United States to resell them.

CHANGING LANDSCAPE

What does the ruling mean for business? It has been welcomed by companies that want to get a slice of the repair and spare parts market. Patent owners who seek to protect their after-sales markets have seen their options shrink. Now they will need to rely more heavily on contractual terms to limit what customers can do with their purchases. In-house lawyers are likely to be busy over the next few months beefing up provisions in their companies’ end user license agreements. Given the practical difficulties of enforcing such terms, however, many patent owners will ramp up the game of technological catch-up that they play with competitors, placing ever-more sophisticated practical barriers such as digital rights management tools in their way.

But the decision also poses big challenges to the way that companies in other industries, particularly in the pharmaceutical sector, run their businesses. Traditionally, originator drug companies have priced high in the United States and low in developing countries, where political and public relations pressures (as well as price-capping regulations) often encourage them to supply medicines at a cost that local consumers are better able to afford. Now there will be fewer legal blocks in the way of third parties who want to buy their products cheaply overseas and sell them into the United States. Mark Grayson of Phrma, which represents many big US drugs companies, says the organization is still evaluating its next steps in the light of the decision.

So what are the options for patent owners in the sector? One may be for IP owners to press the government to include tougher patent provisions in any trade deals the US negotiates or renegotiates. Another may be to ask legislators to reform US law to give domestic IP owners more power to control what happens to their patented products. Yet another is that some companies may stop selling medicines in certain markets to minimize the risk that arbitragers buy them to resell in the United States.

What is certain is that a small company’s decision to fight a battle over refilled ink cartridges will now affect the business decisions of organizations across the United States.



34, chemin des Colombettes
P.O. Box 18
CH-1211 Geneva 20
Switzerland

Tel: +41 22 338 91 11
Fax: +41 22 733 54 28

For contact details of WIPO's External Offices
visit: www.wipo.int/about-wipo/en/offices/

WIPO Magazine is published bimonthly and distributed free of charge by the World Intellectual Property Organization (WIPO), Geneva, Switzerland. It is intended to help broaden public understanding of intellectual property and of WIPO's work, and is not an official document of WIPO.

The designations employed and the presentation of material throughout this publication do not imply the expression of any opinion whatsoever on the part of WIPO concerning the legal status of any country, territory or area or of its authorities, or concerning the delimitation of its frontiers or boundaries.

This publication is not intended to reflect the views of the Member States or the WIPO Secretariat.

The mention of specific companies or products of manufacturers does not imply that they are endorsed or recommended by WIPO in preference to others of a similar nature that are not mentioned.

For comments or questions, contact The Editor at WipoMagazine@wipo.int.

To order a print version of the WIPO Magazine, contact publications.mail@wipo.int.

WIPO Publication No. 121(E)
ISSN 1020-7074 (print)
ISSN 1564-7854 (online)