

# WIPO | MAGAZINE

N° 3 - JUNE - 2013



Berries, beverages &  
**BRANDING** p.18

**TRADE SECRETS: THE OTHER IP RIGHT** p.2 | **BUILDING IP  
AWARENESS IN ANTIGUA AND BARBUDA** p.9 | **WHAT DOES IT  
COST TO DEFEND YOUR IP RIGHTS?** p.23



# CONTENTS

---

- p.2 Trade Secrets: the other IP right
- p. 5 Fast-tracking green patent applications
- p.9 Building IP awareness in Antigua and Barbuda
- p.14 Why update the IP rights of broadcasters?  
– A view from Asia
- p. 18 Berries, beverages & branding
- p.23 What does it cost to defend your IP rights?
- p.28 In the courts: Monsanto v. Bowman:  
Supreme Court upholds patent holders' rights
- p.30 In the news

Acknowledgements:

- p.5 **Carsten Fink**, Economics and Statistics Division, WIPO
- p.9 **Omar Katbi**, Communications Division, WIPO
- p.14 **Carole Croella**, Copyright Law Division, WIPO
- p.18 **Francesca Toso**, Department for Africa and Special Projects,  
**Matthijs Geuze**, Brands and Designs Sector, WIPO
- p.28 **Philippe Baechtold**, Patent Law Division, WIPO

Editor: **Catherine Jewell**  
Graphic Designer: **Annick Demierre**

Front cover image:  
Credit: [www.chileflora.com](http://www.chileflora.com)  
Aba Distil's new brand of beverage,  
Maquire®, combines pisco and the maqui  
berry which grows wild in the Araucania  
region of Southern Chile.

© World Intellectual  
Property Organization

# TRADE SECRETS

---

## the other IP right

---

*By James Pooley,  
Deputy Director General, Innovation  
and Technology Sector, WIPO*

What kind of intellectual property (IP) is most often relied on by business to protect competitive advantage? Most people would answer with one of the best known areas of IP: patents, copyright, trademarks or designs. But they would be wrong. The most common form of protection used by business is secrecy.

Why then do trade secrets receive less attention than the other areas of IP? There are several reasons. First, secrecy does not involve a government registration process; it is implemented as a matter of practice by each business. Second, although the general principles of trade secret law – also referred to as the law of undisclosed, or confidential, information – are established in similar ways in most countries, there are few common rules or regulations about enforcement. Third, secrecy disputes are usually secret, so they do not become part of the public debate.

Recently, however, trade secrets have shot to the top of the news, with stories of “cyber-espionage” attacks on companies throughout the world, with spies using fake email messages to get inside corporate networks and trawl for useful information. But trade secret law is also getting a fresh look for more positive reasons, as a framework that can enable collaborative innovation, often involving actors located in many different countries. Whatever the catalyst, governments and industry are clearly interested. Within the last year, major initiatives on secrecy have been launched by the European Commission as well as the US government.

### **JUST WHAT IS A TRADE SECRET?**

Most simply, a trade secret is information that you do not want the competition to know about. The law generally protects not just secret formulas and designs, but even simple facts, such as the features that might be introduced in the next iPhone, or which country a business intends to go into next.

Secrecy has been a part of trade for thousands of years. For example, secrecy allowed a region of China to profit for centuries from clever harvesting of the silkworm’s thread, and it gave a family from Armenia a 400-year lead in producing the best orchestral cymbals.

Trade secrecy is a legal regime that protects relationships of trust. Before the industrial age, innovative craftsmen would keep their “tricks of the trade” closely held through small, family-owned shops. However, as industry moved from the cottage to the factory, there was need for a legal system that would enforce an employee’s promise of confidence about a secret process or piece of machinery.

It is important to keep in mind that secrecy is a legitimate tool for businesses of all sizes. Enforcing business secrets has nothing to do with lack of transparency in government. Although it may seem paradoxical, trade secret laws can enable and encourage technology transfer, because they provide a commercially reasonable way to disseminate information. Although some aspects of secrecy laws, such as data exclusivity for drug companies (Art. 39.3 of the Agreement on Trade-Related Aspects of Intellectual Property Rights (TRIPS Agreement)), can be controversial, there is general agreement that confidential disclosure is beneficial in a modern economy. Indeed, keeping secrets – often information about customers and their needs and



Photo: istockphoto © laughingmango

Secrecy has been a part of trade for thousands of years. Trade secrecy is a legal regime that protects relationships of trust. Secrecy allowed a region in China to profit for centuries from clever harvesting of the silkworm’s thread.

preferences – is the main way that small and medium-sized enterprises (SMEs) protect their business advantage.

It is easier to understand this point if you imagine what it would be like if no one could count on the law to enforce obligations of confidence. Businesses would hire fewer people, since each new employee would expand the risk of information loss. The cost of enforcing physical security – locks, fences, etc. – would increase. Perhaps most important, many licensing transactions and research collaborations would never happen, because there would be nothing to ensure that partners would not run off with the new technology and unfairly compete against its creator. The general approach would be to hoard information, slowing the progress of innovation.

#### WHY USE SECRECY?

Why do businesses turn most often to secrecy to maintain their advantage? First, it is cheaper than other forms of IP that require registration with a government agency, often with the expense of hiring lawyers or other professionals. In contrast, to establish your trade secret right, all you need to do is be careful with it, spending only what is necessary to keep it from becoming generally known. Usually keeping facilities secure and getting nondisclosure agreements from employees and vendors is enough.

In addition, much more information can be protected through secrecy than is possible with patents, which can only be granted for truly novel technical innovations. Secrecy covers any information that gives you an advantage, even if someone else is already using it; the only limitation is that it not be generally known.

That point reveals the downside of secrecy: there is no guaranteed exclusivity. If someone else discovers your secret without stealing it from you, there's nothing you can do about it, although for most businesses this is not a significant drawback.

#### LEGAL PROTECTION

Trade secret law, like other forms of IP, is governed by national legal systems. However, international standards for protecting secrets (called “undisclosed information”) were established as part of the TRIPS Agreement in 1995. Article 39 of the agreement provides that member states shall protect “undisclosed information” against unauthorized use “in a manner contrary to honest commercial practices” (this includes breach of contract, breach of confidence and unfair competition). The information must not be generally known or readily accessible, must have

value because it is secret, and must be the subject of “reasonable steps” to keep it secret. This general formula for trade secret laws has been adopted by well over 100 of the 159 members of the World Trade Organization.

**“Although it may seem paradoxical, trade secret laws can enable and encourage technology transfer, because they provide a commercially reasonable way to disseminate information.”**

Articles 42 to 49 of the TRIPS Agreement cover enforcement, requiring that civil judicial proceedings be available to enforce all IP rights and that “confidential information” be protected from disclosure. Nevertheless, because national judicial systems, including the methods for granting access to evidence, vary greatly, enforcement of trade secret rights around the world is generally viewed as uneven.

#### CYBER ESPIONAGE

The practical challenges of protecting secrets are more difficult to overcome than the legal ones, however. Paradoxically, the great explosion of innovation that has brought so many benefits to the world has also made it easier for thieves to steal valuable business information. For example, through a process known as “spear-phishing”, commercial spies send an email using personal information gleaned from Facebook or other social media, leaving the recipient unaware that the message is a hoax. Once the embedded link is clicked, the thief’s malicious software, known as “malware”, invades the recipient’s computer and through it the employer’s network. Staying in the computer system for months or sometimes years, this silent invader searches for important confidential files and passwords, and sends all of it back to the hackers who use or sell the information.

Tracing the source of cyber-espionage is notoriously difficult, given the ubiquity and anonymity of the Internet. Estimating





Keeping secrets is the main way that SMEs protect their business advantage.

damage to businesses is likewise challenging, in part because many enterprises do not know that their systems have been compromised, and also because those who do are often reluctant to report it. Nevertheless, studies show that the problem is growing, and governments around the world are looking for ways to address it.

For businesses, the issue is not just about protecting their own valuable information, but about avoiding being infected by secrets belonging to others. In a global market characterized by easy movement of employees and complex webs of connections among companies' suppliers and customers, it takes special vigilance to avoid contamination by unwanted information. Greater competition also means that businesses have to work continuously on finding ways to exploit their secrets, either through direct commercialization, collaborations or licensing. In the meantime, the sheer volume of potentially valuable data creates its own challenges of inventory and valuation.

For businesses that rely on patent protection, secrecy is a critical part of the innovation process. Because most national patent laws require "absolute novelty", this means that until the day a patent application is filed, the invention must be completely protected from any public disclosure. Where the technology requires refinement through experimentation outside the laboratory, this can be extremely difficult. That is why discussions regarding international patent law harmonization often include the idea of a "grace period" of up to one year before filing, during which time disclosures by an inventor will not disqualify a later patent application.

**“It is in the rapidly-expanding realm of international open innovation that trade secret laws may be turned to greatest advantage, particularly for smaller firms and individual inventors from developing and least developed countries.”**

#### ADVANTAGES FOR SMES

It is in comparing patents and secrecy that one can most easily see the importance of trade secrets for SMEs. Patents have been key to the success of many businesses, particularly as they reach into global markets where a period of exclusivity is needed to recoup the cost and risk of innovation. That sort of advantage is greatly amplified when using the Patent Cooperation Treaty (PCT), the international patent filing system administered by WIPO, which gives applicants up to 30 months to refine their plans and find partners and sources of funding. However, patents are not the only tool for protecting technological advantage. Secrecy can do this too, through licensing and various forms of collaboration.

Indeed, it is in the rapidly-expanding realm of international "open innovation" that trade secret laws may be turned to greatest advantage, particularly for smaller firms and individual inventors from developing and least developed countries. These actors often can leverage their special creativity and local knowledge most effectively by collaborating with large, well-established multinational corporations that are looking for fresh ideas. That kind of partnering – the building of "trusted networks" of SMEs and other innovators – is enabled by national trade secret laws that protect the integrity of shared information.

Emerging from a long period of relative obscurity, the subject of trade secrets is currently getting a lot of attention. There is good reason to be concerned about commercial espionage, because like other forms of piracy it disrupts markets and slows progress. But another reason to focus on secrecy is for what it can do to support and amplify the creative work of individuals and SMEs throughout the world, by making it possible to connect with other firms to deliver innovative solutions to the public. ♦

# FAST-TRACKING

---

## green patent applications

---

Promoting environmentally-friendly innovation has become a key priority in national and international environmental policy. Intellectual property (IP) regimes, particularly patent laws, are perhaps the most important of the regulatory vehicles that promote technological innovation. For this reason, a number of national IP offices have put in place measures to fast-track “green” patent applications. The first program was established by the UK in May 2009. Australia, Israel, Japan, the Republic of Korea (ROK) and the US followed in the same year. More recently, Canada (in March 2011) and Brazil and China (in 2012) launched similar programs. Under these programs, the time needed to obtain a patent can be significantly reduced – from several years to just a few months.

This article presents the main findings of two papers, recently published by the authors, about the green patent fast-track programs. The first study (Dechezleprêtre, 2013), published by the International Centre for Trade and Sustainable Development (ICTSD), provides the first empirical analysis of these fast-track procedures, based on data from Australia, Canada, Israel, Japan, the ROK, the UK and the US. The second paper (Lane, 2012), published in the *Berkeley Technology Law Journal* (BTLJ), analyzes the rules governing the various programs, in terms of eligibility requirements and process parameters, and recommends that the programs be harmonized to make their rules uniform across all national IP offices

### OVERVIEW OF THE PROGRAMS

To best understand and analyze the programs, it is helpful to separate out the two major categories of program rules: eligibility requirements and process requirements.

### ELIGIBILITY REQUIREMENTS

Eligibility requirements determine which patent applications may participate in the fast-track programs. In particular, subject matter eligibility defines the categories of green technology that qualify for accelerated examination. The type of technology for which accelerated examination can be requested differs widely across patent offices. In Australia, Canada and the UK, all environmentally-friendly inventions are eligible. The applicant must simply submit a letter explaining why the invention has environmental benefits. However, Brazil, China, Japan and the US place some restrictions on the technologies permitted. For example, only energy-saving and carbon-saving technologies are allowed in Japan. In contrast, the ROK has the most stringent requirements, including a framework of specific enumerated technology classes. In the ROK, technologies (in particular renewable energy) are generally eligible only if the invention is funded or accredited by the government, or given “green certification” by relevant government environmental laws. The Israeli program also defines subject matter eligibility by strictly enumerated technology classes, although it does not have a funding or certification requirement.

### PROCESS REQUIREMENTS

Process requirements are non-subject matter restrictions, such as limitations on the number and type of claims permitted and such parameters as fees and costs. These requirements vary considerably among programs. While IP Australia and the Canadian

By **Antoine Dechezleprêtre**,  
*Grantham Institute of Climate Change  
 and the Environment, London School of  
 Economics (UK)* and **Eric Lane**, *Patent  
 and Trademark Attorney at McKenna  
 Long and Aldridge, San Diego (US)*

#### Further reading:

Dechezleprêtre, Antoine, 2013. Fast-tracking Green Patent Applications: An Empirical Analysis; *ICTSD Programme on Innovation, Technology and Intellectual Property, Issue Paper No. 37*, International Centre for Trade and Sustainable Development, Geneva, Switzerland.

Lane, Eric, 2012. Building the global green patent highway: a proposal for international harmonization of green technology fast track programs. *Berkeley Technology Law Journal* 27:3.



Photo: iStockphoto © nadia

Measures to fast-track “green” patent applications can reduce the time needed to obtain a patent from several years to just a few months.

Intellectual Property Office (CIPO) allow an unlimited number of claims, for many applicants, charges per claim, as imposed by the Japan Patent Office (JPO), for example, may make the cost of larger claim sets prohibitive. Similarly, IP Australia and CIPO are relatively liberal as to unity of invention (the requirement that a patent application relate to only one invention or to a group of closely related inventions), while the JPO is stricter in this regard. Most programs charge no additional fee for accelerated examination. However, some offices require that applicants conduct a prior art search and a comparison of the claimed invention with the closest prior art. This effectively transfers part of the patent office’s work to the patent applicant.

## RESULTS

Since 2009, accelerated examination under the various programs has been requested for over 5,000 patent applications. The United States Patent and Trademark Office (USPTO) received the highest number of requests (3,533) followed by the UK Intellectual Property Office (UKIPO), with 776, and the Korean Intellectual Property Office (KIPO), with 604 (see Table).

The evidence shows that fast-track procedures reduce the time from filing to grant by several years compared to ordinary examination. The time to grant is cut by between 42 percent and 75 percent across fast-track programs, with the shortest time to grant delivered by the UK.

For most programs, a very small share of eligible patent applications was submitted under the accelerated procedures: between one and two percent in Australia, Canada, Japan and the ROK. However, percentages were substantially higher in the UK (20%), Israel (13%) and the US (8%).

## WHY THE LOW PARTICIPATION?

This low participation rate may seem surprising as a fast-track examination process offers several advantages, such as facilitating licensing and making it easier to raise private capital and enforce a granted right against infringers.

There are, however, some disadvantages in accelerating the granting of patents. To begin with, accelerated examination may increase costs for patent applicants, especially where they are required to conduct a search report on the prior art (for example, at the JPO) and submit comments that could have ramifications in litigation.

Another problem with fast-track programs is the wide variability in their rules — both in terms of eligibility and formal process requirements. Applicants seeking to participate in several of the programs must analyze a number of different rules, determine whether their invention meets each program’s eligibility requirements, and draft different claim sets and arguments for each program. As a result, deciding whether and how to use such programs can be costly and time-consuming.

Moreover, it is not always in the applicant’s best interest to have a patent published or granted as soon as possible. Although inventors may want to file a first (“priority”) application right away (because, until they do, they have nothing but secrecy to protect them from imitators), they may also have legitimate reasons for delaying the grant of a patent.

These disadvantages explain why only a small percentage of eligible patent applications are submitted to fast-track programs. Once a patent application is filed, infringers will be opposed on



the basis of the application date and not the grant date. Most applicants therefore have an incentive to wait until the examination is conducted under the regular procedure. As a consequence, patent applicants would only have an interest in using fast-track programs under specific circumstances (such as suspicion of infringement, to raise capital or to secure commercial partnerships).

An important advantage of a long examination period is that it delays the costs associated with the grant of the patent. It also gives patent applicants time to determine whether the patent will be commercially viable before requesting the grant in the first place.

Another major benefit of delayed examination is that it allows applicants to adjust the patent application – in particular the list of claims – during the examination process. If granted too early, the claims of the patent might not perfectly match the final version of the invention, thus facilitating circumvention.

Since patent applications must be disclosed when the patent is granted, an early grant occurring before the end of the 18-month period after which patent applications are normally published could increase the risk of competitors being able to quickly design competing technology. Our interviews with patent attorneys revealed, however, that this is unlikely to be an issue in practice. Most requests for accelerated examination occur before this 18-month period – a further indication that early publication is not viewed as a serious issue by applicants.

## TYPES OF TECHNOLOGY

Technologies relating to climate change, particularly renewable energy, comprise the vast majority of fast-tracked patents, with some variations across countries. In the US, the majority of fast-track requests involve wind power technology, while carbon capture and storage are popular in Australia and Canada. Other environmental technologies – such as recycling or pollution-control technologies – represent around 20 percent of patent applications, except in Israel where 30 percent of applications cover water-saving technologies.

Time to grant

## PROGRAM USERS

The vast majority of participants are domestic applicants, with only small percentages applying to fast-track programs from abroad. This suggests that foreign applicants may be unaware of the programs and that applicants may only want to expedite the first application, which is usually filed in their home country. It is proposed that harmonization of the programs would boost participation – particularly across borders. Compared to companies that do not request accelerated examination, fast-track users tend to have smaller revenues and faster-growing assets. Fast-track programs seem therefore to be particularly appealing to start-up companies in the green technology sector that are currently raising capital but still generating a small revenue.

## HIGH-VALUE PATENTS

Fast-tracked patent applications seem to involve technologies of significantly higher value than other green technology-related patent applications filed at the same time but for which accelerated examination was not requested. Patent applications processed

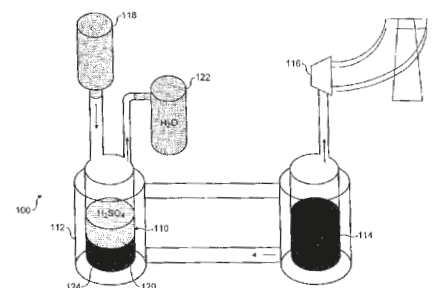
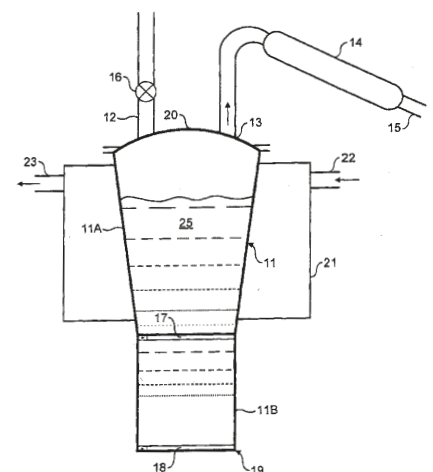

The first patent application (GB 2437148B) submitted under an accelerated procedure relates to a method of heat generation that does not directly use fossil fuels. Invented by Josef Tapper, it is also the first patent granted under such a procedure.

under the fast-track procedures are filed in more countries on average and are also more likely to be filed in all major patent offices (the European Patent Office (EPO), the JPO and the USPTO). These results suggest that applicants tend to request accelerated examination for patent applications involving high-value inventions that may be attracting early commercial interest from potential business partners.

### GREEN TECHNOLOGICAL KNOWLEDGE DIFFUSION

Using forward citations as a measure of knowledge spillovers, we find that within the same period, fast-track patents receive more than twice as many citations as patents of similar value filed through the traditional route. This indicates that fast-track programs have accelerated the diffusion of technological knowledge in green technologies in the short run (i.e., during the first years following publication of the patents). Given the urgency of addressing environmental challenges, this result is encouraging. Whether the effect will be the same in the long run remains an open question.

### NEXT STEPS

The high participation rate in the UK shows there is a clear demand for fast-track programs, even if only a minority of applicants has an interest in using them. How might participation be enhanced at other patent offices?

Given the burden on applicants to understand and satisfy a disparate set of expedited examination program rules, we believe that a standardized, global system of green technology fast-track requirements would be a major boost to participation in such programs. A harmonized system would provide a single set of rules that would apply to all IP offices offering expedited examination for green patent applications. A balanced system would couple broad subject matter eligibility requirements (to include as many useful green technologies as possible) with reasonable process restrictions (to keep examiners' workloads at manageable levels), and thereby maintain sufficiently high-speed examination. In a harmonized system, the applicant need only prepare one submission to apply for accelerated examination in any number of participating offices. By eliminating a substantial burden on applicants, a standardized, balanced international system of expedited examination would encourage greater participation in green technology fast-track programs. It would also reduce the time to grant for a larger number of green patents, thereby fostering development and diffusion of green technologies. ♦

Table: Participation in fast-track programs

Country	Starting date	Number of requests (as of August 2012)	As a percentage of eligible patents
UK	May 2009	776	20.91%
Australia	September 2009	43	0.76%
ROK	October 2009	604	1.88%
Japan	November 2009	220	1.48%
US	December 2009*	3533	8.22%
Israel	December 2009	78	13.13%
Canada	March 2011	67	1.64%

\*The USPTO program was temporary and closed after the 3,500<sup>th</sup> application was received.

# Building IP awareness in ANTIGUA & BARBUDA

By *Catherine Jewell*,  
Communications Division, WIPO

Antigua and Barbuda, nicknamed the Land of 365 Beaches lies between the Caribbean Sea and the Atlantic Ocean. This twin-island state boasts a rich cultural heritage, a vibrant music scene, and some of the world's foremost athletes, including cricket legend Vivian Richards. With an economy dominated by tourism, financial services and a burgeoning information and communications technology (ICT) sector, how is intellectual property (IP) relevant to this country with a population of just over 85,000 inhabitants? What is being done to leverage the value of its creative sector and to raise the IP awareness of the islanders? **Senator Joanne Massiah**, Minister with responsibility for intellectual property, and **Ms. Ricki Camacho**, Registrar at the Antigua and Barbuda Intellectual Property and Commerce Office, explain.

## *Why is IP important to Antigua and Barbuda?*

**Senator Massiah:** We see IP as a way to expose the creativity of our people and to significantly boost the country's economic prospects, especially where the creative industries are concerned. The government is firmly committed to guaranteeing that the IP rights of our creators and inventors are fully protected by ensuring that the requisite legislation and regulations are in place. The Caribbean region is known for its rich literary and artistic works, its calypso, reggae and dancehall music and its heritage. Many of the region's resources remain untapped and we want to ensure that an effective IP system is in place so that we can fully leverage their economic value for the good of the nation and our people.

## *What are your main IP priorities?*

**Ms. Camacho:** A major priority for the government has been to establish a modern, fully-equipped IP office and deliver a comprehensive range of IP services. We are in the process of reviewing our IP legislation to identify those areas that need to be strengthened to ensure that we are compliant with the Agreement on Trade-Related Aspects of Intellectual Property Rights (TRIPS) and the European Economic Partnership Agreement.

I have learned, however, that building an effective IP system and encouraging its use by local entrepreneurs is an ongoing effort and an evolving process. You just have to keep going, learn from mistakes along the way and try to be as engaged as possible with those persons who use our services to get a better understanding of their needs.

**Senator Massiah:** We are also taking steps, with WIPO's support, to register our national fruit – the renowned Antigua Black Pineapple, purported to be the sweetest in the world - as a geographical indication. The sweetness and texture of the black pineapple - so-called because of the dark loamy soil in which it grows - is second to none. Agronomists claim that the prevailing conditions in the area of the island in which it is grown give it its uniqueness. Of course, we want to extract and exploit the full IP potential this distinctive, high-quality fruit offers.

**Ms. Camacho:** Improving IP awareness is another priority. We remain unrelenting in our efforts to ensure that our policymakers and the general public fully understand the importance of IP. Changing perceptions about the role of IP and creating an understanding about its relevance to almost every facet of life, to economic growth and national development, is an ongoing challenge.

We find that although IP has become a buzzword in our society, there is still a lot of confusion about IP rights. People often say they want their copyright protected when in fact they want to register their trademark. Or they say they want to publish an idea for a technology, failing to understand that this would destroy its novelty and make it impossible to obtain a patent. We have devised various public information strategies to help people understand that different types of IP rights protect different aspects of a product.

## *How do you build IP awareness?*

**Senator Massiah:** A few years ago, we recognized that if we could get our young people to understand and appreciate the value of IP and stimulate their own sense of creativity by rewarding them in some way, we could instill in them, from a very young age, an appreciation of what IP is and why it is important. This would also help build greater respect for other people's property - including their IP - and create excitement about tapping into their own creativity.

Our annual World IP Day activities are central to our outreach efforts. For the last two years, in collaboration with Scotia Bank, we have held essay competitions for primary and secondary school students. These competitions have been extraordinarily successful, particularly at the primary school level, and are activities we want to expand on and develop further.

**Ms. Camacho:** We are now building on past successes and taking advantage of the opportunities afforded by media platforms, such as YouTube and Facebook which seem to touch the lives of most young people, as well as, of course, local TV and radio networks and websites, to get our message across.

This year we worked with a hip, young producer and other local artists to put together a series of IP awareness campaigns focusing on different aspects of the IP system in the run up to World IP Day 2013. Our message had to be catchy and one people could relate to. Essentially, we gave them a free hand in the creation and development of the message. One of the key lessons I drew from this is that you have to stand back and allow the artist to be creative. That's what they do best. We were in awe of the final result.

For them it was clear from the outset that by using faces people know and respect, the campaign would become viral, so they got many different, well-known personalities involved: the very popular young local soca singer, Drastic, who also supported our education campaign by visiting schools and sharing his experience in the music industry and explaining why protecting IP is important; the artist, Heather Doram, who designed our national dress; the poet, Toya Turner; a calypso band; and film creator Bert Kirschner who puts together film festivals on the island. The impact has been amazing.

Using artists to communicate the messages through TV, radio, video and social media made for a vibrant and extremely effective campaign. Working with a dynamic public relations firm that knew how to craft our message into something that resonated with our main target audience, the young, significantly boosted the success of our campaign this year.

The activities we organize in the run up to World IP Day each year are really important in Antigua and Barbuda. The support of Scotia Bank through its Bright Future Program™ and other corporate partners, such as LIME, which donated a telephone to the winner of the secondary school essay competition, is invaluable. World IP Day is the one time in the year when the media gets really excited about IP. They support all our events and are genuinely interested in what we are doing.

### ***How would you like to see your IP awareness campaigns evolve?***

**Senator Massiah:** In the future, we envision featuring many more artists in our awareness campaigns and have them endorsed by leading policymakers. Ideally, we would like to see this initiative expanded throughout the territories of the Organization of Eastern Caribbean States (OECS) because, as a region, the various products, talents and creations that we bring to the world really are in dire need of better protection. If the region's artists came together, we could send a very powerful message about the importance of IP and our united commitment to protecting the rights of creators.



The young soca singer, Drastic, supported the education campaign of Antigua and Barbuda's IP and Commerce Office by visiting schools and sharing his experience of the music industry and explaining why IP is important.

The Antigua Black Pineapple which grows in dark, loamy soil, is renowned for its sweetness. With WIPO's support, the Government of Antigua and Barbuda is seeking to register it as a geographical indication.



“World IP Day is the  
one time in the year when  
the media gets really  
excited about IP.”



Antigua and Barbuda is famed for its pristine beaches. To leverage the economic value of the country's many untapped resources, the government is working to ensure that an effective IP system is in place.

---

Regrettably, what we have observed in Antigua and Barbuda in relation to piracy is that a lot of artists adopt an “if you can't beat them, join them” attitude. Many vendors openly sell pirated music on street corners. Some artists approach them saying, “if you are going to steal my music, let's enter into some sort of an arrangement where you give me a percentage of what you make”. That really is not the right approach and perpetuates piracy.

We must clamp down on piracy to encourage creativity. We are persuaded that our new approach to raising IP awareness, which emphasizes what it takes to be creative and to produce, is the key to fostering a broad appreciation of artists and their work. While we accept that we may never be able to stamp out piracy or IP theft completely, we can at least work assiduously to substantially reduce this illegal practice.

But to get there, we need to heighten further awareness about the long-term damage piracy causes and work with the local business community to ensure their enforcement activities are ever-more effective. We also need to bring together the various actors within the law enforcement community across the region - customs, police, judges and magistrates - to combine forces and encourage a more coordinated approach to apprehending offenders, reducing and, where possible, stamping out piracy.

**Ms. Camacho:** We need to foster an appreciation of the multi-disciplinary and cross-cutting nature of IP and to develop a more coordinated approach to it within government. We are setting up multidisciplinary committees, such as the Steering Committee on the Antigua Black Pineapple to ensure a more strategic approach to protecting this potentially valuable economic asset. Sadly, IP's economic value is sometimes forgotten amid more immediate economic concerns.

**Senator Massiah:** A multilateral approach is invaluable in establishing the systems, policies and IP awareness initiatives that enable us to protect the rights of artists, inventors and creators. We have had tremendous support from many countries and organizations in our efforts to establish and strengthen Antigua and Barbuda's IP system. There is still much to be done, but we are on the right track and thankful for the assistance which we have received so far. ♦

In 2013, the Antigua and Barbuda Intellectual Property and Commerce Office, in collaboration with Scotia Bank, held essay competitions for primary and secondary school children. Here are excerpts from the winning entries:

Kevin Alexander, Jr., aged 10. Essay theme: Granted special powers to advance to the year 2050, describe the day in the life of a student.

“I got the remote from the bed and pressed the first button. My school uniform was handed to me from the closet, shoes and all. Then I pressed the second button and my school bag appeared from a top shelf. I continue to press more buttons that control the lights, a large digital television screen and my favorite music. It was now 6 o'clock and mom's voice was calling me. [...] I went to the bathroom and a machine arm appeared which brushed my teeth and rinsed them automatically. [...] I am now understanding that everything in 2050 is digital and voice activated. I got dressed, had breakfast and we were off to school.

My mom's car was strange but in a nice way. The doors opened by themselves and we got in. There is no steering wheel, just buttons. My mom placed her hand into the hand print slot and the car started. The jeep came alive and my mom said, “school”, and off we went. The news cast came over a small screen on the way. Antigua did not look the same. [...]. Our cars were flying. It was amazing. We reached school in 5 minutes. [...]

My friends and I went through a screen one by one that scanned us and read our names and our classes. [...] There were no teachers. The chairs and desk had their own little screens and our own hand print area with our names. [...] We all placed our hands in the hand print area and our desk came alive with lights and the first lesson. After the break we did Science, Social Studies and Reading. [...] The big screen told us that school was over. We walked back through the scanner. Mom was waiting and the jeep door opened automatically. We were flying again back home. School in the future is really awesome.”

Terrihia Benjamin, aged 15. Essay theme: Combating the Destructive and Irresponsible Use of Technology

“Technology features in all aspects of our lives. [...] We can say that technology is the life blood of our society. It is in our homes, schools, churches, medical centers and businesses. Technology indeed has the potential to benefit and improve the lifestyle of people in our society. This is clearly seen in the great improvements that have been made in the banking and educational sectors. Technology, however, can be harmful to society when people use it to engage in destructive, irresponsible and criminal activities such as spreading viruses, hacking, cyber bullying and posting inappropriate pictures and materials. In light of this, government agencies, regulatory bodies and designers must take bold and creative measures to combat these negative practices.”



Photos: New Media

Left to right: Mr. Alwyn Crump, Major Account Manager, LIME; Miss Terrihia Benjamin, winner of the Secondary School Essay Competition; and Mr. Gordon Julien, Manager, ScotiaBank.

Left to right: Mr. Alwyn Crump, Major Account Manager, LIME; Mr. Kevin Alexander, Jr., winner of the Junior School Essay Competition, and Mr. Gordon Julien, Manager, ScotiaBank.



PROFILE

7:24:31



FONT A

FONT B

VIZ 3

VIZ 4

GOOD MORNING.  
IT'S 7:25 ON THIS  
FRIDAY MORNING.

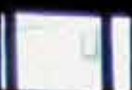

HEMSROOM

X-R

X-B

X-C



Can 1

Can 2



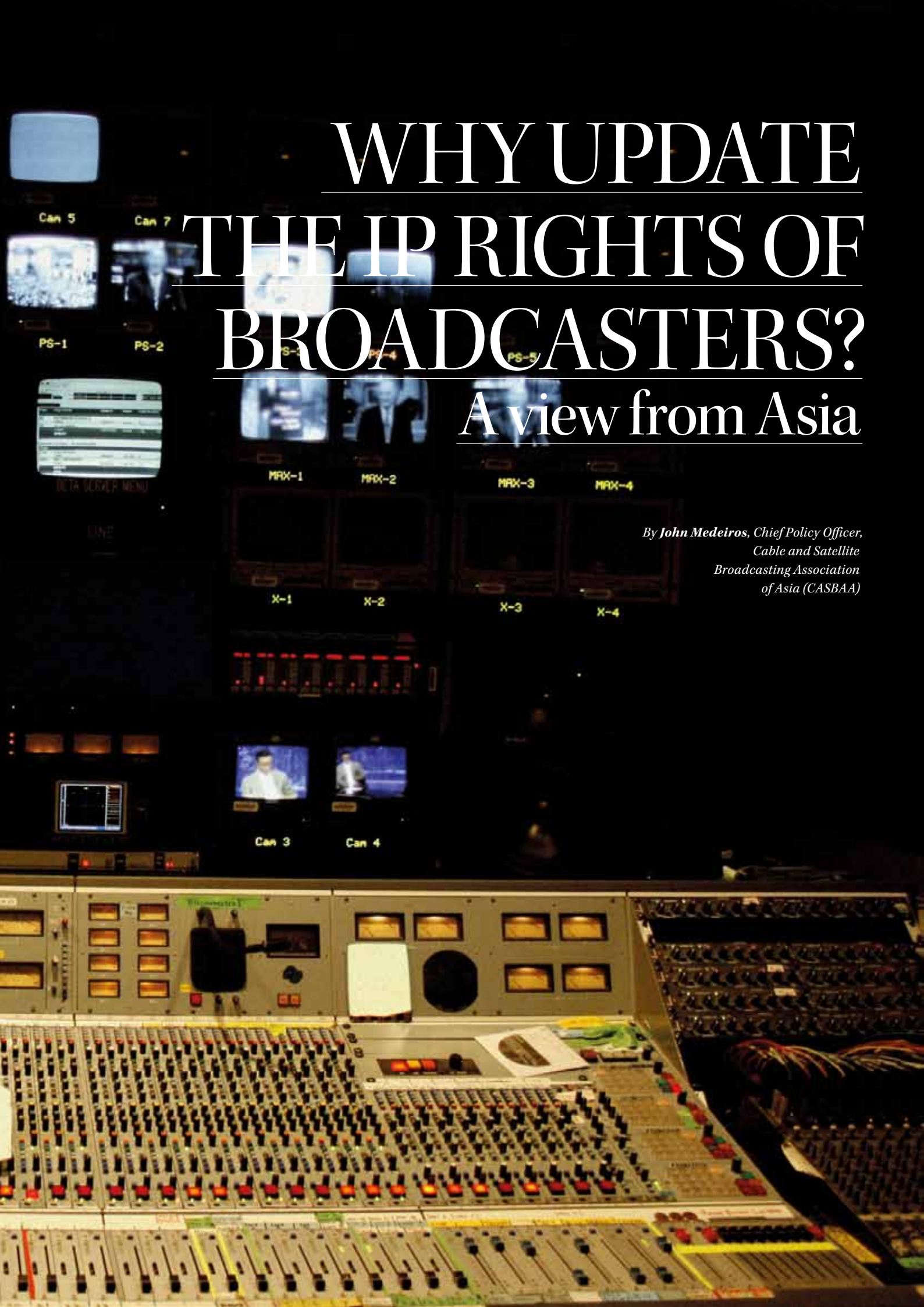

A television control room with multiple monitors and a large mixing console. The monitors display various video feeds, including news anchors and technical data. The mixing console is filled with numerous sliders, buttons, and knobs. Labels on the monitors include 'Can 5', 'Can 7', 'PS-1', 'PS-2', 'PS-3', 'PS-4', 'PS-5', 'MAX-1', 'MAX-2', 'MAX-3', 'MAX-4', 'X-1', 'X-2', 'X-3', 'X-4', 'Can 3', and 'Can 4'.

# WHY UPDATE THE IP RIGHTS OF BROADCASTERS? A view from Asia

*By John Medeiros, Chief Policy Officer,  
Cable and Satellite  
Broadcasting Association  
of Asia (CASBAA)*

Take the smartphone out of your pocket, and look it over. Imagine that the rules for making and using such devices today were the same as those in effect 50 years ago. But wait.....that's not possible. Fifty years ago, nobody had mobile phones! The first handheld public-subscriber telephones were launched in the early 1970s. The first commercial communications satellite was launched in 1962, with direct broadcasting of television from satellites to homes following in the late 1980s. And in the 1960s, the Internet was not even a dream.

So when the current international treaty governing the intellectual property (IP) aspects of broadcast programming, the Rome Convention for the Protection of Performers, Producers of Phonograms and Broadcasting Organizations, was agreed in 1961, no one could foresee the evolution of the global broadcasting environment – or the many ways in which broadcast programming could be grabbed and misused without the broadcaster's consent. The Rome Convention set the international baseline for broadcasters' IP with reference to a world of analog, closed-border, black-and-white broadcasting. That world is long gone, and the treaty protections for broadcasting organizations are in dire need of updating.

Asian broadcasters, like others around the world, believe this need is becoming ever-more urgent as the ways in which Asian broadcast signals are hijacked and sent flashing around the globe – polluting many markets and damaging the interests of broadcasters, creative industries and governments – continue to multiply. Asia is enjoying a huge boom in television consumption, as more and more people are connected to an increasing number of networks and consuming more programming. Broadcast streams are the foundation of that growth, but broadcasters who finance, generate and aggregate those streams are forced to stand by helplessly as others relay their broadcasts – live or deferred, by many different technical means – without their consent and without paying for that use.

#### **WIDESPREAD MISUSE OF BROADCASTS**

The “traditional” means of broadcast signal theft were bad enough – for example, where individual cable companies captured satellite broadcasts intended for paying customers residing in other countries, and distributed them to their own customers at a profit. Now we are seeing the misuse of broadcast programming in a myriad of new ways.

Today we find people riding the subways in Singapore, watching broadcast dramas from the Republic of Korea on their handheld devices in real time – from pirate websites. We find Hong Kong (SAR) dramas and Hollywood movies being streamed to Vietnamese mobile phones. And Malaysian dramas are being rebroadcast across the border in Indonesia,

**“The ability of multinational piracy syndicates to grab broadcast streams and distribute them globally with impunity means that developing-country broadcasters are robbed of actual and potential markets around the world. “**

without any compensation paid to the Malaysian broadcasters who create the content.

It is not just individual works that are being downloaded and stored in “cyberlockers” for mass download at a later date. Increasingly, entire streams of broadcast programming are being pirated and rebroadcast over new types of networks emerging from the growth in global broadband connections and web-enabled “connected TVs” that make it much easier to obtain and consume the pirated programming.

### LEGAL PROTECTION IS A CHALLENGE

In many countries, legal regimes based on the minimal standards outlined in the Rome Convention make it difficult or impossible for broadcasting organizations to obtain protection for their program streams. Since broadcasters as such do not qualify for protection in those countries, any legal recourse depends not on the local broadcasting organization, but on the far-off movie studio, drama producer, historical documentary creator or sports league that owns the original copyright in the content. It is quite frankly neither reasonable nor commercially viable for Asian broadcast generators to have to depend on others to enforce what should be theirs by right.

At the same time, there are a rapidly rising number of websites that simply take broadcasts from a satellite, or from digital free-to-air transmissions, and relay them onto the Internet. These websites are typically located in countries with weak IP protection, but they target audiences in other countries, so are clearly set up for commercial purposes. The stolen programming is used to buttress a host of different business models – with some online operators streaming stolen broadcasts in order to generate page views and advertising revenue on their websites. Others use the programming to drive equipment sales, marketing “connected” devices that enable consumers to view the pirated streams. A growing number seek to monetize the content by charging subscription fees, thereby competing with legitimate broadcasting organizations – and weakening the ability of tech start-ups to compete within the legal ecosystem.

One such start-up went bankrupt not long ago in Japan. Its business model was to sell legal, authorized Indian entertainment to ethnic Indians resident in Japan, who had both the disposable income and the hunger for home programming that should have made the business a success. However, it ran into competition from websites based in neighboring countries that used accomplices in India to steal the programming without the broadcaster’s consent and relayed it to Japan, charging much lower prices. They were leeches, feeding off the creative energies of the legitimate Indian producers.

### FAR-REACHING IMPACT OF IP THEFT

This type of IP theft affects premium broadcasters who seek to repay their investment in programming by charging subscription fees. It also badly damages free-to-air commercial broadcasters and public TV stations whose advertising revenue is siphoned off by web pirates. Government tax receipts also suffer, as the pirates are usually based offshore, outside the tax net.

In today’s interconnected world, even state-owned broadcasters are seeking additional revenue by selling their program streams beyond their home markets. Asian public (and private) broadcasters from places as diverse as China, India, Japan, the Philippines, the Republic of Korea, Thailand and Viet Nam are looking to earn revenue from their ethnic audience pools outside of Asia – in places like Australia, North America and Europe – but are finding it much harder to get through the door, because the broadcast streams are already being relayed by Internet-based pirates.

The final irony, and one which should be of great concern, is that growing global broadband connectivity should be acting to strengthen global cultural exchange and improve exports of cultural goods from developing nations. However, just the reverse is happening. Those markets have economic affluence and sociocultural affinities that should make them fertile ground for sales of home-country cultural products. But the ability of multinational piracy syndicates to grab broadcast streams and distribute them globally with impunity means that developing-country broadcasters are robbed of actual and potential markets around the world.

In addition, in most developing countries, broadcasters also include leading indigenous content producers, so the piracy leaves the creative economy in poor countries even more starved of resources. Domestic cultural creation suffers and, in those countries in which the government chooses to devote its scarce revenue to promoting exports of cultural products, the presence of so much new-style piracy means it is the public treasuries in developing countries that risk subsidizing affluent ethnic consumers overseas, when the flows should move in the other direction.

For all of these reasons, the international broadcasting industry – in all its commercial, technological and cultural diversity – hopes and expects that governments will expedite conclusion of a treaty to protect the rights of broadcasting organizations in the 21<sup>st</sup> century. ♦

# BERRIES, BEVERAGES & branding

By **Catherine Jewell**,  
Communications Division, WIPO

“Sunshine in a bottle!” That’s how Nobel Laureate Pablo Neruda described pisco. ABA Distil, a family-run business in Al Arenal, a small village in Chile’s Elqui Valley, 500 km north of Santiago, has been producing pisco since 1921. In 2011, Alejandro Aguirre, who took over the company from his father 13 years ago, also began developing the latest addition to the company’s product portfolio, Maquire®, combines pisco with the locally-grown maqui berry. Recently, external events temporarily halted the company’s operations and could have devastated it were it not for the power of its brands. ABA Distil’s experience offers a powerful message about the enduring value of brands and why it is important for companies of all sizes to invest in an effective brand strategy.

ABA Distil produces its hallmark pisco from the best muscat grapes grown in the Elqui Valley in the high Chilean Andes. “The grapes are harvested by hand at the end of the summer and, after crushing and destemming, they are turned into wine and double-distilled in small copper pots,” Mr. Aguirre explains. “The alcohol obtained is aged for around 18 to 24 months to round up the flavors. Dilution and filtering are the next steps of the process, and finally the product is bottled, labeled and packed ready for shipment to markets in Canada, China, Japan, New Zealand and the UK.”

The company launched Pisco ABA, its first pisco brand, in 2001. It has since won international acclaim and currently accounts for some 60 percent of the company’s export sales. In addition to Pisco ABA and Maquire®, ABA Distil has four other established product lines, each with its own brand.

In 2011, the company decided to expand its range of products. It developed a new alcoholic beverage, marketed under the brand name Maquire, that combines pisco with the dark-purple maqui berry, also known as Chilean wineberry (*Aristotelia Chilensis*). The fruits are harvested from the abundant maqui bush, which grows wild in the fields and on the hillsides of the Araucania region in southern Chile.

## MAQUI: A SUPERFRUIT

For generations the Mapuche Indians used fresh and fermented maqui juice to treat stomach ailments, fever, sore throats and wounds. Legend has it that thanks to the berry’s healthful properties, the Mapuche Indians were able to withstand the invading Spanish forces and remain the only unconquered people of South.

## About Pisco

*Pisco production dates from the 16th century in what was then the viceroyalty of Peru, an area including present-day Peru and Chile. While Peru claims the exclusive right to use pisco as an appellation of origin, having registered it as such under the Lisbon Agreement for the Protection of Appellations of Origin and their International Registration, various countries that have concluded free trade agreements with Chile allow for the use of pisco in their respective markets, for products from Chile made in accordance with Chilean regulations for pisco designations. These are: Pisco tradicional (60 to 70 proof); Pisco especial (70 to 80 proof); Pisco reservado (80 proof) and Gran pisco (86 + proof). Fewer than 20 Chilean companies currently produce pisco.*

The maqui berry, also known as Chilean wineberry (*Aristotelia Chilensis*), is rich in antioxidants and grows wild in the fields and on the hillsides of the Araucania region in southern Chile.



According to scientific research, the maqui is rich in antioxidants, containing significantly higher levels of anthocyanins and polyphenols than any known food or drink. These powerful compounds offer protection from free radicals and radiation which contribute to aging. The berry contains a high concentration of delphinidin, a potent anti-inflammatory that can help alleviate degenerative diseases, such as arthritis and heart disease. This succulent berry may also be useful in weight management due to its glycemic control characteristics.

In light of its high oxygen radical absorbance capacity values, which are between 4 and 30 times higher than those of other berries such as acai, goji and mangostan, maqui berries have been billed as the quintessential superfruit, gaining popularity in the food and beverage industry, especially in the US.

ABA Distil is also working with a group of researchers from the University of Concepción to appraise the impact of the delphinidins in the maqui berry on Alzheimer's disease. "Our aim is to certify that Maquire® can have a positive impact on human health," explains Mr. Aguirre. By combining pisco with maqui berries, Maquire® is "a smart drink that not only promises fun but also a very convenient dose of anthocyanins," he says.

## A BRAND IS BORN

The brand name "Maquire" - pronounced "makwaier" - is made up of the words "maqui" and "Aguirre" and was chosen for its sophisticated ring. It was developed with the support of the Korean Intellectual Property Office (KIPO) in the framework of the One Village One Brand initiative of the Asia-Pacific Economic Cooperation (APEC). The project aims to spread understanding of the importance of using intellectual property (IP) rights to bring economic benefits to producers and the local community in developing economies. ABA Distil was one of two case studies used in the project as a basis for developing strategic branding guidelines and best practices for companies operating in both developing and least developed economies (see <http://tinyurl.com/Int2mvx>).

Within the framework of the One Village One Brand initiative, the company received advice and guidance in developing the brand name, symbol and bottle design for its new product. Together with a team of specialists from the Republic of Korea (ROK), the company began developing its new brand. "We started from scratch," notes Mr. Aguirre. "When our Korean friends visited our vineyards and production facilities, we thoroughly discussed our ideas. At first we didn't have a face or a name

to bring the product to market, so we needed to develop all of the elements for the product to speak for itself."

The process involved a thorough analysis of the market, including identifying other commercially available maqui berry-related products and consumer preferences. ABA Distil is well placed to test the likes and dislikes of consumers, as the company's vineyards are visited year-round by thousands of tourists wishing to savor the region's products.

Various candidate names for the new product were evaluated on the basis of research, internal discussions and reviews by trademark experts, who checked for other similar trademarks and any negative meanings. "We discussed the concepts behind each of the names and design motifs. It was not easy because many of them were quite appealing, but we had to make a decision. Finally we came up with a wonderful design and a smart brand name which is intuitively attractive," Mr. Aguirre explains.

ABA Distil has now registered "Maquire" as a trademark in Chile and is seeking to do the same in the ROK.

The company also benefitted from guidance in developing a strategy to enhance the competitiveness of its brands, focusing on such issues as how best to position the product in target markets, as well as pricing and brand communication. For example, in terms of the company's aspirations to enter the ROK market, it was noted that, as "Maquire" bears some similarity to that country's "Bokbunja" drink, being sweet and smooth, the product would hold greatest appeal to consumers in the 40 to 60 age bracket.

## DISASTER STRIKES

In October 2012, the company's production facilities were put out of operation by a major flood caused by a breach in a nearby dam. "The water flooded our property, damaged the greater part of our facilities and a small area of the vineyards. It was like we had been hit by a tsunami," Mr. Aguirre explains. "It was a catastrophe for us as a family and as a business."

## THE POWER OF BRANDS

"We soon came to realize that these are moments when your brand, your trademark, comes to assist and sustain you. Even when our physical world had been destroyed and our business was in tatters, we still had our brands and the goodwill and

**“Branding is a never-ending process, but is a ‘must’ for anyone who wants to protect the value of their creations.”**



MAQUIRE’s modern design motif, which includes an illustration of the maqui bush laden with berries, reflects the idea of “the mighty maqui berry”.

The brand name “Maquire”, chosen for its sophisticated ring was developed with the support of the Korean Intellectual Property Office (KIPO) in the framework of the One Village One Brand initiative of the Asia-Pacific Economic Cooperation (APEC).



Photos: Aba Distil



In October 2012, Aba Distil's production facilities were destroyed by flooding. Their robust brand portfolio sustained them.



reputation we had built up over the years. Although the flood was a major setback, we came to realize that it was simply the case that our activity was temporarily suspended. A catastrophe like this may mean you need to rebuild your production facility, but if you have taken the time to invest in and develop your brands, their commercial value and acquired prestige remain unchanged and, in fact, they enable you to get back on your feet more quickly," he explains. "Our efforts to expand our product range by launching Maquire also enhanced the possibilities for us to diversify, better manage commercial risks and expand our business," he added.

"Branding is a never-ending process, but it is of paramount importance to protect brands. It is a 'must' for anyone who creates and wants to protect the value of his or her creation. Some day that creation may become something that many people want and as such may develop into an extremely valuable commercial asset." ♦

### ***WIPO's IP and product branding project***

WIPO's Development Agenda project "IP and Product Branding for Business Development in Developing Countries and Least Developed Countries (LDCs)" also offers practical support to small and medium-sized enterprises (SMEs), in the design and implementation of strategies for the appropriate use of IP in product branding.

The WIPO project seeks to promote the development of local communities and strengthen community and institutional capacity by focusing on the promotion and strategic use of IP in this area. Three countries – Thailand (Handmade in Thailand: building brands for local communities – [www.wipo.int/wipo\\_magazine/en/2012/05/article\\_0002.html](http://www.wipo.int/wipo_magazine/en/2012/05/article_0002.html)), Panama (Panama: Three marks for development – [www.wipo.int/wipo\\_magazine/en/2012/02/article\\_0004.html](http://www.wipo.int/wipo_magazine/en/2012/02/article_0004.html)) and Uganda (Uganda: Branding cotton, sesame and vanilla – [www.wipo.int/wipo\\_magazine/en/2012/03/article\\_0002.html](http://www.wipo.int/wipo_magazine/en/2012/03/article_0002.html)) were selected as beneficiaries of this project.

WIPO is also sharing these experiences with its partners, including KIPO, to optimize the impact of its initiatives.



# What does it cost to defend your IP RIGHTS?

By *Ignacio de Castro*  
and *Judith Schallnau*,  
WIPO Arbitration  
and Mediation Center, WIPO

The continued rise in demand for intellectual property (IP) rights suggests that with an underperforming economy the importance of IP rights is only growing. The expanding commercialization of technology, illustrated by record numbers of international patent filings (see *World Intellectual Property Indicators Report 2012*) points to a long-term trend with inventors increasingly patenting their inventions in multiple countries. The corresponding growth of international business transactions brings with it an increased risk of IP-related disputes. The resources required to handle such disputes can be considerable, especially if the dispute involves litigation in multiple countries. At the same time, such disputes place a serious burden on the continuation and expansion of business. Careful consideration of the risks associated with technology-related disputes goes a long way in preventing, and resolving, disputes. But what is the best strategy to adopt? What are the best practices in this area and what trends are emerging? To gain a better understanding of technology-related dispute resolution practices, the WIPO Arbitration and Mediation Center (WIPO Center) recently conducted an international survey to gauge how alternative dispute resolution (ADR) mechanisms, such as mediation and arbitration, fare compared to court litigation when it comes to resolving such disputes.

“The survey confirms that parties to technology-related agreements are worried about the high costs and lengthy timelines of disputes, especially in an international context,” noted WIPO Director General Francis Gurry at the launch of the survey report. “While court litigation remains the default path, survey responses indicate that ADR offers attractive options in terms of cost and time, as well as enforceability, quality of outcome, and confidentiality,” he added.

The survey offers a number of interesting insights into current dispute resolution practices across a broad range of business areas.

## TECHNOLOGY-RELATED AGREEMENTS CONCLUDED IN THE PAST TWO YEARS

Of the types of agreements listed in the survey, participants most frequently concluded non-disclosure agreements, followed by assignments, licenses, agreements on settlement of litigation, research and development (R&D) agreements and merger and acquisition agreements.

### *About the survey*

*The International Survey on Dispute Resolution in Technology Transactions* ([www.wipo.int/amc/en/center/survey/results.html](http://www.wipo.int/amc/en/center/survey/results.html)) assesses current use and emerging trends in the use of ADR mechanisms compared to court litigation in technology disputes. It was distributed to companies, research organizations, universities, government bodies, law firms, individuals and other entities involved in technology transfer and technology disputes worldwide. It captures data about the types of technology-related agreements concluded in the past two years; the types of disputes arising from these agreements; the methods used to resolve them; and the reasons behind this.

The survey’s findings are based on the 393 responses received by the WIPO Center from small (employing 1-10 people) to large entities (employing over 10,000 people) in 62 countries and operating in many different business areas, including pharmaceuticals, biotechnology, information technology, electronics, telecommunications, life sciences, chemicals, consumer goods and mechanical engineering. In addition to written submissions, over 60 telephone interviews were conducted with stakeholders in 28 countries.

The survey was developed with the support of an expert group comprising in-house counsel and external experts in technology disputes from a broad range of jurisdictions and business areas, various professional associations, including the International Association for the Protection of Intellectual Property (AIPPI), the Association of University Technology Managers (AUTM), the International Federation of Intellectual Property Attorneys (FICPI) and the Licensing Executives Society International (LESI), and with assistance from the WIPO Economics and Statistics Division.



Finding a business solution is the prime objective of companies focusing their dispute resolution strategy on mediation.

The subject matter of such agreements related more often to patents than to know-how or copyright.

Reflecting the globalization of the business landscape, over 90% of participants indicated they had concluded agreements with parties from other jurisdictions, and 80% had concluded patent-related agreements with parties from other jurisdictions on technology patented in at least two countries. The choice of applicable law made in these agreements was influenced especially by the location of the participants' headquarters and the primary place of their operations.

### **AGREEMENTS LEADING MOST OFTEN TO DISPUTES**

The survey shows that while, overall, disputes occurred in relation to some 2% of participants' technology-related agreements, licenses most frequently gave rise to disputes (among 25% of participants). R&D agreements ranked second (among 18% participants), followed by non-disclosure agreements (16%), settlement agreements (15%), assignments (13%), and merger and acquisition agreements (13%). Licensing disputes involving survey participants concerned issues such as the scope and existence of a license, quality standards, profits and determination and payment of royalty rates.

This reflects the experience of the WIPO Center. Forty percent of the technology-related cases handled by the WIPO Center relate to licenses, 7% to R&D agreements and 2% to settlement agreements.

### **CHOICE OF DISPUTE RESOLUTION CLAUSES**

The survey indicates that 94% of the participants negotiate dispute resolution clauses as part of their contract negotiations.

Court litigation is the most common stand-alone dispute resolution clause (32%), followed by (expedited) arbitration (30%) and mediation (12%). Mediation is also included where parties use multi-tier clauses (17% of all clauses) providing for mediation prior to court litigation, (expedited) arbitration or expert determination.

The choice of arbitral institution broadly corresponds to the location of survey participants' headquarters.

In the WIPO Center's experience, 76% of mediation and arbitration cases administered are based on dispute resolution clauses included in existing agreements. These clauses stipulate that future disputes shall be submitted to WIPO mediation and/or (expedited) arbitration. The remaining cases are based on agreements specifically submitting an existing dispute, for example, in relation to patent infringement, to WIPO mediation and/or (expedited) arbitration.

Sixty-six percent of WIPO cases have been based on stand-alone dispute resolution clauses out of which 38% provided for arbitration, 25% for expedited arbitration and 38% for mediation. In 34% of cases, parties included multi-tier dispute resolution clauses providing for mediation, followed by (expedited) arbitration.

## Main Considerations When Negotiating Dispute Resolution Clauses

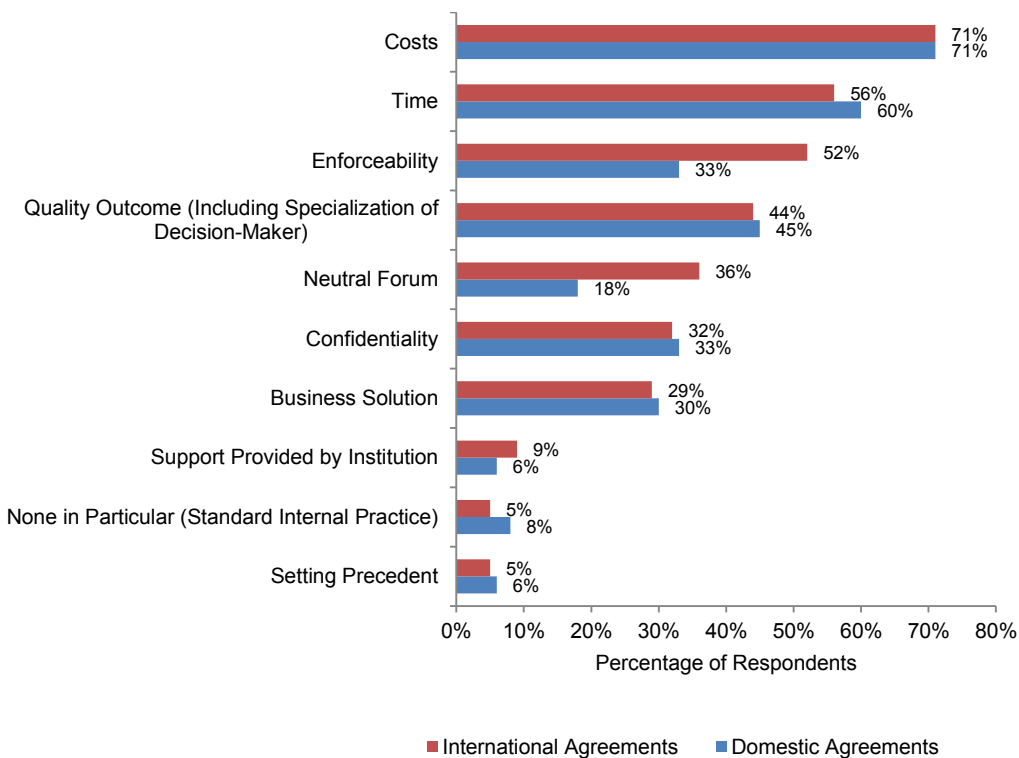

Source: WIPO Arbitration and Mediation Center, International Survey on Dispute Resolution in Technology Transactions

### PRIME CONSIDERATIONS

Cost and time are the prime concerns when negotiating dispute resolution clauses, both in domestic and international agreements. The survey shows that for international agreements, other considerations include enforceability and forum neutrality. Finding a business solution, however, is the prime objective of those focusing their dispute resolution strategy on mediation, both for international and domestic agreements.

### OBJECTIVES OF DIFFERENT PARTIES

For both contractual and non-contractual disputes, patent issues arose nearly twice as often as copyright or know-how issues. The main objectives of claimant parties in patent disputes were to obtain damages/royalties (78%), a declaration of patent infringement (74%), and/or injunctions (53%). The main objectives of respondent parties in patent disputes were a declaration of patent invalidity (73%), a negative declaratory judgment (33%), and/or a declaration of patent infringement (33%).

Some 40% of the WIPO Center's arbitration and mediation cases relate to patents. In these cases - almost all of which are contractual - remedies requested include damages, royalty payments, declarations of non-performance of contractual obligations and/or of patent infringement, a declaration of unenforceability of a patent against a licensee, or, principally in mediation, entering into a contract.

### MECHANISMS USED TO RESOLVE DISPUTES

Broadly consistent with survey findings concerning the choice of dispute resolution clauses, the most common mechanism used to resolve technology disputes was court litigation in both home and foreign jurisdictions, followed by arbitration, mediation, expedited arbitration and expert determination.

The survey participants indicated that they spend more time and incur significantly higher costs in court litigation than in arbitration and mediation. The estimated duration of court litigation in a home jurisdiction was on average 3 years and costs around



**Relative Time and Costs of Resolving Disputes through Court Litigation, (Expedited) Arbitration, Mediation, Expert Determination**

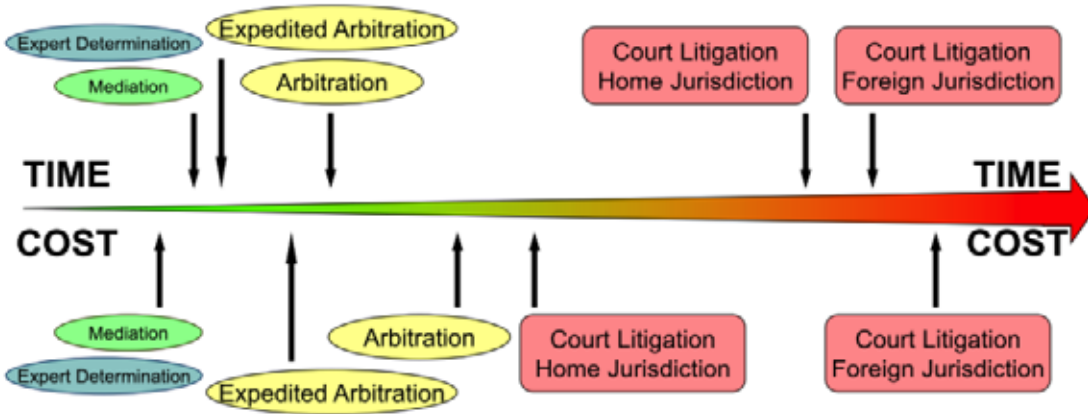

Source: WIPO Arbitration and Mediation Center, International Survey on Dispute Resolution in Technology Transactions

**Relative Use of Court Litigation, (Expedited) Arbitration, Mediation, Expert Determination**

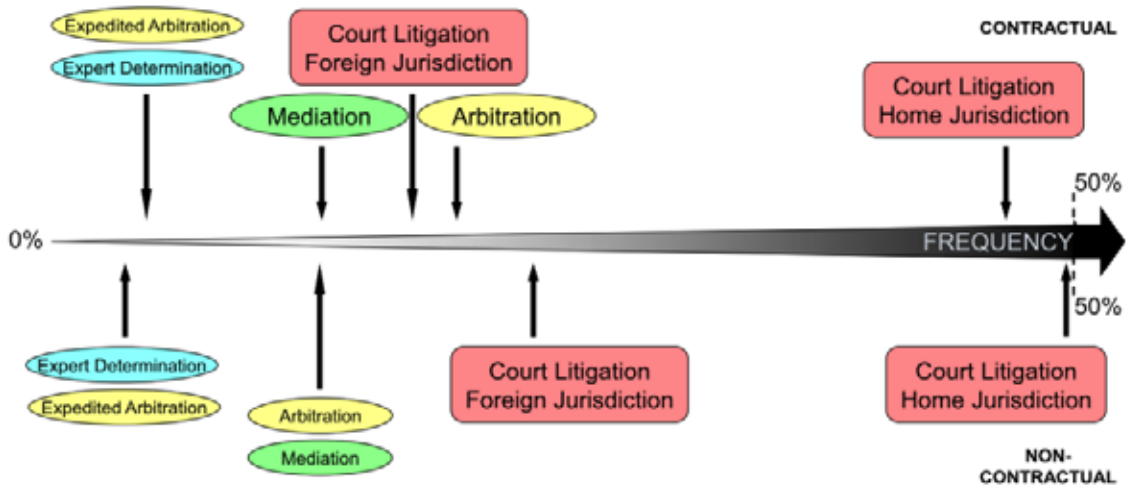

Source: WIPO Arbitration and Mediation Center, International Survey on Dispute Resolution in Technology Transactions

**“Survey participants indicated that they spend more time and incur significantly higher costs in court litigation than in arbitration and mediation.”**

US\$475,000. Litigation in another jurisdiction takes around 3.5 years with legal fees of just over US\$850,000.

In contrast, the survey shows that mediation takes on average 8 months, and in the majority of cases costs less than US\$100,000. Arbitration takes on average just over a year and typically costs around US\$400,000.

By comparison, in the WIPO Center’s experience, mediation under WIPO Rules takes on average 5 months and costs on average US\$21,000. Arbitration cases under the WIPO Expedited Arbitration Rules take on average 7 months and cost around US\$48,000 and cases under the WIPO Arbitration Rules, often involving patents protected in several jurisdictions, take on average 23 months and cost some US\$165,000 (48% of such cases involving a three-member tribunal and 52% a sole arbitrator).

On top of the monetary costs, dispute resolution also ties up the time of business executives and others participating in the proceedings. Involvement in such disputes can also translate into reduced productivity and missed business opportunities.

#### **OBSERVATIONS FOR DISPUTE RESOLUTION IN TECHNOLOGY TRANSACTIONS**

It is clear that no one dispute resolution mechanism can offer a comprehensive solution in all circumstances. Indeed, each transaction is likely to have its own dispute resolution requirements. It is for the parties involved to assess the specific circumstances of a transaction and to determine the most appropriate way to resolve any disputes that may arise. The WIPO Center’s survey, however, does offer some useful guidance for those involved in developing dispute resolution strategies. Key insights include:

- The need to anticipate the risk of disputes in contracts. Although dispute resolution provisions are often regarded as a relatively minor element in contract negotiations, the time and costs associated with any subsequent dispute mean that parties cannot afford to ignore this aspect.
- The need to take account of the risk of foreign litigation and to anticipate the international nature of the parties, rights and law involved.
- The cost of court litigation in a foreign jurisdiction, and sometimes in a home jurisdiction, typically exceeds that of ADR mechanisms. When crafting dispute resolution strategies, it is therefore important, while taking account of the specifics of a given transaction, to focus on keeping costs and time to a minimum.
- Mediation can be a valuable part of a dispute resolution policy, with high settlement rates yielding significant time and cost savings. Adding arbitration as a next step in a multi-tier approach can enhance the chances of settlement if mediation fails.
- In relation to international patent disputes, which have important time and cost implications, when deciding whether to opt for court litigation or ADR mechanisms, it is important to take account of any existing specialized courts and judges, bifurcation of proceedings, availability of injunctions, possible parallel litigation, and enforceability. ♦

MONSANTO v.  
BOWMAN:  
Supreme Court upholds  
patent holders' rights





By **Theresa M. Bevilacqua**, Partner,  
and **Kristin Stastny**, Associate, Dorsey  
and Whitney LLP, Minneapolis, USA

On May 13, 2013, the United States Supreme Court announced its decision in the case of *Bowman v. Monsanto Co.*, Case No. 11-796. The Court's unanimous ruling expressed strong support for the protection of the intellectual property (IP) involved in agricultural biotechnology.

At issue in the case were Monsanto's patented Roundup Ready soybeans, a soybean variety that is genetically modified to have a resistance to the herbicide glyphosate, commonly known as Roundup. Monsanto, as the inventor and patent holder of Roundup Ready soybeans, sells the seeds subject to a limited licensing agreement, whereby farmers are permitted to plant the purchased seed in only one growing season. Growers may then sell or consume the resulting crop, but may not replant it.

Vernon Bowman, a farmer in Indiana, purchased Roundup Ready soybean seeds each year for his first crop of the season from a company affiliated with Monsanto. In compliance with the licensing agreement, Bowman used all of the seed for planting, and then sold all harvested seed to a grain elevator, which would typically resell the crop to an agricultural processor for animal or human consumption. For his second planting, which was late season and therefore more risky, Bowman would purchase significantly less expensive "bin-run soybeans" (soybeans that have been harvested and delivered to a grain elevator and commingled with other soybeans of the same kind, type and quality). Bowman purchased these bin-run soybeans, intended for human or animal consumption, from a grain elevator and planted them in his fields. Because the soybeans purchased from the grain elevator were harvested largely from fields planted with Roundup Ready soybeans, many of the seeds Bowman planted contained the Roundup Ready trait. Bowman would then apply a glyphosate-based herbicide to the fields to determine which plants contained the Roundup Ready trait and save seed from this harvest for replanting the following year.

#### **COURTS REJECT FARMER'S DEFENSE**

Bowman continued this practice for eight planting cycles before Monsanto discovered the practice and sued Bowman in district court for patent infringement. In response, Bowman raised the defense of "patent exhaustion," which gives the purchaser of a patented article, and any subsequent owner, the right to use or resell the article but does not permit the purchaser to make new copies of the patented product. The District Court rejected this defense, and the Federal Circuit affirmed, holding that patent exhaustion did not protect Bowman, because he had "created a newly infringing article." *Monsanto Co. v. Bowman*, 657 F. 3d 1341 (Fed. Cir. 2011).





In its decision, the Supreme Court affirmed that a farmer who buys patented seeds may not reproduce them through planting and harvesting without the patent holder's permission. As the Court noted, were this not the case, an inventor's patent would provide little benefit. "[I]f simply copying were a protected use, a patent would plummet in value after the first sale of the first item containing the invention. . . . And that would result in less incentive for innovation than Congress wanted." *Bowman v. Monsanto* at 8.

#### **PATENT EXHAUSTION NOT APPLICABLE**

The doctrine of patent exhaustion "limits a patentee's right to control what others can do with an article embodying or containing an invention. Under the doctrine, the initial authorized sale of a patented item terminates all patent rights to that item." *Id.* at 4. However, the doctrine "restricts a patentee's right only as to the 'particular article' sold; it leaves untouched the patentee's ability to prevent a buyer from making new copies of the patented item." *Id.* at 5. Applying this doctrine to the facts presented, the Court concluded that: "Under the patent exhaustion doctrine, Bowman could resell the patented soybeans he purchased from the grain elevator; so too could he consume the beans himself or feed them to his animals. Although it was the patent holder, Monsanto would have no business interfering in those uses of Roundup Ready beans. However, the exhaustion doctrine does not enable Bowman to make *additional* patented soybeans without Monsanto's permission." *Id.*

The Court also rejected the argument that its ruling would prevent farmers from making appropriate use of the Roundup Ready seed they buy. Dorsey client CHS, a cooperative operating grain elevators in 16 states, submitted an *amicus* brief, noting that Mr. Bowman's practice of buying bin-run soybeans is atypical and fraught with other issues for the farmer, the grain elevator and the seed companies. The Court noted that Bowman's practice of purchasing commodity soybeans from a grain elevator to grow a new crop was not the ordinary practice among farmers. "[I]n the more ordinary case, when a farmer purchases Roundup Ready seed *qua* seed – that is, seed intended to grow a crop – he will be able to plant it." *Id.* at 9.

#### **NARROW BUT SIGNIFICANT DECISION**

Although Justice Kagan, writing for the Court, emphasized that the decision was narrow, the implications for agricultural biotechnology are significant. The decision provides clarity to the application of patent law in the unique context of biotechnology crops, where the patented technology is naturally self-replicating. Under the Court's decision, the rule that patent exhaustion applies only to the item sold – not to reproductions – applies fully to patented seeds that naturally self-replicate. ♦

The full Supreme Court decision is available at: [www.supremecourt.gov/opinions/12pdf/11-796\\_c07d.pdf](http://www.supremecourt.gov/opinions/12pdf/11-796_c07d.pdf)



## NEW WEBSITE SMOOTHS ACCESS TO MOVIES AND TV ONLINE

In May 2013, the Motion Picture Association of America (MPAA) announced the launch of a new website, *www.WheretoWatch.org*, which allows audiences to get movies and TV shows easily, quickly and legally online. The website lists and categorizes the various services available, summarizing what each platform provides, the content available, how it is supported and the devices with which it is compatible.

Senator Chris Dodd, Chairman and CEO of the MPAA, underlined the importance of delivering content in new and creative ways in a media landscape that offers audiences unprecedented opportunities for viewing content. "Audiences want seamless access to film and TV shows. Our industry has listened, and we are now delivering more choices than ever before," said Senator Dodd. "There have never been more ways to access movies and television legitimately online, and those platforms continue to grow and develop thanks in large part to a copyright system that encourages innovation, risk and growth. The companies I represent are committed to continuing to create and develop the best ways for audiences to enjoy the entertainment they love."

The MPAA is a trade association that serves as the voice and advocate of the American motion picture, home video and television industries. Its members include Walt Disney Studios Motion Pictures, Paramount Pictures Corporation, Sony Pictures Entertainment Inc., Twentieth Century Fox Film Corporation, Universal City Studios LLC and Warner Bros. Entertainment Inc.

## SOUTH AMERICA LAUNCHES REGION'S FIRST CLIMATE CHANGE THINK-TANK

The first climate change think-tank in South America launched in Montevideo, Uruguay, in March 2013, reports Daniela Hirschfeld in SciDev.Net. The Regional Center for Climate Change and Decision-Making, a joint initiative by the Panama-based Avina Foundation (which promotes sustainable development in the region) and the United Nations Educational, Scientific and Cultural Organization (UNESCO), aims to help policymakers design tools tailored to local needs.

The Center's programs will be implemented through a partnership program involving 10 universities and academic foundations from Argentina, Brazil, Chile, Paraguay and Uruguay. The first training event will take place in Uruguay in October 2013 and will provide an opportunity for decision-makers from various sectors and countries to discuss the latest trends in and knowledge about decision-making and climate change. A number of national and regional training courses tailored to specific local needs and designed to help put the latest development concepts and science into practice will then be rolled out in early 2014, according to Denise Gorfinkiel, Officer for Climate Change at the UNESCO Regional Office for Latin America and the Caribbean.

The initiative promises to generate "a critical mass of decision-makers who incorporate the complexity of climate change in their everyday decisions and develop new management tools," notes Ramiro Fernández, Energy and Climate Change Director for Latin America at the Avina Foundation.

## FIRST REVENUE GROWTH IN 13 YEARS FOR RECORDED MUSIC WORLDWIDE

The Recording Industry in Numbers report published by the International Federation of the Phonographic Industry (IFPI) offers insights into key trends in the recorded music market worldwide. The 2013 edition, released in April, reveals the increasing role of subscription services and growth in global recorded music trade revenue in 2012, driven in large part by growth of emerging markets. Key highlights of the report ([www.ifpi.org/content/section\\_news/20130408.html](http://www.ifpi.org/content/section_news/20130408.html)) include:

- Growth of 0.2 percent in global recorded music trade revenue in 2012 – the first year of growth since 1999;
- The US remains the world's largest music market;
- Digital channels account for 35 percent of industry trade revenue;
- Physical sales represent 57 percent of record companies' income;
- Rapid growth in the use of music subscription services which, together with ad-supported streaming services, account for 20 percent of digital revenue globally and some 31 percent of all digital music revenue in Europe;
- Growth of emerging markets is supporting the industry's recovery, with Brazil, India and Mexico witnessing growth rates, since 2008, of 24 percent, 42 percent and 17 percent, respectively;
- Demand for albums remains robust, with this format accounting for 56 percent of recorded music sales value;
- Revenue from music licensing is on the rise. Performance rights revenue (from broadcasts and public performances) grew faster than in any other sector in the recording industry in 2012, accounting for 6 percent of recorded music revenue, which rose to US\$943 million in 2012, an increase of 9.4 percent.



## CHINESE PHARMA JOINS RANKS TO BATTLE FAKE DRUGS IN AFRICA

Guilin Pharmaceuticals, the world's first producer of the World Health Organization (WHO)-prequalified antimalarial drug artesunate, has become the first Chinese company to adopt an sms-based drug verification system, allowing Nigerian consumers and patients to confirm the authenticity of the antimalarial treatments they purchase. The company recently joined the mPedigree Network, which brings together Africa's major telecom operators and leading pharmaceutical industry associations and companies.

The mPedigree Network is designed "to empower African patients and consumers to protect themselves from the fatal effects of pharmaceutical counterfeiting, which kills nearly a million people a year and maims countless more, in vulnerable parts of the world," the Network's website notes. mPedigree ([www.mpedigree.net](http://www.mpedigree.net) and [www.goldkeys.org](http://www.goldkeys.org)) is a free and rapid means for customers to verify the authenticity of the drugs they purchase at the point of sale using a mobile phone. Purchasers scratch the drug packages they buy to reveal an identification code which they then send via text message to a toll-free number for an almost instantaneous response as to the legitimacy of the product. (See "Dialing for Development: How mobile phones are transforming the lives of millions," WIPO Magazine, Issue 5, 2010 – [www.wipo.int/wipo\\_magazine/en/2010/05/article\\_0002.html](http://www.wipo.int/wipo_magazine/en/2010/05/article_0002.html)).

The service is expected eventually to expand across Africa. Bright Simons, founder of the mPedigree Network, told WIPO Magazine, "As has been the trend with trade in virtually all items, China has emerged as a major partner of Africa. Pharmaceuticals have been no different. Therefore, without the active participation of China in a program aiming to guarantee quality and authenticity in the pharmaceutical supply chain in Africa, there is seriously little chance of a comprehensive response emerging to the wanton infringement of intellectual property and, more importantly, patient rights on the continent. The entry of Guilin, and more recently Watson Global Pharma, into the mPedigree program consequently marks a fascinating watershed in the goal of empowering all Africans to insist on quality and authenticity."





For more information contact WIPO at  
[www.wipo.int](http://www.wipo.int)

34, chemin des Colombettes  
P.O. Box 18  
CH-1211 Geneva 20  
Switzerland

Telephone:  
+4122 338 91 11

Fax:  
+4122 733 54 28

**WIPO Magazine** is published bimonthly and distributed free of charge by the World Intellectual Property Organization (WIPO), Geneva, Switzerland. It is intended to help broaden public understanding of intellectual property and of WIPO's work, and is not an official document of WIPO. Views expressed in articles and letters by external contributors do not necessarily reflect those of WIPO.

For comments or questions, contact The Editor at [WipoMagazine@wipo.int](mailto:WipoMagazine@wipo.int). To order a print version of the WIPO Magazine, contact [publications.mail@wipo.int](mailto:publications.mail@wipo.int).

Copyright ©2013 World Intellectual Property Organization

All rights reserved. Articles contained herein may be reproduced for educational purposes. No part may, however, be reproduced for commercial purposes without the express written consent of the WIPO Communications Division at the above address.