



WORLD
INTELLECTUAL
PROPERTY
ORGANIZATION

WIPO MAGAZINE

GENEVA - JUNE 2007 - No.3

2

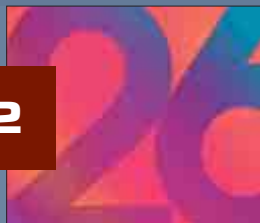

WORLD IP DAY ROUND UP

4



COPYRIGHT, CREATIVITY AND CINEMA

20

AMERICA'S CUP Dispute Resolution



Geographical Indications

International Symposium in Beijing

June 26-28

WIPO and the State Administration for Industry and Commerce (SAIC), China, will jointly host the biennial International Symposium on Geographical Indications (GIs) from June 26 to 28, 2007, at the Beijing International Hotel, Beijing, China.

The Symposium will bring together representatives of Member States' administrations, producers of GI products, and leading experts in the field to exchange experiences and views on issues relating the use and protection of GIs.

For the program and registration details, see
www.wipo.int/meetings/en/details.jsp?meeting_id=13243

WIPO contact: Ms. Marianella Di Candia at marianella.dicandia@wipo.int
SAIC contact: Mr. Chen Yongsheng at waiban.sbj@saic.gov.cn

WIPO MAGAZINE ISSUE 2007/3

Editorial team

John Tarpey
Elizabeth March
Sylvie Castonguay

WIPO staff contributors

Marcus Höpperger – [Industrial Design Symposium in Argentina](#)
Dina Leytes – [America's Cup: WIPO Provides Online Dispute Resolution Facility](#)

Acknowledgements

Carole Croella (WIPO Copyright Law Division);
Simon Ouedraogo (WIPO's Africa Bureau);
Jean-François Arrou-Vignod, and Nicholas Hopkins (WIPO Film, Multimedia and Internet Section) – [Inside the Industry – Madu Chikwendu](#)
Yo Takagi, Lesley Sherwood (WIPO Secretariat) – [IP Revolution – How Japan Formulated a National IP Strategy](#)

Cover photography

©Ivo Rovira/Alinghi

Graphic design

Sheyda Navab

CONTENTS

- 2 **WORLD INTELLECTUAL PROPERTY DAY**
- 4 CAMERA, ACTION, COPYRIGHT
- 6 MAKING MOVIES: CLOSE UP ON **BOBBY BEDI**, INDIA
- 8 THE **NOLLYWOOD** PHENOMENON
- 10 HOUNDING OUT **PIRACY**: OPERATION DOUBLE TROUBLE
- 11 IP RIGHTS AND ECONOMIC DEVELOPMENT:
AN **HISTORICAL PERSPECTIVE**
- 14 **COUNTRY FOCUS**
IP REVOLUTION - HOW **JAPAN** FORMULATED A
NATIONAL IP STRATEGY
- 18 INDUSTRIAL DESIGN SYMPOSIUM IN **ARGENTINA**
- 20 **AMERICA'S CUP**: WIPO PROVIDES ONLINE DISPUTE
RESOLUTION FACILITY
- 22 **COMMITTEE MEETINGS**
SCT: New Types of Marks, Trademark Opposition
Procedures and Industrial Designs
- 23 **WIPO AWARDS**
- 24 **LETTERS** AND COMMENT
- 26 **IN THE NEWS**
- 28 **CALENDAR** OF MEETINGS
- NEW **PRODUCTS**

WORLD INTELLECTUAL PROPERTY DAY

"Encouraging Creativity" was the theme of the of seventh World Intellectual Property Day, celebrated on April 26, 2007. For many people, the connection between intellectual property (IP) and creativity is far from obvious. As WIPO Director General Kamil Idris said in his IP Day message, the word creativity conjures a world of artists and music makers, of poets and problem solvers, whereas IP summons images of lawyers and courtrooms. But it is the IP system that sustains those creators. Member States and organizations around the world joined WIPO in celebrating this connection in different ways.

At WIPO's headquarters, participants from Africa, Asia, Latin America and Europe took part in an animated discussion on "Making IP Work for Development," hosted by the International Chamber of Commerce. Moderated by the Philippine Ambassador Enrique Manalo and the Brazilian Vice-Chair of the ICC Commission on IP, Mr. Peter Siemsen, the outcome of the discussions will provide some of the business input for the next WIPO Development Agenda meeting.

Reaching out to young people

The Hellenic Copyright Organization (Greece) staged a play about copyright written for children. For the older audience, there was a photography exhibition, Greek and jazz music concerts, and talks about copyright, patents and trademarks. The Greek Industrial Property Organization also focused on young people with an open day at its premises, including an educational program and creativity competition for children.

A group of 15 and 16 year-old students in Portugal performed humorous sketches about the protection of IP and the fight against counterfeiting, entitled "Stand up IP." Over 1,000 students attended the event at Lisbon University. The filmed sketches will

form the basis of an awareness campaign in high schools across Portugal.

Belarus announced the results of two competitions for students and graduates: the first aimed to identify students with the skills required to join the IP office's human resources; the second identified outstanding inventors and creators among science, engineering and industrial design students.

Singapore's IP office launched a year-long campaign with the aim of changing the attitudes of young people toward downloading music illegally and buying pirated CDs. A survey conducted among young people earlier in the year revealed that though 80 percent knew it was wrong to illegally download music from the Internet, 42 percent still felt unconcerned with the consequences of infringement. Liew Woon Yin, Director General of the office, explained that the campaign would include a message to parents that when their children download material from the Internet, they might inadvertently be infecting home computers with viruses.

Hong Kong, SAR China, launched the School Tour Program 2007 with the support of a famous young pop singer, using themes such as "Respect Originality,"

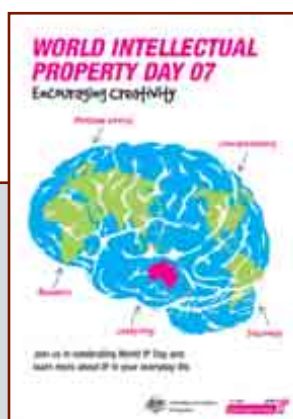

Australia



Ecuador



Greece



New Zealand

“Respect IP,” and “Say No to Illegal Downloading.” Students and professionals working in the arts shared their experiences of using the IP system. The tour will visit 50 secondary schools before the end of the year.

Paraguay launched an outreach program for young people, using the comic books jointly developed by WIPO/INDECOPI. Workshops in schools aim to help students recognize the different aspects of IP in their daily lives. The **Latvian** Patent Office presented the Latvian language version of the WIPO publication “Learn from the Past, Create the Future: Inventions and Patents” to schools across the country.

Crossing borders

An “Innovation Parliament” with participants from **Finland** and **Russia** discussed the theme “Innovation Crossing Borders.” The parliament held two plenary sessions in Lappeenranta, Eastern Finland, which shares a border with Russia, and made recommendations to increase Finland’s competitiveness. The **Italian** Patent and Trademark Office (UIBM), in cooperation with the **European** Office for Harmonization of the Internal Market (OHIM), organized an international seminar on “Community Trademarks and Design: Protection and Defense Strategies” at the *Palazzo Ducale* in Venice.

World IP Day also brought together those who question the system. Various blogs debated the validity of the patent system. Others tackled issues of copyright and the public domain, such as in discussions organized by the CopyNight group on the topic, “Encouraging Creativity: Are We?”

Pakistan used World IP Day to announce the full integration of all IP-related government administrations into one office, called IPO Pakistan, which will handle patents, trademarks, plant breeder’s rights and copyright. These activities were previously handled by three separate ministries.

In newspapers and on air

Media coverage in **Cote d’Ivoire**, included a live debate with short video clips on the weekly television program *Ça m’intéresse* (That’s interesting!). An editorial in the **Senegalese** press called for an accelerated reform of IP structures in the country, in order to leverage the creative and intellectual talents of its people and the quality of its produce. **Kuwait** organized a television broadcast and an award ceremony for a national inventors and young short story writers. **Australia’s** popular TV show, *The New Inventors*, joined forces with the IP Australia office for a World IP Day Live Forum, offering viewers the chance to put IP-related questions to a panel of experts.

Week-long celebrations in **Jamaica** included the publication of a special newspaper supplement publicizing the activities of the IP office and explaining the various tools of the IP system. Extracts from the WIPO/INDECOPI comic books were included for young readers. **Spain** intensified its *Contra la Pirateria, defiende tu cultura* (Fight piracy, defend your culture) campaign, airing the message on radio, television and in the press, and displaying it on banners in Madrid’s busy shopping district and on the façade of the Ministry building.



In the Kingdom of **Bahrain**, a series of newspaper articles on different fields of industrial property was followed by a radio discussion of the topic, “Are you buying original or fake goods?” The IP Directorate celebrated World IP Day in Bahrain’s most popular shopping mall to raise public awareness by answering questions and by distributing brochures and souvenirs.

Distribution of WIPO comics in Bahrain shopping mall.



Italy



Nicaragua



Portugal



Romania



Students from local schools performed jazz and exhibited their creative works to members of the U.S. Congress and leaders from business, government, and international organizations, including Secretary of Commerce Carlos M. Gutierrez and Congresswoman Diane Watson (above), at an event sponsored by WIPO and the George Washington University Law School's Creative and Innovative Economy Center.



The public destruction of over 80,000 pirate DVDs, CDs and tapes by the Romanian Copyright Office attracted much media attention.

The newly created Zambia Police Intellectual Property Unit, accompanied by the police force's brass band, did a one kilometer march through the center of Lusaka to the Freedom Statue, carrying a banner with their modified "enforcement" mission statement.

From the United Kingdom reports poured in from both public and private entities organizing events to mark the day. And the newspaper coverage they received was impressive. The recently renamed UK Intellectual Property Office published the results of a survey, designed to gauge the level of IP awareness in businesses of all sizes and sectors of industry. Results revealed that small businesses are still missing out on income generation potential from innovation because a lack of awareness of their IP rights. Some law firms, such as Pinsent Masons, responded to this gap by offering free legal advice for the day to entrepreneurs on copyright, trade marks, patents or designs.

The need to increase understanding of IP was a recurring theme on IP Day. While World IP Day offers an opportunity to make a splash once a year, sustained, well focused IP outreach needs to be an ongoing activity all year round.

Further information

- For more IP Day activity reports, and a selection of promotional material see the 2007 IP Day website at www.wipo.int/about-ip/en/world_ip/2007/index.html
- For the WIPO Guides on planning an outreach campaign, see: www.wipo.int/ip-outreach/en/guides/



Spain

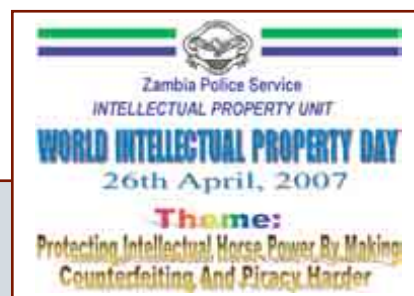

Zambia

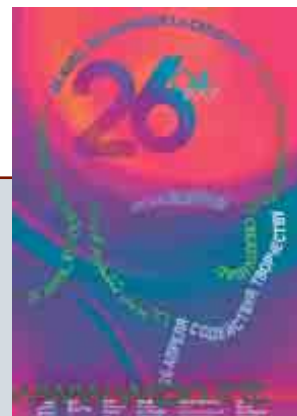

WIPO

CAMERA, ACTION, COPYRIGHT

“It is not only about economics, it is about dreaming.”

Dr. Ajay Dua, Indian Ministry of Commerce and Industry.

As stars and hot-shot directors set the paparazzi spinning this month at the 60th Cannes Film Festival, the film industry appears as the very essence of glamour. The same could never be said of copyright. But beneath the glitz and the box office hits, a solid foundation of copyright and related rights is what allows movie-makers to earn a return on their investment, and enables the film industry to thrive.

And thrive it does. In India, the Rs. 85 billion (US\$2 billion) film industry is projected to grow at a compound annual rate of 16 percent for the next 5 years.¹ In the U.S., the motion picture and television industry provided jobs for more than 1.3 million people in 2005.² South Korean blockbusters with ticket sales of over 10 million³ have fueled the explosion of “Kim Chic” popular culture in the region. Film production in Morocco and Iran is flourishing. The list goes on...

Films are highly collaborative works. In developing a film from original concept to final cut a filmmaker invests in the works of numerous other creators – scriptwriters, song writers and score composers, computer animation artists, set and costume designers – not to mention performers. Contractual agreements which define the ownership and use of the multiple creative inputs are necessary to protect the interests of all concerned, to avoid costly disputes, to facilitate financing and distribution, and to defend against illegal copying.

Threat

There lies the rub. Dizzying advances in digital technology are proving both boon and bane to the film industry. While video did not kill the movies, as the film studios of the 1980s feared it would, (see *Fifty Years of the Video Cassette Recorder*, WIPO Magazine 2006/06), the massive scale of digital piracy today is widely perceived as the greatest single threat to those whose livelihoods depend on the industry. Technical protection mechanisms, such as digital rights management (DRM), have not proven a panacea, and industry groups in developed and developing countries alike are petitioning for tightened copyright legislation and for more effective enforcement mechanisms.

One novel approach to enforcement, which the Malaysian government is pursuing in cooperation with the Motion Picture Association, is featured in our article, *Hounding Out Piracy* (page 10). Meanwhile, governments and industry associations continue to develop publicity campaigns, deploying different sorts of messages aimed at deterring consumers from buying pirated DVDs. The latest, multi-million pound anti-piracy initiative by the Industry Trust for IP Awareness Trust in the U.K., where almost one in three people are said to watch illegal content, marks a departure from previous messages that concentrated on enforcement and the

criminal nature of those involved in piracy. Instead, the campaign aims to stigmatize the consumption of pirated goods by poking fun at “Knock-off Nigels” – the kind of individuals who avoid buying a round of drinks at the pub, give their girlfriend a fake watch, and buy pirate DVDs.

Stakeholders speak

WIPO’s own public outreach activities in this area seek to let the creators and stakeholders speak for themselves. In the interviews that follow, an Indian film producer and a leading figure in the Nigerian film industry reinforce the message that, while IP helps encourage creativity, inadequate enforcement only discourages creators and undermines the economic potential of creative industries.

Related articles from previous issues:

- *Putting Africa on the Animation Map: The Story of Pictoan, Senegal*
September/October 2005
- *Shakespeare Meets Bollywood in Delhi’s IP Drama*
November/December 2005
- *Argentina’s Flourishing Film Industry*
May/June 2005



1. FICCI – PricewaterhouseCoopers Annual Report on Indian Entertainment and Media Industry 2007
2. Motion Picture Association of America 2006 Report, *The Economic Impact of the Motion Picture and Television Production Industry on the United States*
3. Korean Film Council, Summary of the Korean film industry in 2006

MAKING MOVIES

Close Up on Bobby Bedi, India



Biodata

Born: 1956, New Delhi, India

Education: Masters Degree in Management, University of Bombay, BA in Economics, University of Delhi

Professional Activities: Film producer; Founder and Managing Director of Kaleidoscope Entertainment in Mumbai; Advisor to the Industrial Development Bank of India and India's

Minister of Information and Broadcasting; Member of the Governing Council of the Film & Television Institute of India; Founder of the "School of Convergence," India's first post-graduate school teaching content creation and management

Film achievements: Produced ten feature films, including *Bandit Queen*, *Fire*, *Saathiya*, *Maqbool*, *American Daylight*, *The Rising*; received two National Awards from President of India

Bollywood summons up instant images among movie fans: music, dance, Indian traditions and brilliantly colored costumes. With some four billion tickets sold annually – one billion more than Hollywood – India's film industry is the largest in the world, enjoying immense popularity from Southeast Asia to Africa, from Eastern Europe to the Middle East.

Among the prolific creators in the Indian film industry is Bobby Bedi, a film producer from Mumbai.* His film, *Bandit Queen*, won critical acclaim at the Cannes Festival in 1994. The film broke the mold of mainstream Bollywood movies, and generated a fair share of controversy, portraying the plight of Phoolan Devi, a real life character who fought against the exploitation of India's poorest. In 2003, he released *The Rising*, a historical epic on the rebellion of native soldiers serving under British rule in the late 19th Century. Bobby Bedi is also a strong advocate for the recognition and enforcement of intellectual property rights, as he explains in this interview with WIPO Magazine.

Your initial training was in the field of finance. What first attracted you to the film industry?

I had worked with Philips and Sony after my MBA so there had been a fair amount of exposure to the entertainment sector – albeit from the hardware side. Film is an industry where order needs to exist side by side with chaos – and the whole idea of bringing order in the lives of a bunch of "mad" people, and yet be able to create good stuff, was a challenge.

What highs and lows have you experienced as a filmmaker?

The success, critical or financial, can be a great high. Sometimes the two go off together. That is easily the best high and we experienced it with *Bandit Queen* and *Saathiya*. The lows are of course deep, long and frequent. As a filmmaker, one has to be "predictably" uncertain about one's next act. It can be great or bad, but irrespective of the artistic quality, it can be rejected by the audience. That is the worst low – failure hitting you in one night after 15 months of work.

Can you tell us something about the creative process in producing a movie like the *Bandit Queen*?

In the *Bandit Queen*, we were very clear about the script. Farrukh Dhondy [the screenwriter] and I had worked on all the material to extract the story and script and to make sure the film was accurately captured in that script and vice versa.

The real treat was the magic that [the director] Shekhar Kapur created by converting a good hard hitting script into a "lethal blow in the solar plexus of the world." It is when you see the film that you realize how many people contribute to converting an idea into a movie. And that it is the perfect harmony of these creative contributions – script, camera, sound, art, performances and direction – that creates a great film. Every time someone contributes to a film, it evolves. It really is in itself a gratifying process.

You have spoken out as a strong advocate of IP. What does IP mean to you as a filmmaker?

It is unreasonable to suggest that, just because my property is not made of metal, cement or fabric, but is of a creative kind, it is not worthy of being protected in the same way. Theft of IP is theft, and should be universally condemned.

* Mumbai was previously called Bombay, from which came the play on words with Hollywood to create the term Bollywood – used as an identifier of the Indian film industry as a whole.

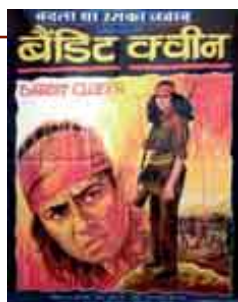

Bandit Queen



The Rising



Illustration of the Battle of Kurukshetra from the Mahabharata epic.



Electric Moon

The abuse of IP prevents the receiving of credit where credit is due, and cash where cash is due. How important is IP to me? Its main manifest is in piracy, which accounts for over 50 percent of the money I never make. It accounts for the money that criminals and terrorists use against me.

Tell us about the *Mahabharata* project?

The *Mahabharata* is an ancient Indian epic with over 74,000 verses. There is no conflict or resolution known to mankind that is not reflected in the verses of the *Mahabharata*, no known personality or character trait that is missing, no relationship unexplored and no lesson untaught.

The project will include 150 one-hour long TV episodes, three films, mobile and PC gaming, picture books, animation, [toy] action figures and hopefully a live [theme park] experience. Our *Mahabharata* is a 360 degree vision that tries to engage with world audiences through all of the above.

This is the communication age. We have communication criss-crossing around us as written words, painted or projected images, sounds, data signals, broadband, etc. Most of it is information, some of it is education and some entertainment. In recent years, I have begun to firmly believe that *all* communication can and should follow a fixed order for it to be effective:

- Engage
- Entertain
- Inform
- Educate

The *Mahabharata* is conceived to do all of the above and in that order.

The mere scope of the project reflects why IP is important to me. If my rights as a creator are not respected and enforced, it will be impossible to realize this formidable project.

India has the largest film industry in the world in terms of volume, but is frequently cited as generating less than 1 percent of global film revenues. What is the problem?

There are various reasons: purchasing power parity, low per capita income, cultural and linguistic diversity, taxes, lack of development – read this as making films that would be rejected due to problems encountered in the development stage – and a country that has been poor for too long. And finally – piracy.

What do you see as the reasons for film piracy in India?

Neither the public, nor the Government and law enforcing agencies genuinely believe this to be theft. It's not lack of the law; it's the frivolous way in which our law enforcers view IP theft.

What more should be done to promote the exploitation of IP in India's film industry?

We need to be taught proper rights management and rights monetization.

Do you have a message for aspiring filmmakers?

Make movies. Make good movies.

For more, read *Utopia*, Bobby Bedi's address to the WIPO International Seminar on Intellectual Property and Development (2005): www.fiapf.org/pdf/cannes05/WIPODev_BediSpeech.pdf

THE NOLLYWOOD PHENOMENON



©Almee Corrigan

"In Nollywood we don't count the walls, we learn how to climb them." – Director Bond Emerua in "This is Nollywood."

Nigeria's burgeoning film industry, now considered the world's third largest after Hollywood and India's "Bollywood," is in a league of its own.

Dubbed Nollywood, the industry is characterized by its prolific output of ultra-low budget films, shot with digital cameras, produced straight to video/DVD format, and sold directly to customers for two or three dollars. For 15 years, largely ignoring the external cinema world, Nollywood has fuelled an insatiable appetite in Africa's most populous country for homegrown films made by Nigerians, about Nigerians. The market is expanding as the popularity of the films spreads across Africa, supplying the needs of local television stations and audiences for low-cost entertainment content.

It is an industry made possible by affordable digital technology, and driven by the ingenuity, resourcefulness and keen business sense of Nigeria's people. Production time for an average video-film is often less than two months, from casting through to distribution. Films are shot under conditions that professionals elsewhere would consider impossible, with budgets as little as US\$15,000. A film can expect to sell about 50,000 copies, or several hundred thousand if it is a hit. The returns on investment attract ever more hopefuls into the industry, which is now a major employer in parts of the country.

Chris Obi-Rapu's *Living in Bondage*, released in 1992, is widely credited with having sparked the Nollywood revival out of the ashes of the country's moribund feature film industry. The film's cheap video format, and the bold narration of family melodrama laced with black magic, made it a smash hit, and provided the hugely successful formula for those which followed.

Grass-roots revolution

The Nollywood phenomenon has begun to catch the eye of the world's media and cinema pundits: "The raw energy of the movies – and the flurry in which they are filmed and sold – is a kind of grass-roots creative revolution on a continent where stories have been told for generations but rarely committed to film," wrote Neely Tucker in the *Washington Post*, inspired by the rare screening in a U.S. movie theatre of a Nigerian film, *Behind Closed Doors*. The industry has itself become the subject of films. *This is Nollywood*, a film by Franco Sacchi and Robert Caputo, follows director Bond Emerua's quest to shoot a feature length action film in nine days, armed with just a digital camera and two lights.

"We tell our own stories"

Yet the films themselves remain largely unknown to cinema audiences outside Africa. Among a handful which have become more widely known, is *Osuofia in London*, starring comic actor Nkem Owoh, which satirizes British and Nigerian cultural differences. *Ezra*, from director Newton Aduaka, won top prize at the Pan-African Festival of Cinema and Television (FESPACO) in Burkina Faso this year. But few as yet pass the quality threshold for major international festivals. And the blunt portrayal of popular themes, such as religion, witchcraft, morality and revenge, makes little concession to U.S. or European tastes and expectations. "We tell our own stories," explains actress Genevieve Nnaji, who shot to superstar status in hits such as *Blood Sisters* and *What Women Want*. "That's why a lot of Africans can relate to it, and understand and laugh about it and learn lessons. So the industry does play a huge role in our lives."

Inside the Industry - Madu Chikwendu



Madu Chikwendu is working to license Nigerian content worldwide. "We know of more than 1,500 sites pirating Nigerian film products."

Madu Chikwendu is a leading figure in the Nigerian film industry. A film-maker and producer, he is president of the Movie Producers Association of Nigeria and the regional representative for West Africa of the Pan-African Federation of Filmmakers (FEPACI). In an interview in March with a visiting team of WIPO copyright and outreach experts, he described how the industry functions, and the issues with which it is grappling. The following extracts are based on his account.

"The Nollywood model is easy to understand. It is a system of production based on the use of digital video equipment. The movies go straight to DVD format for sales and rental. It is highly mobile, highly efficient. The system of distribution is also very informal. The DVDs are replicated in their thousands, and then distributed every two weeks on a Monday in big wholesale markets in Lagos, Kanu and Onitsha. There are about 90 new movies released every month – over 1,000 each year."

Not one Nollywood

"There is a misconception about Nollywood. It is not actually one film industry but four. The part that the world knows is the English language

industry, which has its production center in Lagos and is dominated by people from the south east of Nigeria. While the language used is English, the stories in these films reflect the ideology of the Igbo people of the region.

"The second industry is much, much older, and consists of the indigenous Yoruba language movies. This can be traced back to the Nigerian feature film industry of the 60's and 70's, up until the economic downturn meant that people could no longer afford to produce feature films anymore and started making videos instead.

"Then you have another industry in the North of the country, by the Hausa population. That is different again. It has a lot of Islamic influences, and is also influenced by the style of Bollywood films, with lots of song and dance. There are also pockets of smaller production, like in the south around the Niger Delta. These are also indigenous, mainly made in the Edo language.

"Each of these has its own associations for the industry professionals, so it is a bit polarized on ethnic lines, which is regrettable. But there some meeting points, such as the Motion Picture Council of Nigeria, in which all the different areas are represented for the purpose of regulating the industry and lobbying the government."

Transnational piracy

"Nigerian films are being pirated all over the place and no-one seems to care. Perhaps some of the other countries in Africa which don't produce their own movies don't feel they have a stake

in protecting intellectual property. They think that the Nigerian industry is king and doesn't need the money. We have an obligation to promote centers of production in different parts of Africa, which will also be a means of protecting our own intellectual property.

"Within Nigeria, illegal rentals are the biggest form of piracy. There are 40,000 video clubs, which just buy the DVDs and rent them out without paying anything to [the copyright owners]. We petitioned the government, and the Copyright Commission is now setting up a system of royalty payments.

"But the problem goes beyond the Copyright Commission. Some of the major forms of piracy we experience are not local. There is all the illegal broadcasting of Nigerian films by TV stations in other African countries, which just buy a copy of a movie from a shop then play it on their stations. Then there is massive piracy of our movies on the Internet. We know of more than 1,500 sites pirating Nigerian products, including sites domiciled in the U.S., U.K. and Europe, and in developing countries which have mechanisms for enforcement, but are not using them. In the U.S. they are always talking about piracy of their films. But no-one talks about piracy of Nigerian films. We want the world to begin to understand the wider implications. We are trying to assess the level of loss.

"Being a creator in Africa can be so frustrating. That is why I have turned more towards the distribution side. But piracy will not kill our industry. Nigerians are too resolute, too strong to let that happen. Now we are concentrating on trying to license Nollywood content across the world." ■

HOUNDING OUT PIRACY

Operation Double Trouble



Flo (right) and Lucky, trained to sniff out hidden consignments of pirated DVDs. In 10 minutes they can search a container which would take their human counterparts all day.

Malaysia's new champions in the fight against film and music piracy are only three years old, but are already making their mark. Meet Flo and Lucky.

The two black Labradors, believed to be the first dogs ever trained to detect polycarbonate and other chemicals used in the manufacture of optical discs, are being deployed by Malaysian enforcement officers at border crossings and cargo storage centers to uncover consignments of pirated CDs and DVDs. While they cannot distinguish by scent between a legitimate disc and a pirate copy, the dogs are proving highly successful at sniffing out discs in hidden compartments or unregistered shipments.

Nick-named Operation Double Trouble, Malaysia's ground-breaking project is backed by the Motion Pictures Association (MPA), which groups six of the big Hollywood movie companies. The MPA has invested US\$17,000 in the dogs, including eight months training in Northern Ireland with a handler who usually teaches sniffer dogs to find bombs.

Seizing headlines Syndicates snap back

The duo has already gained celebrity status. At a press briefing in March at Malaysia's biggest air cargo hangar, the dogs showed off their skills to assembled journalists, winning wide coverage in the international media. The dogs continued to make headlines over the next few weeks, as they led raids in Johor Bahru and in Kuala Lumpur, resulting in 14 arrests and the seizure of 1.3 million pirated DVDs.

Flo and Lucky began an initial month long trial in March to evaluate the effectiveness of introducing dog units into Malaysia's enforcement divisions. "It's cost-effective, and in terms of time, it's very effective too," Malaysia's Minister of Domestic Trade, Shafie Apdal, commented, as he described how the dogs took a mere ten minutes to check the contents of containers which enforcement officers would need all day to search.

The MPA's senior vice president and Asia-Pacific regional director, Mike Ellis, highlighted the discovery in recent raids of child pornography alongside pirated movies. "Piracy is frequently linked to other insidious activities," he said. "Consumers should be aware that their purchases of pirated movies fund the ongoing illegal operations of the movie pirates, who may also be profiting from the distribution of child pornography."

Local crime syndicates lost little time in seeking to neutralize the crack canine team. The Malaysian government reported threats that syndicate bosses had put a RM 100,000 (US\$29,000) bounty on the dogs' heads. Flo and Lucky are now kept closely guarded.

Crime groups have failed to outwit the dogs through ploys such as spraying pirate DVDs with chemicals or wrapping them in soap parcels. One illicit stash uncovered by the dogs in April was packed with charcoal, apparently in the belief that this would absorb the scent of the polycarbonate.

Following the success of the initial trial period, the Malaysian government has decided to extend Operation Double Trouble indefinitely. Neighboring countries are also watching with interest. Lucky and Flo have already made a flying visit to the Philippines, where they helped law enforcement officials seize an estimated 300,000 pirated DVDs from three malls in Manila notorious for the sale of pirated movies and music.

Says the dogs' trainer: "This is nothing more than a big game to them. They are just doing the job so that they can get their reward." And what is their reward when they find the discs? "They get to play with a chewed tennis ball."

IP RIGHTS AND ECONOMIC DEVELOPMENT

An Historical Perspective



ZORINA KHAN, Associate Professor of Economics at Bowdoin College, U.S., is a member of the National Bureau of Economic Research and was a contributor to the U.K. Commission on Intellectual Property Rights. She won the 2006 Economic History Association biennial prize for an Outstanding Book on North American Economic History. Her book, “The Democratization of Invention: Patents and Copyrights in American Economic Development, 1790-1920,” contrasts the structures of the intellectual property (IP) systems in Europe and the United States during the 19th century, and analyzes the effect on industrialization and economic development in these regions.

In the following extracts from a recent interview with WIPO Magazine, Professor Khan shares some of her conclusions and draws analogies with the situation in developing countries today.

Why the design of patent systems matters

“The framers of early American patent policy were convinced that individuals responded to incentives, and so carefully calibrated the system to promote inventive activity. This was evident at the highest levels (e.g. the inclusion of an IP clause in the U.S. Constitution) and the most detailed provisions (e.g. to enable patent applicants in rural areas to mail in their applications without having to pay postage).

Historically, the U.S. took the lead in offering strong protection for patented inventions, and in facilitating widespread markets in patent rights. Patents were regarded as the “dearest and most valuable rights which society acknowledges,”¹ and patent holders could appeal to the Supreme Court to plead their causes. Patent holders were never regarded as monopolists, since their contributions to new products and productivity benefited the public.

European countries, on the other hand, tended to regard patent rights as monopolistic. Patent rights were restricted – by the courts and the state – to protect vested interests and existing jobs. Fees were kept high



Inventive activity flourished under the U.S. policy of facilitating access to patent rights for the common man.

to create revenue for employees and the government. Internationally, the U.S. took the lead in encouraging other countries to strengthen their patent laws in order to benefit globally-competitive American patent holders.

Comparisons between Europe and the U.S. suggest that their differing approach to IP affected the direction, and possibly the rate, of their inventive activity. U.S. inventors were drawn from a wider spectrum of the population than in Europe, and inventiveness was far more broadly distributed across all industries. Markets in patent rights and patented inventions flourished, and this market-orientation was especially beneficial

to patent holders who did not have the financial resources to exploit their patents.

These observations are consistent with the patterns of productivity and economic growth. U.S. productivity gains were evident in all sectors, even labor-intensive industries, and growth paths were balanced. In Britain, by contrast, patented inventions tended to be capital-intensive, and clustered in a few industries such as steel and textiles; it is likely not coincidental that British productivity was lower, limited to these few industries, and growth was unbalanced.

1. U.S. Supreme Court, ex Parte Wood & Brundage, 22 U.S. 603, 1824



The historical evidence therefore strongly suggests that the design of patent systems matters. However, patent systems are also embedded in a set of related institutions, such as the legal system, markets for technology, and educational organizations. When this network is flexible and mutually reinforcing, the prospects for technological innovation are heightened. But if other institutions are not responsive and enabling, even a well-designed patent system can be ineffective. Thus, in today's developing countries, IP policies should not be considered independently of this network of related institutions."

By Comte Stanislaw Julian Ostrog-dit-Walery (1830-1890)

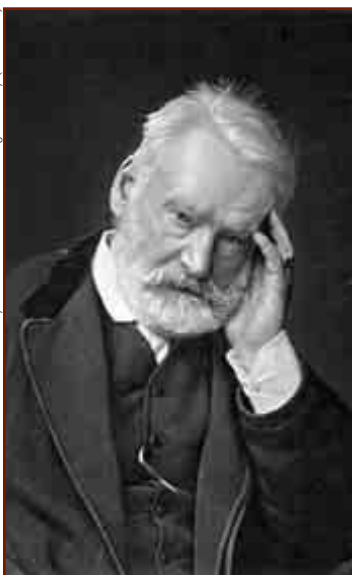

Championed by writers such as Victor Hugo, France took the lead in promoting international copyright harmonization.

How copyright went the other way

"American exceptionalism was also evident in the area of copyrights, but in the opposite direction to patents. The U.S. emphasized the importance of mass literacy and public education, and limited protection when a conflict might exist between learning and copyright. For instance, the U.S. fair use ex-

The principle of allowing ordinary people access to IP rights is still vital to achieving advances in global welfare.

emption (allowing unauthorized access to copyrighted works) was the most generous in the world. Americans not only refused to adhere to international copyright treaties long upheld by European countries, but also engaged for a century in piracy of foreign cultural products, even in the face of widespread condemnation. My research suggests that such copyright piracy benefited the U.S. initially when the country was a net debtor. But once the balance of trade moved in its favor, America had an incentive to adopt stronger laws to protect its authors internationally.

By contrast, European policies viewed copyright owners as inherently deserving of strong protection. The French copyright regime evolved in the direction of inalienable authors' rights, and France took the lead in promoting international harmonization in copyright laws."

How women inventors responded to incentives in IP systems

"Women in many rural and still-developing regions face attitudes that are probably very similar to those that American women confronted in the 19th century. And, just like their historical counterparts, women in today's developing countries quietly continue to make creative adjustments to their circumstances that benefit everyone in the household.

Women inventors responded to incentives that allowed them to benefit from their efforts. While a

few women did construct extremely complex inventions, such as Maria Beasley's barrel-making machine, the majority drew on the expertise they had acquired in the course of completing their household tasks. The typical woman inventor patented improvements to clothing, household appliances, cooking, or other more domestic activities. Some patents offer amusing insights into the motivations of their inventors, such as the "noiseless desk" invented by a teacher in a school for delinquent boys; or the "combination see-saw and washing-machine" which a mother invented to take advantage of the exertions of her children.

If the technical value of such inventions was quite low, that is not to say that their economic value was also low. Many of these ingenious devices were very profitable in the marketplace. As Thomas Jefferson once put it, "a smaller [invention], applicable to our daily concerns, is infinitely more valuable than the greatest which can be used only for great objects." Similarly, we should not underestimate the potential value of IP rights in encouraging women in developing countries today to make "small" improvements.

Balancing the benefits for big business and for individuals

"It is undoubtedly true that IP is produced primarily by the employees of large firms, with the rights owned by the corporations themselves. However, that is different from the claim some critics today make that ordinary people do not benefit from IP rights. Although the specific rules and standards might differ from their historical precursors, the principle of allow-

ing ordinary people access to IP rights is still vital to achieving advances in global welfare.

A great deal of research on appropriate technologies and microfinancing refutes the notion that “ordinary people” do not have the capability to improve their circumstances through their own efforts. Offering accessible property rights can be part of a decentralized strategy extending to the informal economy and to rural communities, which tend to be untouched by the large-scale urban projects that incorporate foreign technologies. Moreover, secure IP rights in patented inventions help to create tradeable assets, and this securitization disproportionately benefits ordinary individuals who do not have access to financing.

Again, I make a distinction between patents and copyrights. Knowledge, information, literacy and learning are all key determinants of prospects for growth, so I believe it is crucial for copyright doctrines to facilitate this process through liberal use of fair use exceptions and expansion of the public domain. Yet international harmonization and corporate lobbying are continuing to expand copyrights and reduce the public domain.”

Improving the IP system

“As in the 19th century, there is no shortage today of proposals regarding policies that might best promote social and economic development. A number of economists have been persuaded by alternative policy instruments such as state-sponsored awards, buy-outs and prizes. But abundant historical evidence from France and England illustrates the inefficiencies, corruption, and lack of incentives for reforms that are likely to be associated with a non-market orientation. IP systems do have disadvantages, but markets offer net benefits that cannot be replicated. So, rather than abolishing the existing IP framework, we should try to modify and improve it.

Appropriate IP institutions should enhance the incentives for residents in developing countries to create and market incremental inventions (broadly defined to include cultural goods) that have the potential to dramatically improve their standards of living. However, such incentives should be sensitive to the broader social context. Criticisms have been lev-

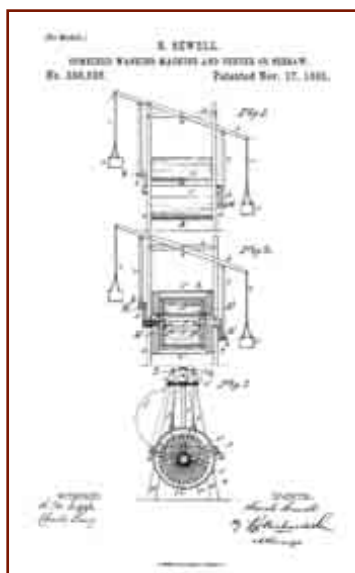

Happy children and easy laundry. Sarah Sewell's combined washing machine and see-saw addressed the preoccupations of busy housewives.

eled against some developing countries for not offering universal patent protection, such as India (which did not offer patent protection for drugs, chemicals and alloys, optical glass, or semiconductors) and Brazil (where chemicals, drugs and foodstuffs were not protected before the 1990s). Yet historically, most developed countries other than the U.S. exempted particular industries from protection. The French statute of 1791 exempted medicines from patent grants. England countered continental supremacy in chemicals by excluding patent protection for chemical products, and until recently issued compulsory licences for pharmaceuticals and food products. Germany, emu-

lated by Japan, did not issue patents for food, pharmaceutical, or chemical products. Consequently, there is ample historical precedent for a policy of discretionary grants across sectors or products in order to serve the public interest.

As for copyright laws in developing countries, I should like to see a much stronger fair use doctrine implemented, to allow free unauthorized access to certain categories of copyrighted materials. For instance, schools and universities should not have to fear copyright enforcement that has a chilling effect on learning and education. In the long run everyone benefits from such access, since the enhancement of literacy and learning can dramatically expand the future market for copyrighted goods.

History indicates that the menu of choices is much more limited for today's developing countries. The IP regimes of the 21st century are not wholly self-determined, but are constrained by the political economic parameters set largely by the advanced nations. I hope that international organizations such as WIPO can provide a more effective forum where the voices and interests of the disenfranchised populations in the global economy will be heard.

For more information see:

- Professor Khan's page on the Bowdoin college website: <http://academic.bowdoin.edu/faculty/B/bkhan/>
- The Commission for Intellectual Property Rights study papers: www.iprcommission.org/graphic/documents/study_papers.htm

IP Revolution

HOW JAPAN FORMULATED A NATIONAL IP STRATEGY



HISAMITSU ARAI played a central role in formulating and implementing the national strategy which aims to make Japan a “top intellectual property-based nation.” This article is excerpted from Mr. Arai’s latest book, *Intellectual Property Revolution*, published (in Japanese) by Kadokawa Publishing Corporation, Tokyo, in September 2006. The English text of the article was prepared by the WIPO Secretariat in consultation with the author.

It seems that not a day passes without an article about intellectual property (IP) appearing in the press somewhere in the world. This growing media coverage reflects a major shift in the driving force of international trade – from tangible property in the form of goods and products, to intangible intellectual property in the form of innovative and creative works. Nowadays, the competitiveness of a state depends to a large extent on how well it manages these intangible assets. This overview of how Japan began to revitalize its economy through innovation and creativity – and through the strategic use of the IP system to protect them – is an instructive illustration, that may be of interest to policymakers and stakeholders in other countries.

1996 An outdated system

When I took office as Commissioner of the Japan Patent Office (JPO) in 1996, the national IP system was rigid and out-dated, and the country’s IP law and policies needed reviewing in the light of a new role for IP in Japan’s new innovation policies. Urgent action was required, especially as Japan was struggling to recover from a long economic slump – the so-called “lost decade” of the 1990s.

First, the patent system had to become more user-friendly, particularly to researchers and managers of small and medium sized enterprises (SMEs). Interviews with employees at research institutes and factories indicated that the processing of patent applications by the JPO was too slow and onerous. My top priority was

therefore to accelerate the examination procedure to meet users’ needs, which were growing rapidly, in part due to fast-moving technological changes.

An additional priority was to increase the amount of damages awarded to patent owners in cases of infringement, as these were too small to discourage illegal activities. If Japan was to become an “IP-based state,” more severe penalties had to be imposed on parties willfully infringing IP rights. I felt strongly that Japanese citizens should be encouraged to create new technologies, rather than purloining existing ones. With this in mind, I proposed a major amendment to the patent law that included changes in the criteria for assessing damages for IP infringement.

2001 Landmark cases

I left government service in 2001; but in that same year, two IP cases prompted me to take action which triggered Government debate and eventually led to the launching of Japan’s national IP strategy.

The first case concerned a Japanese researcher at a U.S. university medical center who was accused of illegally taking genetic material from the center for research on Alzheimer’s disease. His contract stated that any research results belonged to the center, but the researcher had not understood the scope of this provision. This confirmed my concern about the lack of awareness about IP among Japanese researchers and companies, particularly those undertaking joint research projects.

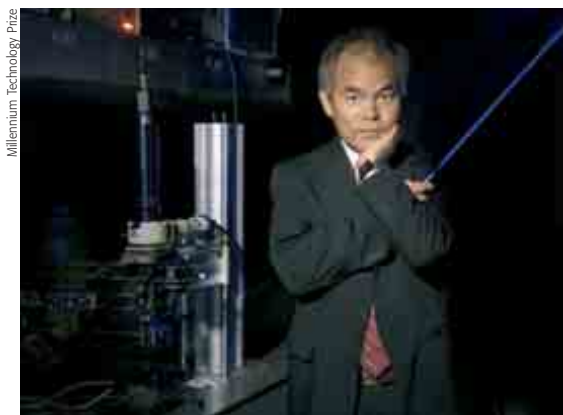

Millennium Technology Prize

Dr. Shuji Nakamura, winner of the 2006 Millennium Technology Prize, surprised the world in 1993 when he demonstrated bright-blue LEDs.

The second case was a patent lawsuit filed by an inventor, Dr. Nakamura, against his former employer, the Nichia chemical company, over his claim for “appropriate” remuneration for his contribution to the invention of a blue light-emitting diode (LED), that had excellent market potential. The Tokyo District Court ruled that the company should pay Dr. Nakamura some US\$180 million (the sum he had sought), although he could have requested half the estimated company profits on the invention (US\$1,200 million).

Industry was critical of the decision and of the way in which Dr. Nakamura’s contribution had been calculated. Under Japanese patent law, patent rights belong to researchers even if the invention is made in the course of their employment. However, a company can conclude a contract with its employees and researchers whereby patent rights are assigned and transferred to the company in return for appropriate compensation. Dr. Nakamura’s case became a test case in establishing guidelines on “appropriate” remuneration.

On appeal, the parties settled out of court in 2005 and Dr. Nakamura accepted US\$8 million in return for transferring the patent rights to Nichia. The group of lawyers assisting Dr. Nakamura noted in a statement that, first, compared with the \$200 originally proposed as remuneration for the invention, \$8 million, though much less than the value of the invention, was a significant victory; second, the case had clarified the relationship between employee and employer with regard to the employees’ inventions; third, establishing a correct evaluation of an invention should help promote research in Japan; and, finally, the new principles on evaluation and remuneration established a much-needed precedent.

Initial discussions

Concerned about the issues raised in these cases, I, together with ten like-minded people, set up a small task force, the National Forum for an Intellectual Property Strategy, in August 2001. We believed that if Japanese researchers, engineers and creators could establish a win-win relation with their employers and collaborators, innovative activity would greatly increase, resulting in strong patents that would boost both the Japanese and the world economy. Japan’s long recession at that time was blamed by many people on the financial system and banks; however, the weakness of industry and its lack of competitiveness was also responsible.¹

Under the slogan – *Intellectual property: powering Japan to the top by 2010*, the Forum published in January 2002 a list of 100 suggestions plus a ten-year action plan. The suggestions covered seven areas – universities, education, private enterprises, governments, diplomacy, legislation and the judiciary – and called for a fundamental review of policies, using a comprehensive, holistic approach. The Forum’s work began to attract the interest of some politicians.

2002 Turning point

In his annual address to the Diet (Parliament) in February 2002, the then Prime Minister Koizumi said: “Japan already possesses some of the best patents and other IP in the world. I will set as one of our national goals that the results of research activities and creative endeavors are translated into IP [rights] that are strategically protected and utilized so that we can enhance the international competitiveness of Japanese industries.” This was the first specific mention of IP in a Prime Minister’s keynote address in the history of Japan. Prime Minister Koizumi set up and chaired a new Intellectual Property Strategy Council, of which I was appointed a member, and made clear that an IP strategy was to be a key part of an overall national strategy, aimed at making Japan an IP-based nation.

An outline IP Strategy was prepared and, in November 2002, a Basic Law on Intellectual Property was enacted. The Law was intended “to promote measures for the creation, protection and exploitation of IP in a focused and planned manner.” This included clarifying the responsibilities of the State, local governments, universities, and business enterprises etc. The new Law also established the Intellectual Property Strategy Headquarters, a permanent body

1. In 2002, Japan had dropped to 27th place, its lowest ever, on the IMD global competitiveness rating (IMD 2004, p. 290)



based on the work of the Intellectual Property Strategy Council, comprising the Prime Minister as Chair, all the Cabinet Ministers as members, ten experts, and myself as Secretary-General reporting to the Prime Minister.

Vision and priorities

The first action plan, or "IP Strategic Program," approved by the IP Strategy Headquarters in July 2003, contained some 270 proposals for legislative and institutional reform. They included radical measures to

speed up patent examination; the creation of the High Court of Intellectual Property; and the reinforcement of anti-counterfeiting and piracy measures.

Japan's IP strategy is based on the premise that strategic use of IP is the only way for the country, which lacks natural resources, to maintain its position in the world economy by enhancing its competitiveness. It is also based on the belief that enhanced innovation and creativity in Japan benefits the world economy and the well being of society as a whole, including the countries of the developing world. Japan's IP promotion plan initially consisted of activities in five priority areas:

- IP creation;
- IP protection;
- IP commercial exploitation;
- promotion of creative content, particularly audiovisual works; and
- human resource development.

To invigorate the innovation cycle, the role of universities and R&D institutions were reviewed. To enable them to play a role in the commercialization of research results, particularly if funded by the government, changes were made in laws and policies, encouraging, for example, the setting up of technology licensing offices, which would assume ownership of IP rights in research results and promote licensing of the associated technologies. Some 100 such offices were established to support the new role of universities in the strategic use of IP.

Regarding patent protection, some 500 fixed-term examiners were employed to reduce the backlog in patent examination; and prior art search was outsourced. These measures aimed to reduce the period of patent examination from 26 to 11 months by 2013. The enforcement of IP rights was also strengthened by the establishment in April 2005 of the High Court of Intellectual Property to speed up IP dispute resolution by improving support from technical experts, establishing a coherent approach to the cases and centralizing the jurisdiction of IP disputes.

In the area of commercial exploitation of IP rights, amendments to the Business Trust Law in December 2004 allowed rights-holders to use their IP as collateral to raise start-up funds for new businesses. Small and medium-sized enterprises could now use their IP strategically to enhance their business opportunities.

The new Contents Promotion Law, of May 2004, was introduced to strengthen the collaboration between creators and companies involved in Japan's strong movie, animation and software game industries. IP education at university level was reinforced by including IP law courses in the curricula of more than 70 colleges and by setting up specialized IP post-graduate courses. The mid-term goal for IP education and training is that the number of trained, specialized IP professionals should increase from the current 60,000 to 120,000 within the next ten years.

Most recently, Japan's focus has shifted to the contribution it can make to the international community through sharing its knowledge and the results of innovation, as well as by addressing the global threat posed by counterfeiting and piracy. The vision from which Japan's IP strategy grew is based on the belief that innovation and creativity should be rewarded; counterfeiting and piracy are a serious threat to realizing that vision.

At every meeting of the IP Strategy Headquarters, the Prime Minister gave instructions to relevant Ministers and the Headquarters for action based on the decisions taken. The Headquarters ensured that these were implemented by the Ministries in timely fashion. Each year, the Headquarters evaluated progress then updated and expanded the IP Strategic Program for the following year. So far, the Diet has passed more than 40 laws following the adoption of the Basic Law on Intellectual Property



A series of policy initiatives are helping to drive Japan's progress up the IP expressway.

“Japan already possesses some of the best patents and other IP in the world. I will set as one of our national goals that the results of research activities and creative endeavors are translated into IP rights that are strategically protected and utilized so that we can enhance the international competitiveness of Japanese industries.”

Former Prime Minister Koizumi

The ruling Liberal Democratic Party has also established a committee on IP strategy, to contribute both to discussions at the IP Strategy Headquarters and to the implementation of the IP Strategic Program. The largest industry association in Japan, Keidanren, also set up an IP committee with strong support from President Mitarai, the CEO of Canon and a member of the IP Strategy Headquarters. All these initiatives have contributed to creating a strong mechanism driving Japan towards its goal of becoming a top IP-based nation.

Courtesy of the IP Strategy HQ



Former Prime Minister Koizumi chairs a meeting of the IP Strategy Headquarters in 2003.

For the future

At the outset, I gave three instructions to my team of 30 staff at the IP Strategy Headquarters, a unique group drawn from various ministries, academia and industry. First, we should be clear about our mission, i.e. that Japan should become a leading IP-based nation. Second, we should forget the interests of the organizations from which we came, and concentrate on pursuing the best interests of our country. Third, we should keep the spirit of entrepreneurship. The IP Strategy Headquarters was ambitious and wide-ranging enough to reform Japan's IP infrastructure. By encompassing the viewpoint of the whole government, it was in a prime position to prepare an overall design for the national IP Strategic Program, and to ensure its implementation. The team worked day and night to overcome initial strong opposition in some areas.

The period from 2003 to 2006 established a solid basis for the implementation of the Strategic Program. We expect to start reaping the rewards of this effort. A lengthy action plan is under preparation for the 2007 Program; including, for example, promoting innovation; strengthening university Technology Licensing Offices; encouraging collaboration between universities and SMEs; enhancing the national response to the need for high global

competitiveness; providing more effective services in patent examination; increasing measures for combating counterfeiting and piracy; promoting the creation of new contents for the creative industries; and enhancing IP education, in order to develop human resource capabilities.

I would like to see the advent of a society where creators and innovators are truly respected, through acknowledgement that their creative works and inventions belong to them, and that reasonable remuneration should be paid to them in appreciation and as an incentive. Mechanisms to protect IP rights continue to evolve but, at the same time, must retain the delicate balance between the interests of rights-holders and those of society at large. Striking such a balance requires sensitivity and flexibility in sculpting and applying government IP policies. I hope that Japan will continue to develop as a good model of a harmonious and balanced innovative society, anchored by a supple, forward-looking and strategically-based IP system.

For more information on the Strategic Council for Intellectual Property:

www.kantei.go.jp/foreign/policy/titeki/index_e.html

INDUSTRIAL DESIGN SYMPOSIUM IN ARGENTINA

Why do businesses invest in design, and how can they protect their investment? Why register industrial designs? How can design protection best be obtained in different countries? These questions and many more were addressed at an international symposium in Buenos Aires on March 20 to 21, jointly organized by WIPO and the National Institute for Industrial Property (INPI), Argentina.

Buenos Aires, the first city ever to be designated a UNESCO City of Design in recognition of its vibrant design industry, was an ideal choice for this international symposium. Attended by designers, lawyers and officials from IP offices from five continents, the Symposium examined current issues and future trends for the protection of industrial designs. It also featured the work of leading Argentinean design businesses, represented by three very different companies, *Ferrum*, *Ruptura* and *Estudio Cabeza* (below).

Industrial design, which brings together the functional and aesthetic features of an object, spans a range of disciplines. The International Council of Societies of Industrial Designs stresses the centrality of design from both an industrial and cultural-sociological point of view, describing it as “a creative activity whose aim is to establish the multi-faceted qualities of objects, processes, services and their systems in whole life cycles.” Design, the Council concludes, is “the central factor of innovative humanization of technologies, and the crucial factor of cultural and economic exchange.”

WIPO's work on industrial design, from an intellectual property (IP) angle, focuses on creating and maintaining an international legal framework conducive to protecting the rights of designers and rights-holders. This is a complex area, with different options and schemes for protecting designs ranging from *sui generis* design laws, unregistered designs, and design patents, through to copyright and trademarks.

Industrial design or applied art?

Indeed, hardly any other subject matter within the realm of IP is as difficult to categorize as industrial design. And this has significant implications for the means and terms of its protection. If the design of a given object can be categorized as a work of applied art, for example, then it may be eligible for protection under copyright law, with the term of protection going much beyond the standard 10 or 15 years under registered design law.



FERRUM

Founded 95 years ago, Ferrum designs and produces elegant bathroom and sanitary ware. The company's marketing strategy stresses cutting edge designs combined with the reputation for quality of its long established name. In its industrial design team, skilled designers work together with specialists in engineering, marketing and computer modeling. ■

RUPTURA

Ruptura aims to generate new business opportunities by questioning the *status quo*, and developing new and better ways of doing things. The company name, explains director Washington Perez, derives from the “rupture” with existing assumptions, “such as occurred when someone first asked if a candle was the only way to make light, or a sail the only way to cross the sea.” Ruptura's toddler shoes break with convention by creating colorful images on the under-soles. These reflect the perspective of small children, who spend more time on the floor with the bottoms of their shoes displayed than standing. ■

Photos: Ferrum



A classic illustration dates back to 1929, when the Swiss architect and designer Charles Edouard Jeanneret, better known as *Le Corbusier*, developed a series of pieces of furniture, each of which was conceived purely as the concrete expression of its own function. Designers from this school focused on the concept of “use” and the necessities inherent within it. The object itself, devoid of any ornament, derives its beauty from its essential nature.

Courtesy of Cassina



A classic. The LC4 chaise longue (Cassina I Maestri Collection) designed by Le Corbusier, Pierre Jeanneret and Charlotte Perriand. Cassina now has exclusive reproduction rights.

It was more than 30 years before these items were produced industrially, and more than 60 years before the question arose as to whether *Le Corbusier's* chairs were works of applied art. This resulted in, among others, a landmark case under German copyright law.¹ An important feature of this judgement was that the criteria which determined whether or not a given object could be considered as a work of applied art for the purposes of copyright protection should not depend on the purpose of the object.

Protecting designs

Today, design is often at the heart of successful brand identity, and provides a high degree of product recognition for consumers. The Apple i-Pod, or radiator car grilles, such as DaimlerChrysler's distinctive Jeep® grille design, are just two of many examples of businesses leveraging well-established designs on to future product generations.

Successful designs, however, are also a magnet for imitators. The moment a popular design comes on the market, it will be copied. Yet, it remains the case that many designers and companies are not well informed as to the need to seek active protection, nor of the different possibilities available. Legislators are

addressing this concern. Among the new ways of obtaining rapid and cost effective design protection that the Symposium addressed is the un-registered design protection scheme of the European Union (EU). With the first successful infringement cases now being brought under EU unregistered design law, the Symposium heard about the increasing use of this relatively new right by designers and businesses.

The need for an international design registration system in which a significant number of countries participate was apparent throughout the Symposium, and the Hague System transpired as the natural model. This international registration system, administered by WIPO, has been in existence since 1925 and currently covers 47 countries. It offers a simplified, cost-effective way to obtain industrial design registration in multiple countries through the filing of a single application.

Good product design, where technical innovation, functional superiority and esthetic appeal are mutually reinforcing, is an ever more key element for successful consumer products. The Buenos Aires Symposium left no doubt that design is one IP asset that will only get hotter.

1. Decision I ZR 15/85 of December 10, 1986, which has been published in GRUR 1987, at page 903 (Le Corbusier-Möbel).



Photos: Ruptura

ESTUDIO CABEZA

The Estudio Cabeza design studio creates contemporary urban and institutional furniture, such as the benches, ramps and bins in Buenos Aires's Puerto Madero district and other public spaces. Wood, steel and concrete are given ergonomic forms and clean lines, resulting in hardwearing items which are in harmony with their surroundings. The multi-award-winning studio, which publicizes its use of design protection, also licenses its work to European and Latin-American firms. ■



Photos: Estudio Cabeza

AMERICA'S CUP

WIPO Provides Online Dispute Resolution Facility

The "Holy Grail" of the yachting world culminates with the final regattas in Valencia, Spain, from April 16 to July 7. It is the 32nd America's Cup (www.americascup.com), the renowned international sailing competition, which originated in 1851 and is considered to be the oldest active trophy in interna-

Adapting the ECAF model

The regular WIPO ECAF is available for cases arising under the WIPO Mediation, Arbitration, Expedited Arbitration and Expert Determination Rules. With the WIPO ECAF, parties, neutrals, and the Center may securely file, store, search and retrieve case-related submissions in an electronic docket from anywhere in the world and at any time. When a submission is made, all parties receive an e-mail alert and may view the docket. The WIPO ECAF also aids case management by providing – in addition to the online docket – case overview, time tracking and finance information.

Similarly, ECAF's customized ACJ interface allows an at-a-glance overview of all cases filed, and for each case, a comprehensive listing of all submissions by parties, as well as Jury notices and decisions. When a submission is made through the ACJ ECAF, all participants receive an e-mail notification. Information stored on the ACJ ECAF may be accessed by all approved participants, namely members of the Jury and parties over whom the Jury has jurisdiction under the Protocol governing the 32nd America's Cup (Protocol), including the competitors, the Race Committee, the Measurement Committee, America's Cup Management, the Challenger Commission, and all officials. A message board function on the ACJ ECAF is an additional tool that enables informal communication among participants outside the case record.

The ACJ ECAF contributes to the efficient resolution of ACJ disputes where Jury members, parties and legal representatives are based in different locations, where submissions in every case must be accessed by a number of participants, and where time is of the essence. Since its launch in March 2006, over 20 disputes have been initiated through the submission of an application on the ACJ ECAF, nearly all of which have been resolved.

The ACJ ECAF uses a secure platform and all information stored is firewall-protected and encrypted using Secure Socket Layer technology. This enhances the confidentiality of the procedure. However, Jury decisions are publicly available at jury.americascup.com, unless the Jury decides otherwise.



The web-based facility enables jury members, parties and legal representatives to access case-related submissions from anywhere in the world and at any time.

tional sport, predating the Modern Olympics by 45 years. The 32nd America's Cup began in 2004 when the *Société Nautique de Genève* – the yacht club that won the 31st America's Cup and therefore currently holds the trophy – accepted the challenge to a new competition. Twelve boats from ten countries, incorporating the latest designs and technology, are competing in the 32nd America's Cup.

So what does this have to do with WIPO? Under the America's Cup Jury (ACJ) Rules of Procedure, the ACJ is responsible for resolving disputes that may develop involving competitors and provides guidance in rule interpretation. The ACJ is comprised of five members from five countries and assisted by a Jury Secretary. Following a request from the America's Cup Management, WIPO created in-house a customized web-based facility for use in the 32nd America's Cup to facilitate efficient dispute resolution under the ACJ Rules of Procedure. This application is modeled on the WIPO Electronic Case Facility (ECAF), a user-friendly and practical web-based tool that the WIPO Arbitration and Mediation Center makes available to parties at their request.

Diverse cases

The Jury has been called upon to resolve issues as diverse as the place of yacht construction for purposes of hull inspection by competitors, and the interpretation of various racing rules.

One dispute dealt with through the ACJ ECAF involved photographs that were taken of a competitor's yacht while the team was testing new equipment outside the race area, and which were subsequently viewed by a rival team. Immediately after the application was filed, the Jury issued an interim order prohibiting publication or distribution of the photographs while proceedings were under way. The Jury accepted submissions, with one team stating that it had come into possession and viewed the photographs but had then destroyed them, and that no competitive advantage had been gained as a result of the viewing. The team requesting relief claimed that the photographs contained design information that would be beneficial to any competitor. The Jury ruled that the team which had viewed the photographs had violated certain articles of the Protocol. By way of sanction, the viewing team would have the number of sails it could use during the Challenger Selection Series reduced from 45 to 43 sails. The team was also required to pay the costs of the proceeding.

In another case, more directly related to intellectual property, the Jury was called on to determine whether a team's request to display a *Red Bull* advertisement on its hull was permissible. The Protocol allows advertisements of a limited size, and color schemes of any color or combination of colors. The Jury construed the proposed advertisement as consisting of the *Red Bull* name and the depiction of a bull, and not the combination of colors outside that area. Accordingly, the Jury approved the team's application for branding pursuant to relevant articles of the Protocol.

The 18th person

More recently, the ACJ ECAF has been further adapted to assist with the so-called 18th Person Approval process. The 18th person is an individual

the team wishes to take on board with them for a day's racing, in addition to the 17-person racing crew. Such persons may be connected to the sponsoring companies or have some public status. To prevent them from taking an individual on board with skills that would give a competitive advantage



Photo: ©ACJ 2007/Jorge Andreu

The Jury was called upon to determine whether the Red Bull advertisement displayed on the hull of this team's boat was permissible according to the Protocol.

to the team, teams must apply to the Jury to take this person on their yacht. Teams now use the ACJ ECAF to make their request and upload a sailing résumé, which details any technical and tactical skills of the proposed 18th person. All 18th person requests are then automatically notified via e-mail to everyone with access to the ACJ ECAF.

The role of WIPO's Arbitration and Mediation Center has been to develop the ACJ ECAF and provide technical support, implementing updates as necessary. This experience has driven further improvements in the regular WIPO ECAF system, so helping to confirm WIPO's pre-eminent position in the area of online dispute resolution. As the exciting final days of the 32nd America's Cup approach, the Center continues to receive positive feedback from the Jury.

SCT: WORK ON NEW TYPES OF MARKS, TRADEMARK OPPOSITION PROCEDURES AND INDUSTRIAL DESIGNS

WIPO's Standing Committee on the Law of Trademarks, Industrial Designs and Geographical Indications (SCT), attended by 77 Member States, four intergovernmental organizations and 16 non-governmental organizations, met from May 7 to 11 to pursue work on the following issues.

New types of marks

The Committee examined Member States' legislation and trademark office practices in relation to the registration of three-dimensional marks, color marks and sound marks. The exchange will continue at the SCT's November session in respect of other types of marks, such as motion marks, position marks, hologram marks, slogans, smell, feel and taste marks, and is expected to result in a set of practices for Member States relating to the representation of those types of marks in trademark office procedures.

Trademark opposition

The SCT discussed at length the issue of trademark registration opposition procedures, which offer third parties the opportunity to object to a trademark either before or after it was registered with a trademark office. Delegates considered the grounds of opposition, and examined the experience of SCT members with regard to pre-registration or post-

registration opposition. Other issues addressed included third-party observations made in the course of opposition procedures, cooling off periods allowing for settlement negotiations, Member States' experiences of introducing new opposition systems, and the effect that abolishing office examination as to prior rights can have on the number of oppositions filed. A document summarizing key learning points derived from the experiences of national and regional offices regarding opposition procedures will be considered by the SCT at its next session.

Industrial designs

The SCT fine-tuned a detailed questionnaire concerning industrial design registration in member countries, and gave the go-ahead for a comprehensive survey on various industrial design registration systems. This will be conducted in two stages, the initial survey covering design registration formalities, and the second part, later this year, covering questions of substantive design law. The exercise is intended to map the industrial design protection landscape of Member States and to explore the border areas between marks, industrial designs and copyright. This initiative, launched at the previous session, will inform the SCT's future deliberations as to whether approximation of design legislation is desirable and feasible.

State emblems, and names and abbreviations of non-governmental organizations

Delegates also worked on improving certain aspects of the procedure for the protection of state emblems and of names and abbreviations of international organizations under Article 6*ter* of the Paris Convention. The WIPO secretariat demonstrated a test version of a new online searchable database containing some 2,400 records of protected state emblems and names, abbreviations and emblems of intergovernmental organizations. Such signs are generally excluded from use as trademarks. The database does not have legal effect, and inclusion of signs is of a purely informative nature, but by improving public access to this data, it enhances the protection of those signs against unauthorized registration or use as trademarks.

The next meeting of the SCT is scheduled to take place from November 12 to 16.

WIPO AWARD WINNERS

The list below includes all the winners from April to June to the extent that the names were made available to WIPO before this Magazine went to print. We congratulate the winners and wish them continued success.

WIPO Gold Medal for Inventors

CUBA

- Mr. Orestes Rolando Contreras Alarcón, for his equipment and methodology for fast microbiological diagnosis (DIRAMIC)
- Mr. Dahis Manzanares Tapia, for SURFACEN

KUWAIT

- Mr. Fawzi Kaci Bahbahani, for his cervical therapy device
- Mr. Jaafar Abdul Kader, for his starting gate and timing device
- Mr. Jassem Maal Allah Al Kanai, for his speed method and system for a motor vehicle

KYRGYZSTAN

- Mr. Mukhammadjan Mamasaidov, in recognition of his outstanding achievements in science and as an inventor

LITHUANIA

- Mr. Pranas Baltrenas, in recognition of his outstanding achievements as an inventor

MONGOLIA

- Mr. Choglon Nanjaa, for his academic and innovative work in the area of machine production, technical erosion and metal study

PANAMA

Primer Congreso Internacional sobre observancia de los derechos de IP:

- Mr. José Eduardo Ayú Prado Canals, in recognition of his outstanding achievements in IP

SLOVENIA

Slovene Inventor's Day:

- Mr. Valentin Zupan, for a new generation of accordions

SWITZERLAND

35th Salon international des inventions et des techniques et produits nouveaux:

- Mr. Tsengué Tsengué, Best invention from a developing country, for a continuous solar dryer with functions to regulate intensity
- Mrs. Marina Myagvoka, Best woman inventor, for a tool to diagnose the intake of narcotics

TAJIKISTAN

- Mr. Azimdjoi Khushmatov, for his vodka "Araki" Shomi Dushanbe
- Mr. Azam Azizov, for his technique for intra-renal resection of the in-drawn and severed ureter at infantile nephrolithiasis

UKRAINE

- Mr. Volodymyr Komarov, for his valuable contribution to the development of science and technologies

WIPO Creativity Award

KYRGYZSTAN

- Mr. Omor Sultanov, in recognition of his outstanding achievements in literature
- Mr. Sardarbek Jumaliyev, in recognition of his outstanding achievements in the musical arts
- Mr. Taalai Kurmanov, in recognition of his outstanding achievements in fine arts

LITHUANIA

- Mr. Arunas Matelis, in recognition of his outstanding achievements as an author of documentary films and as a film director
- Mrs. Violeta Urmanaviciute, in recognition of her outstanding achievements as an opera singer

MOLDOVA

- Mr. Grigore Vieru, in recognition of his outstanding achievements in literature

SUDAN

- Mr. Beshir El Bakri, in recognition of his significant contribution for the past 50 years to the field of literature, creative writing and copyright protection

WIPO Trophy (Innovative Enterprise)

CUBA

- Cubaron SA, for its active use of the IP system

LITHUANIA

- Kaunas University of Technology, for its active use of the IP system

MOLDOVA

Info-invent Exhibition:

- Institute of Chemistry of the Academy of Sciences of Moldova

RUSSIAN FEDERATION

10th International Salon of Industrial Property "Archimedes":

- All-Russian Society of Inventors and rationalizers, in recognition of its contribution to the development of innovation and technical creativity and to the promotion and protection of IP

SLOVAKIA

- Editorial Board of the Magazine "Intellectual Property", for achievements on the occasion of 10th Anniversary of the establishment of the Magazine

SLOVENIA



- Natura Planinca Farm Group, for its ecological farming techniques using its own energy system, managing secondary waste, creating new farm production methods and products
- Ekstundo, for its movable wheel hub, a revolution in the bicycle industry which increases energy efficiency 10-15 percent

More information: www.wipo.int/innovation/en/wipo_awards/

The free brochure "WIPO Awards Program" is available from Publications.Mail@wipo.int.

LETTERS AND COMMENT

Winning the trust of the 'digital natives'



The kids quoted in your article, *Talking to the Download Generation* (issue no. 1/2007), represent today's "digital natives." These are the young people who grew up with mobile phones in their pockets, who are used to getting whatever content they want, however and whenever they want it – and for free.

Edelman, a global public relations firm, recently commissioned research on 18-34 year olds in the U.K. and France, exploring attitudes and issues of trust towards the entertainment industry. Key amongst those findings: 41% of those surveyed in the U.K., and 54% in France, do *not trust* entertainment companies to provide "value for money."

When communicating messages of anti-piracy to this key demographic, companies need to address their potential top-of-mind question: "*What value will I get if I buy something that I could download for free?*"

The answer and corresponding messages of 'value for money' can be articulated in a myriad of ways – such as the quality of the entertainment experience via better picture and sound, or the peace of mind knowing that you are not exposing your computer

to viruses or your family to pornography, gateways opened through peer-to-peer file-sharing. In focus groups conducted in years past on behalf of clients, we found it was the parents' experience of having to buy a new family computer due to virus infestation that often led them to ban their children from illegal downloading.

The good news is that 69% of respondents in the U.K. and 59% in France said they trusted the entertainment industry to make content widely and legally available online. That's a significant departure from not so long ago.

So if the first phase of education is to make consumers aware of the availability of legal content, then phase two is where the industry can build trust by leading on issues that these consumers really care about: changing business models to serve new technologies, leading the distribution revolution and demonstrating that "value for money" proposition.

Eight years of studying institutional trust has taught that institutions of all kinds have to listen to and participate in the public discussion of their actions, products and reputations. The entertainment industry is no different. ■

From Gail Becker, Edelman, President, Western Region, Global Head of Digital Entertainment, Rights and Technology Practice, Los Angeles, U.S.A.

P2P and the copyright challenge

In *IP Infringements on the Internet – Some Legal Considerations* (issue no. 1/2007) you suggest some countermeasures for copyright owners when their rights are infringed on the network. But with the extensive application of peer-to-peer (P2P) technology, those recommendations are not enough to safeguard their rights.

P2P technology changes the traditional client/server information transfer mode as users download and share information with P2P software. Copyright-protected content is not stored in central servers, but in the computers of every P2P user, making thousands of users direct infringers. Deciding where to sue is also difficult. An Internet Service Provider (ISP) in China may be sued by a rights owner in the U.S. for supplying copyright-protected music on its website. But it would be unimaginable to sue numerous individual Chinese ►

Putting IP on the curriculum

As a professor at the University of Tolosa in the state of Zacatecas, Mexico, and a regular subscriber to WIPO Magazine, I would like to share a positive experience in the teaching of IP. I am from Cuba, where previously I headed a regional office. When I came to Mexico, I was struck by the fact that, although a solid IP infrastructure existed at the federal level, IP matters went largely unnoticed among business and educational sectors in many states. In Zacatecas, for example, IP did not feature in university curricula, resulting in total ignorance among graduates about IP matters, which are so transcendental in today's knowledge society.

This year, it fell to me to teach the *Legal Framework of Design* on the graphic design course. But the curriculum, as originally conceived, was inadequate, only really dealing with copyright aspects. So I took on the challenge of overhauling the program, drawing on my experience both from Cuba and from WIPO courses.

While initially apprehensive about the apparent complexity of the subject matter, the students proved highly motivated and achieved an extraordinarily high level of IP knowledge. They also went out into the streets and canvassed people's opinions, recording these on video. This way they saw for themselves the lack of understanding of IP rights in Zacatecas, and the way in which this not only undermines respect for creators' rights, but also "justifies" the thriving piracy industry. The students derived great satisfaction from having learned so much about IP, but their research left them perturbed about the future of any state which keeps its back turned to IP. ■

From Yordanka Masó Dominico, University of Tolosa, and Head of Lex Securus IP Services, Zacatecas, Mexico

"Time to do new things" in Turkey

It is now two years since the report you published on the activities of our Turkish Patent Institute (TPE) (issue no. 6/2004), and your readers may be interested to hear about our latest project.

Project *Hezarfen*, which began in early 2006, tackles innovation promotion from both inside the TPE (improving our infrastructure, services and products) and outside (helping SME's to develop an innovation-based culture through the use of industrial property). We have a pilot project underway in one of the biggest industrial zones in Turkey, OSTIM OSB, which of-

fers one-to-one SME consultancy services, advice on using IP information in each phase of innovation, and on the strategic use of IP in the innovation management process etc. Through this project, the TPE is developing its practical knowledge, enhancing communication with industry, and transforming knowledge into practice.

Our project slogan, *It's time to do new things*, paraphrases the words of the Turkish philosopher, Mevlana. The project itself is named after Hezarfen Ahmet Çelebi, one of the first aviators to fly successfully with artificial wings, who flew across

the Bosphorus in 1638. His name means "person who knows thousands of sciences" – which we interpret in our *Hezarfen* project as "SME's which know thousands of business strategies." ■



From Arife Yilmaz, Patent Examiner – Hezarfen Project Coordinator, Innovation Support Services, Turkish Patent Institute, Ankara

► students for downloading a song with P2P software, even if the ISP was willing to provide their identity. Infringers may be all over the world, and the cost for copyright owners of safeguarding their rights may far exceed their financial means.

Developments in network technology break the balance between right owners and the public established by the current copyright system. It is very difficult to solve this problem through legal means alone. Technical means, such as Digital Rights Management systems and the Creative Commons system, need also be utilized and developed to eliminate the conflict between the two sides. ■

From Cheng Zhaoqi, student, University of Science and Technology of China, Hefei, China



Courtesy of Y. Masó Dominico

The graphic design students achieved an impressive level of IP knowledge.



Courtesy of the TPE

Training the trainers for the Hezarfen project

IN THE NEWS

Counterfeit Museum of Shame



Photo: ©Tomas Rehle/antur

The Plagiarius Museum designed by Reinhard Angelis, Planung Architektur Gestaltung.

Action Plagiarius, which each year hands out its 'name and shame' award to deter counterfeiters, has now opened a museum in Solingen, Germany, exhibiting its 30-year collection of counterfeit goods.

In 1977, when Professor Rido Busse announced the first Plagiarius award to a Japanese company for shamelessly copying some scales he had designed for a German interior decoration firm, the event attracted little attention. But the following year several companies sent him counterfeit copies of their original designs and the idea took off. This year the award – a black garden gnome with a golden nose – was

handed out to 12 counterfeiting companies for products ranging from petrol pump nozzles, to shopping bags, to medical implements. The publicity resulting from the activities of Action Plagiarius helps to increase awareness among the public of the problem of counterfeiting; and among entrepreneurs and designers of the importance of protecting their IP rights. The organization says that some "prize winners" acknowledge their unethical behavior and seek agreements with the original producer (e.g. payment of a licence or compensation fee, or withdrawal of the product from the market).

Like the award, the Plagiarius Museum, which opened on April 1, focuses on goods produced by small companies and designers. These are the hardest hit by the effects of counterfeiting, often having invested all their resources, as well as their own creative efforts, in getting their product to market. They do not have the consumer brand recognition of major trademarks to protect them, nor the funds and know how to fight off counterfeiters. Action Plagiarius also offers legal advice and workshops to small companies to help them fight against counterfeiters. ■

For more information:

www.plagiarius.com/e_museum.html

EMI Makes Available High-Quality DRM-Free Downloads

EMI Music, the recorded music division of EMI Group, the world's largest independent music company, announced on April 2 that it would make its entire digital repertoire available in high quality downloads and free of digital rights management restrictions (DRM). The premium-quality downloads, launched in Apple's iTunes Stores, are slightly more expensive than the regular quality DRM-protected music which iTunes will continue to sell.

The Chief Executive Officer of the EMI Group, Eric Nicoli, said "Our goal is to give consumers the best possible digital music experience. By providing DRM-free downloads we aim to address the lack of interoperability which is frustrating for many music fans. We believe that offering consumers the opportunity to buy higher quality tracks and listen to them on the device of their choice will boost sales of digital music."

When it comes to the Internet, EMI has had the lead in the music industry since it released David Bowie's "Hours" as a digital download in 1999. ■

Electronic Patent Filing in China

Companies and inventors in China can now file international patent applications under the Patent Cooperation Treaty (PCT) electronically with the State Intellectual Property Office of China (SIPO). The integration of PCT-SAFE (Secure Applications Filed Electronically) software into the operations of SIPO on May 1 will generate operational efficiencies by reducing the need to han-

dle paper and by eliminating the use of traditional mail for filing.

Applicants will also enjoy significant benefits, including certain fee reductions, reduced printing, copying and mailing costs, almost immediate notification that their application has been received and is being processed and secure transmission of international applications.

PCT filings originating from China grew by 56.8 percent from 2005 to 2006, making China the 8th largest country of origin for PCT filings. China is the 4th largest patent office in the world in terms of the number of applications filed – patent filings by Chinese residents grew more than five-fold between 1995 and 2004 to reach 65,786. ■

Malaysia – RM5 Billion Fund for IP

On World Intellectual Property Day the Malaysian Prime Minister Datuk Seri Abdullah Ahmad Badawi announced the creation of a RM5 billion (US\$1.47 billion) fund to develop the country's intellectual property (IP) system. The money will go toward improving and accelerating the processing of IP titles, assisting local inventors to conduct research and register their IP, creating an IP Court – to open in June – and IP awareness raising activities.

Malaysian statistics show that only 7 percent of the 87,846 patent applications filed in the country since 1986 came from nationals and that it took on average five years – and sometimes up to seven years – to approve the registration of an IP title. The government's National Intellectual Property Policy is aimed at bringing down the registration time for patents to 3.5 years and for trademark, already reduced to 3 years, to 12 months. ■

Design for the Other 90%



Woman in the Jukwa market in Ghana making high-density briquettes using a press designed and manufactured by MIT D-Lab.



The Bamboo treadle pump designed by Gunnar Barnes and International Development Enterprises Nepal is manufactured in numerous small and medium-sized local workshops in Nepal and Bangladesh.

On May 5, the Cooper-Hewitt National Design Foundation in New York opened an exhibition entitled "Design for the Other 90%," which focuses on humanitarian designers. The exhibition brings 30 humanitarian design projects to the fore, highlighting the growing trend among designers to create socially responsible and affordable objects for the world's poorest, who have limited access to food and water, shelter and health-care, education, energy and transport.

Many of the objects in the exhibition have been co-created by the designers working directly with the end users in the field. They show the human potential to transform and improve his environment. The exhibition will run until September 23. ■

For more information visit www.cooperhewitt.org/EXHIBITIONS/other/

Calendar of Meetings

JUNE 6 TO 8 ■ GENEVA

■ *Interregional Intermediate Seminar on Industrial Property*

The WIPO Worldwide Academy will organize this annual seminar directed to officials from industrial property offices or relevant Ministries from developing countries, and countries in transition to a market economy. The seminar will be followed by practical training courses of two weeks at the national or regional industrial property offices.

Invitations: As participants, the States members of WIPO, developing countries and countries in transition to a market economy.

JUNE 11 AND 12 ■ GENEVA

■ *WIPO Workshops for Mediators in Intellectual Property Disputes*

An annual event for all parties interested in WIPO mediation procedures.

Invitations: Open to interested parties, against payment of a fee.

JUNE 11 TO 15 ■ GENEVA

■ *Provisional Committee on Proposals Related to a WIPO Development Agenda (PCDA) (Fourth session)*

This session is to further consider the proposals submitted by Member States.

Invitations: As members, the States members of WIPO; as observers, other States and certain organizations.

JUNE 14 AND 15 ■ GENEVA

■ *WIPO Advanced Workshop for Mediators in Intellectual Property Disputes*

An annual event for all parties who wish to further develop their mediation skills taught by the instructors of the annual WIPO Workshop for Mediators in Intellectual Property Disputes.

Invitations: Open to interested parties, against payment of a fee.

JUNE 18 (P.M.) ■ GENEVA

■ *Patent Colloquium: National Strategies for Innovation*

WIPO is holding a number of colloquia on selected patent issues throughout the year. The colloquia are intended to provide information on different patent-related topics and to provide a forum for an exchange of information among participants on these topics. Each colloquium will include two presentations by invited speakers, followed by a discussion.

Invitations: The colloquia are open to the public and free of charge.

JUNE 18 TO 22 ■ GENEVA

■ *Standing Committee on Copyright and Related Rights (2nd Special session)*

The Committee will continue its ongoing work on the preparation of a diplomatic conference for a treaty on the protection of broadcasting organizations.

Invitations: As members, the States members of WIPO and/or the Berne Union, and the European Community; as observers, certain organizations.

JULY 2 TO 10 ■ GENEVA

■ *Intergovernmental Committee on Intellectual Property and Genetic Resources, Traditional Knowledge and Folklore (Eleventh session)*

In continuing its work based on the renewed mandate established by the General Assembly, the Committee will consider agreed sets of issues regarding the protection of traditional knowledge and traditional cultural expressions/folklore, continue consideration of draft texts of policy objectives and principles for protection, consider issues relating to genetic resources, and address other ongoing work.

Invitations: As members, the States members of WIPO and/or the Paris Union, and the European Community; as observers, certain organizations.

NEW PRODUCTS



Singapore Treaty on the Law of Trademarks, Regulations Under the Singapore Treaty on the Law of Trademarks, and Resolution by the Diplomatic Conference Supplementary to the Singapore Treaty on the Law of Trademarks and the Regulations Thereunder, done at Singapore on March, 2006
English no. 259E, French no. 259F, Spanish no. 259S
20 Swiss francs (plus shipping and handling)



Guide to the International Registration of Marks under the Madrid Agreement and the Madrid Protocol (updated April 2007)
English no. 455E
60 Swiss francs (plus shipping and handling)

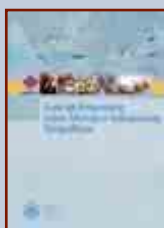

Guía des Empresario sobre Marcas e Indicaciones Geográficas
Spanish no. 859S
25 Swiss francs (plus shipping and handling)



Clasificación Internacional de Patentes (CIP) - Información General,
Octava edición
Spanish no. 409S/8
Free of charge



Comprendre la propriété industrielle
French no. 895F, Spanish no. 895S
Free of charge



Comprendre le droit d'auteur et les droits connexes
French no. 909F, Spanish no. 909S
Free of charge

Purchase publications online: www.wipo.int/ebookshop

Download free information products: www.wipo.int/publications/

The above publications may also be obtained from WIPO's Design, Marketing, and Distribution Section:
34, chemin des Colombettes, P.O. Box 18, CH-1211 Geneva 20, Switzerland. Fax: +41 22 740 18 12
e-mail: publications.mail@wipo.int

Orders should indicate:

- (a) the number or letter code of the publication desired, the language, the number of copies
- (b) the full address for mailing
- (c) the mail mode (surface or air).

For more information contact
WIPO at:

Address:

34, chemin des Colombettes
P.O. Box 18
CH-1211 Geneva 20
Switzerland

Telephone:

+41 22 338 91 11

Fax:

+41 22 733 54 28

e-mail:

wipo.mail@wipo.int

or its New York Coordination
Office at:

Address:

2, United Nations Plaza
Suite 2525
New York, N.Y. 10017
United States of America

Telephone:

+1 212 963 6813

Fax:

+1 212 963 4801

e-mail:

wipo@un.org

Visit the WIPO website at:

www.wipo.int

**and order from the WIPO Electronic
Bookshop at**

www.wipo.int/ebookshop

The WIPO Magazine is published bimonthly by the World Intellectual Property Organization (WIPO), Geneva, Switzerland. It is intended to help broaden public understanding of intellectual property and of WIPO's work, and is not an official document of WIPO. Views expressed in articles and letters by external contributors do not necessarily reflect those of WIPO.

The WIPO Magazine is distributed free of charge.

If you are interested in receiving copies, contact:

Design, Marketing, and Distribution Section
WIPO

34, chemin des Colombettes
P.O. Box 18
CH-1211 Geneva 20
Switzerland

Fax: +41 22 740 18 12

e-mail: publications.mail@wipo.int

For comments or questions, contact:

The Editor, WIPO Magazine

WipoMagazine@wipo.int

Copyright ©2007 World Intellectual Property Organization

All rights reserved. Articles contained herein may be reproduced for educational purposes. No part may, however, be reproduced for commercial purposes without the express written consent of the Communications and Public Outreach Division, World Intellectual Property Organization, P.O. Box 18, CH-1211 Geneva 20, Switzerland.