

WIPO TRAINING OF TRAINERS PROGRAM ON INTELLECTUAL PROPERTY RIGHTS

Hyderabad
August 13 – 17th 2007

Prof. (Dr.) Siddharth Jabade

Coordinator IPR Facilitation Centre

Vishwakarma Institute of Technology

666, Upper Indiranagar, Bibwewadi, Pune 4110

skjabade@yahoo.com

[Cell: 988 1408392](tel:9881408392)

*"...Because its purpose is to create a customer, business has two—and only two functions: **Marketing and innovation**. Marketing and innovation produce results, all the rest are costs." **Peter Drucker***

Patents are Granted for

INVENTIONS

to

aid

Commercial Exploitation

*Patent protection
relevant to large hi-tech
products*

How do I invent?

*Investment of large
sums*

*Patents not relevant to
the line of business*

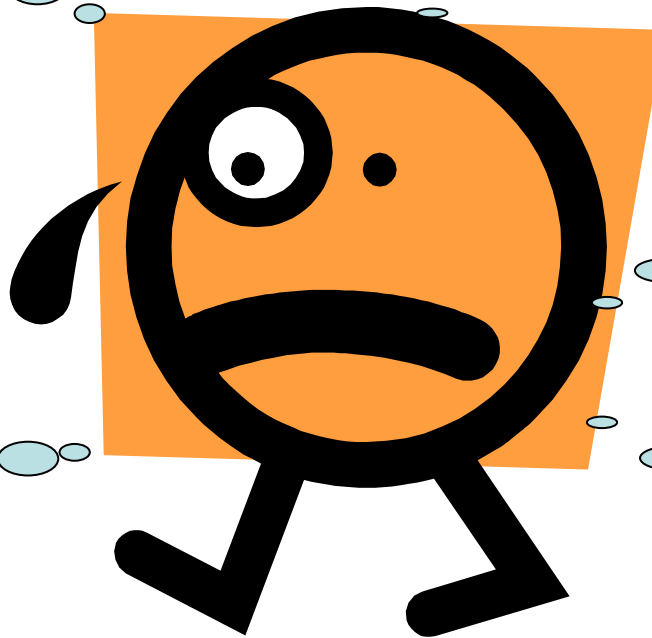

*Patent system too
complex*

Yes: "U"clip is Patented !

No. 742,892.

PATENTED NOV. 3, 1903.

G. W. MCGILL.
SPRING CLIP.

APPLICATION FILED JUNE 1, 1903.

NO MODEL.

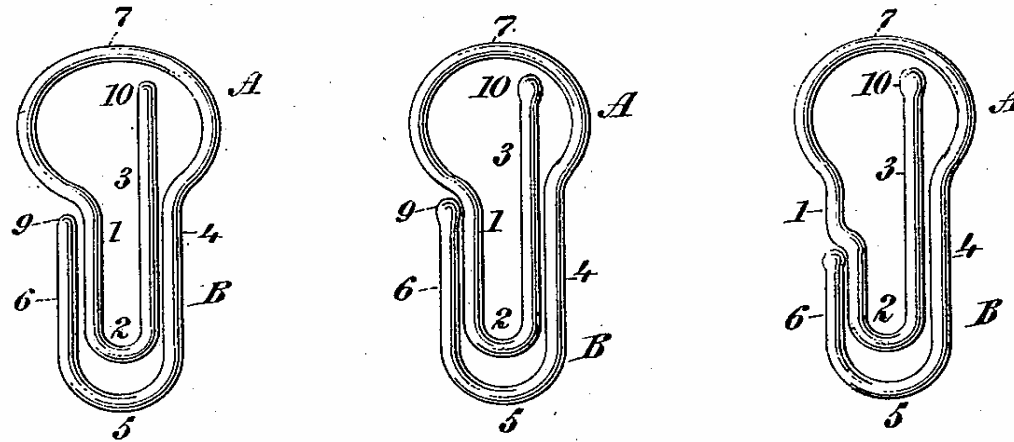

This Clip is **ALSO** Patented

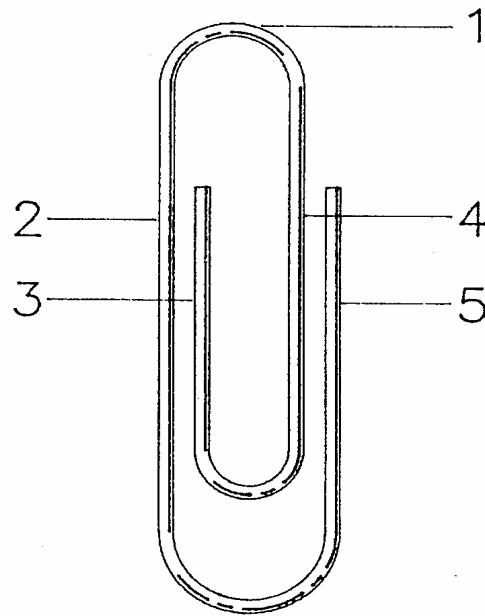
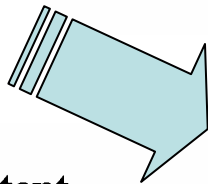

FIG. 1



U.S. Patent

Jul. 16, 1996

Sheet 1 of 2

5,535,486

Patent is a Property

Right to **exclude** others from illegitimate use

of Patented **INVENTION**

within **territory** of grant

For a

Limited period of time In consideration of the

Appropriate **DISCLOSURE** in a specified

format

Patentable Invention

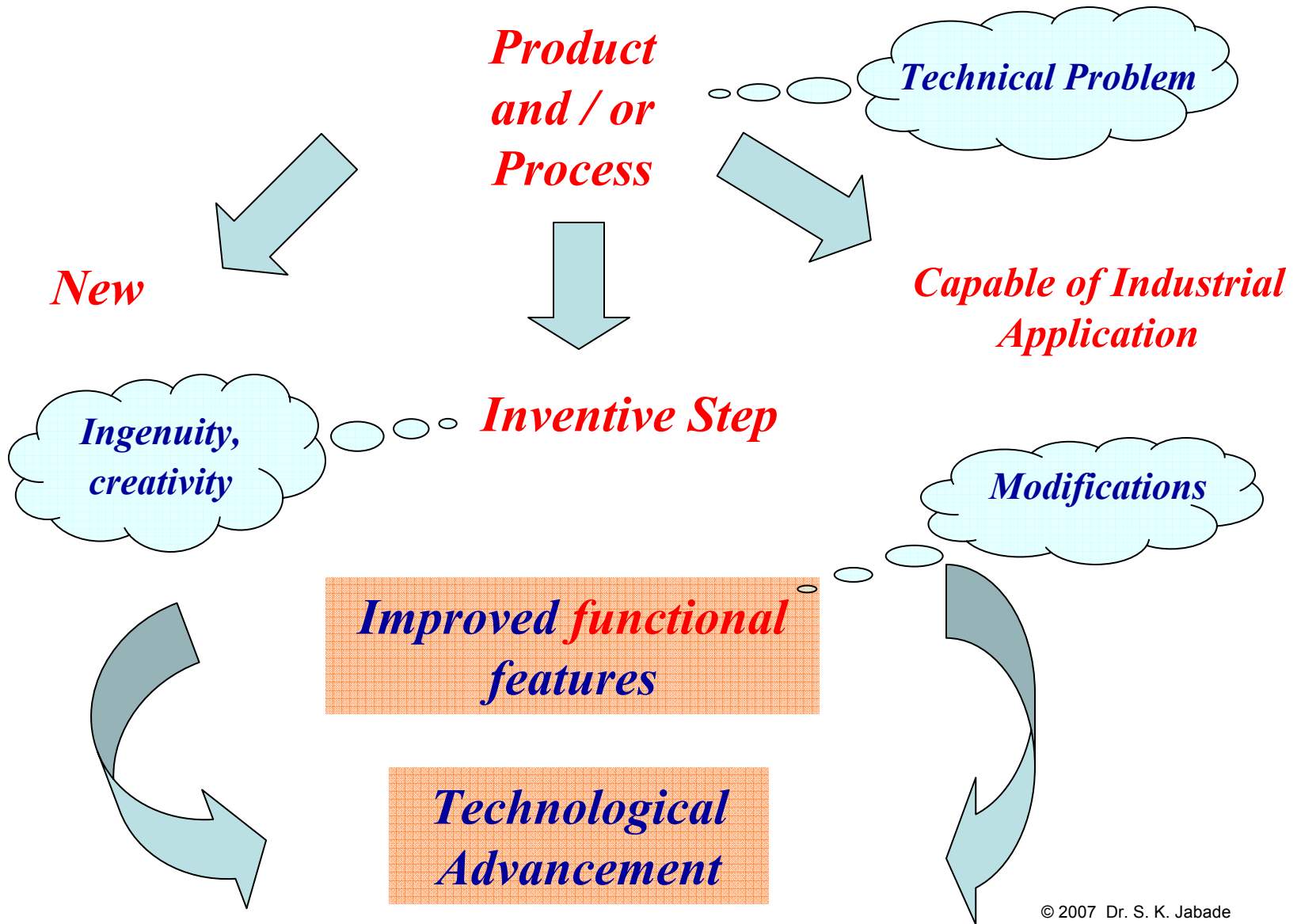

What is New ?

Invention does not form part of existing

relevant



Knowledge



Available to Public

Anywhere in the

World

Prior to First Filing of Patent Application

What is Inventive ?

Not obvious to person skilled in art

Existing Knowledge

Economic Significance

Technical advance

Common Notions

**Patent is merely
a LEGAL
document**

**Patent is not
relevant to
company**

**Acquiring
information is
COSTLY process**

**Sufficient
literature is
available in
TRADE literature**

**All information is
available in technical
journals, books etc.**

**The Reality is
something else**

**Patent Search to
be carried out
ONLY at the time
of PATENTING
INVENTIONS**

Innovation Process and Patenting

Identify Technical Problem

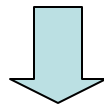

**Search and Analyse approaches
towards solving the problem from the prior art**

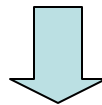

**Based on the Prior Art Analysis
Tailor the New and Inventive Technical Solution**

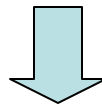

Establish and Demonstrate the concept

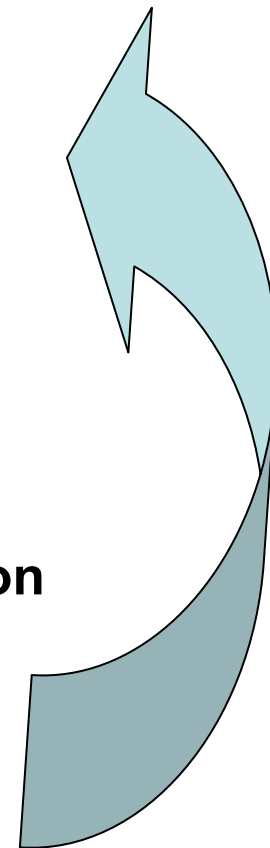
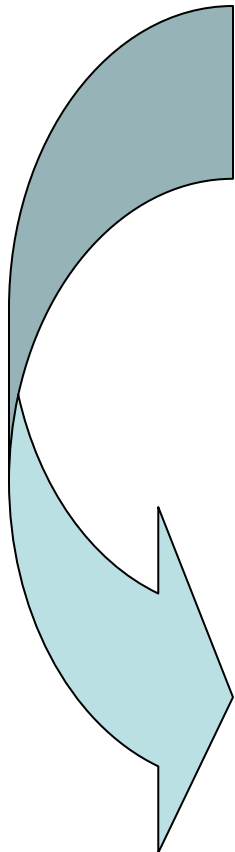

Invention Process

- Problem: To be “Mobile”
- What is the Solution?
- What is Inventive?
- Wheel 1 rotates in tandem with wheel 2 by virtue of the member
- What is Functionality?

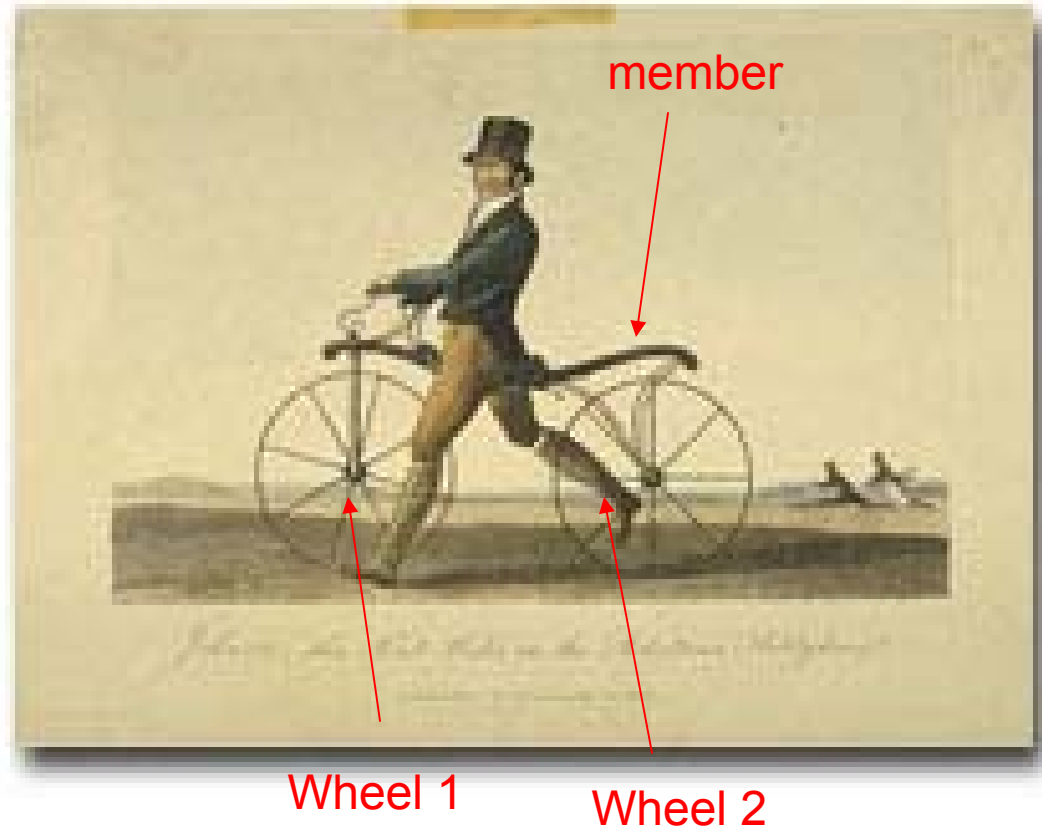

Patentable Modification

member

- Problem: push with feet
- What is the Solution?
- What is Inventive?
- Wheel 1 rotates in tandem with wheel 2 by virtue of the member
- What is Functionality?

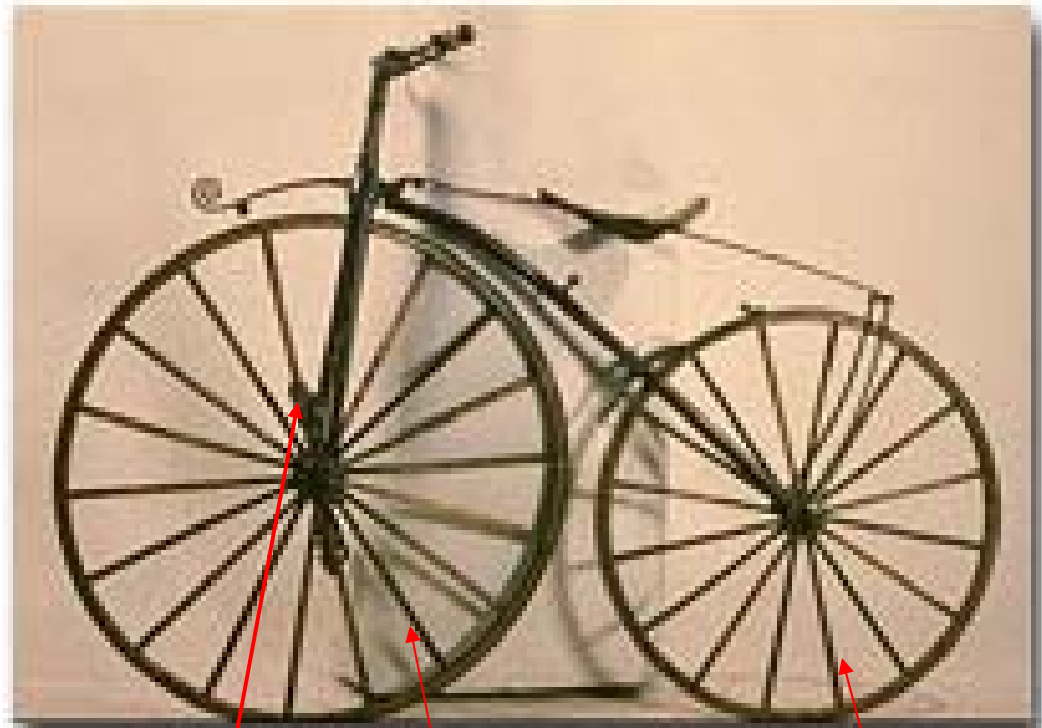

Paddle

Wheel 1

Wheel 2

© 2007 Dr. S. K. Jadhav

Further modification

- **Problem: Difficulty in pedaling**
- **What is the Solution?**
- **What is Inventive?**
- **Wheel 1 rotates in tandem with wheel 2 by virtue of the member**
- **What is Functionality?**



Chain

Patent Information: An Effective Tool for Business Strategy

Competitive Edge

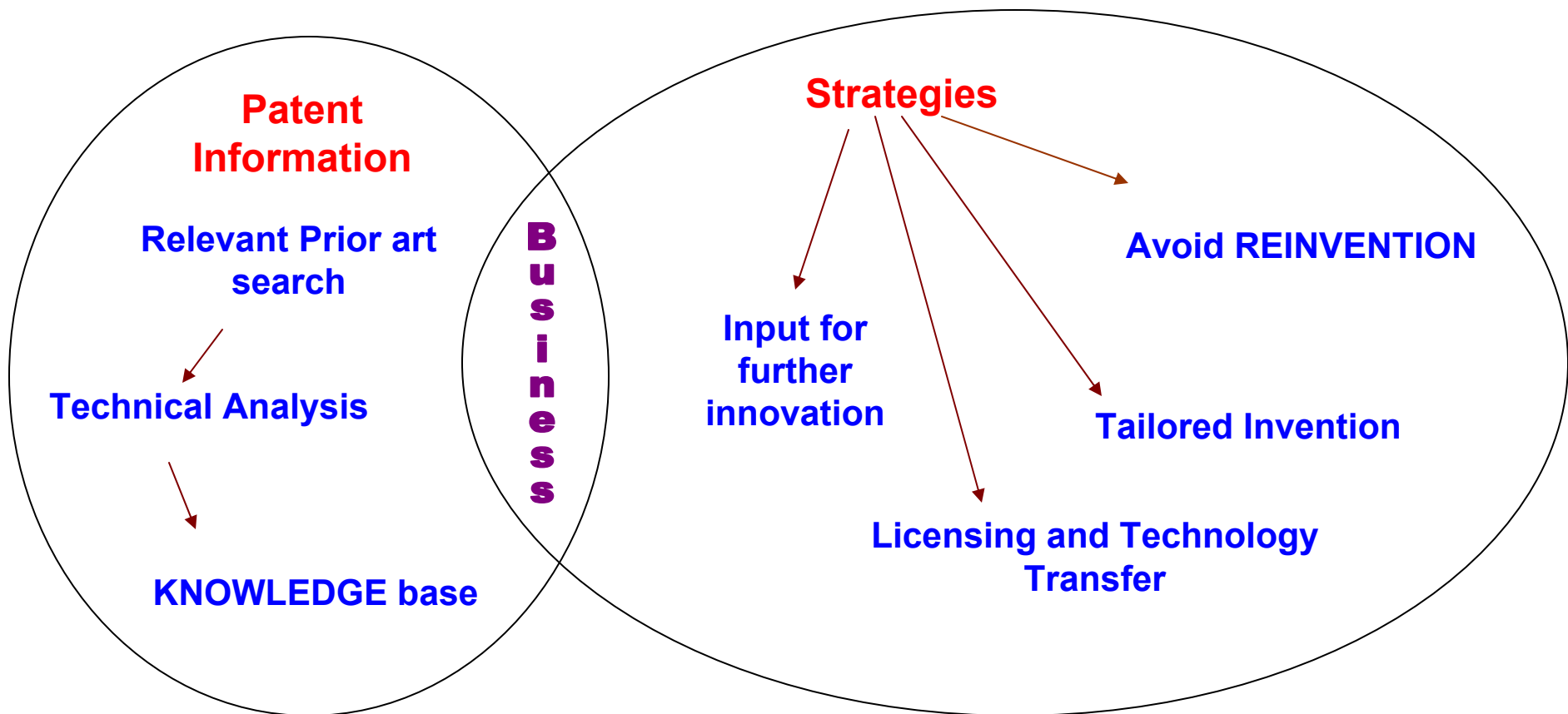

Thank You