



REPUBLIC OF SOUTH AFRICA



Regional Seminar for Certain African Countries on the Implementation and Use of Several Patent-Related Flexibilities

***Topic 2: The Multilateral Legal Framework of Patents and the
International Agenda***

**Durban, South Africa
January 29 to 31, 2013**



Topic 2: The Multilateral Legal Framework of Patents and the International Agenda

Regional Seminar for Certain African Countries on Patent-Related Flexibilities

**Durban
January 29 to 31, 2013**

Philippe Baechtold
Director, Patent Law Division, WIPO

Outline

- The international patent system today and some of the challenges it faces
- What the patent system is meant to achieve and its changing role
- WIPO (and other) efforts to get there
 - Legal
 - Practical
- Some trends

The international legal framework today

WIPO (choice à la carte)

Paris Convention, 174 MS (few substantive obligations);
specialized agreements (Art. 19 Paris):

- PCT (1970, 146 CS); IPC (1971, 62 CS); Budapest Treaty (1977, 78 CS); PLT (2000, 32 CP)

WTO (one single menu), 157 Members

TRIPS Agreement

- Comprehensive agreement
- Minimum standards; enforcement of IPRs; WTO dispute settlement procedures

Regional agreements (e.g. EPO, EAPO, ARIPO, OAPI, GCC)

Bilateral agreements (trade agreements and others)

Some views on the patent system

- **A country without a patent office and good patent laws is just a crab and can't travel any way but sideways and backwards.**

Mark Twain, A Connecticut Yankee in King Arthur's Court (1889)

- ***The Patent Office is the mother-in-law of invention.***

Anonymous

- ***The good patent gives the world something it did not truly have before, whereas the bad patent has the effect of trying to take away from the world something which it effectively already had.***

Giles Sutherland Rich (US judge)

- **Patents and innovation are a critical component of IBM's high-value business strategy.**

Samsung and IBM announcing a cross-licensing agreement

- **In the electronics industry, patents are of no value whatsoever in spurring research and development.**

Vice-president of Intel Corporation, Business Week, 11 May 1981.

The international patent system today

- Present situation:
 - claims for more innovation and dissemination of technologies (for development and wealth), but also criticism (as to increasing number of “monopoly” rights; doubtful patents)
 - multilateral approach in difficulty (e.g. harmonization)
 - constant search for balance
- To simplify, challenges today are twofold:
 - intrinsic to the patent system and
 - external to, but related to, the patent system

Challenges internal to the patent system

- Economic challenge: success and expansion of demand, in particular, in knowledge creation (need for protection); workload issues, backlogs
- Geographical challenge:
 - Important increase from several countries in Asia (China, Japan, Republic of Korea); 29% of PCT applications
 - internationalization of technology production: e.g. international co-authorship of scientific articles increased 3 times compared to 1985
This has impact on prior art, access to documents and the multiplicity of languages
- Legal aspects:
 - inadequate protection (too weak or too strong protection); adequacy of patent system for all areas?
 - enhance validity and quality

The international patent system today

Patent Applications Worldwide

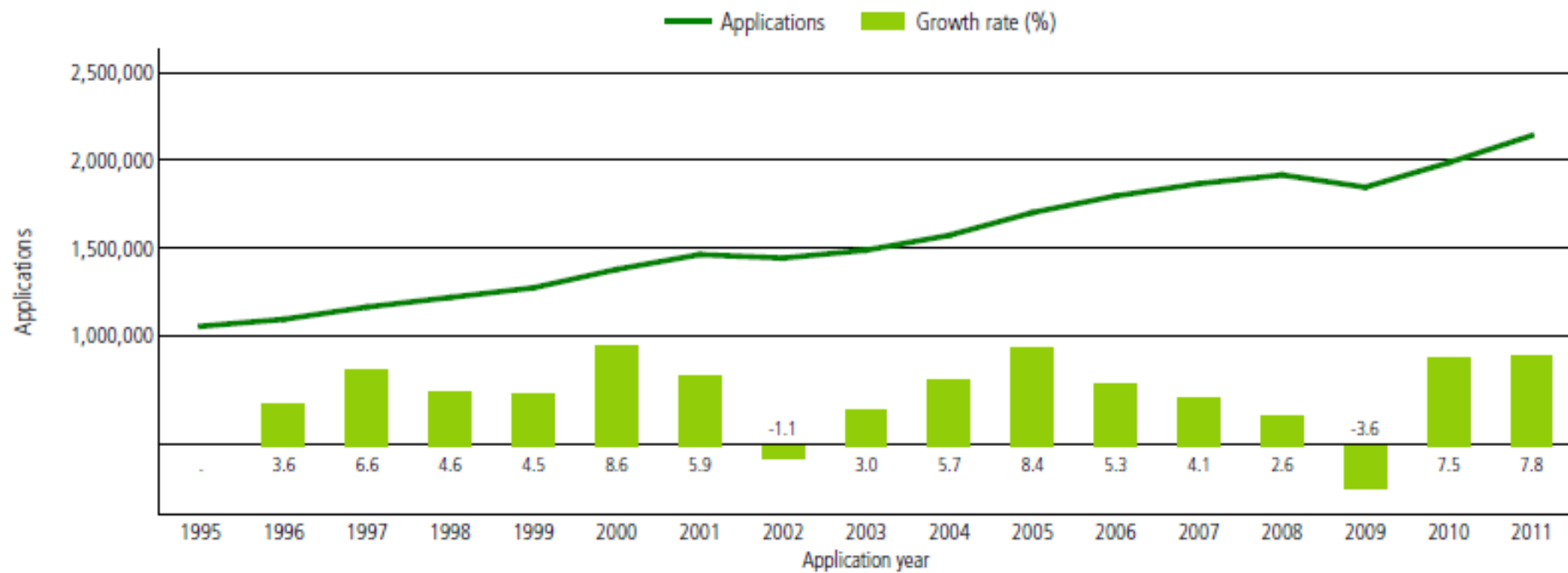

Source: WIPO Statistics Database, June 2010

Patent Applications Worldwide: residents v non-residents

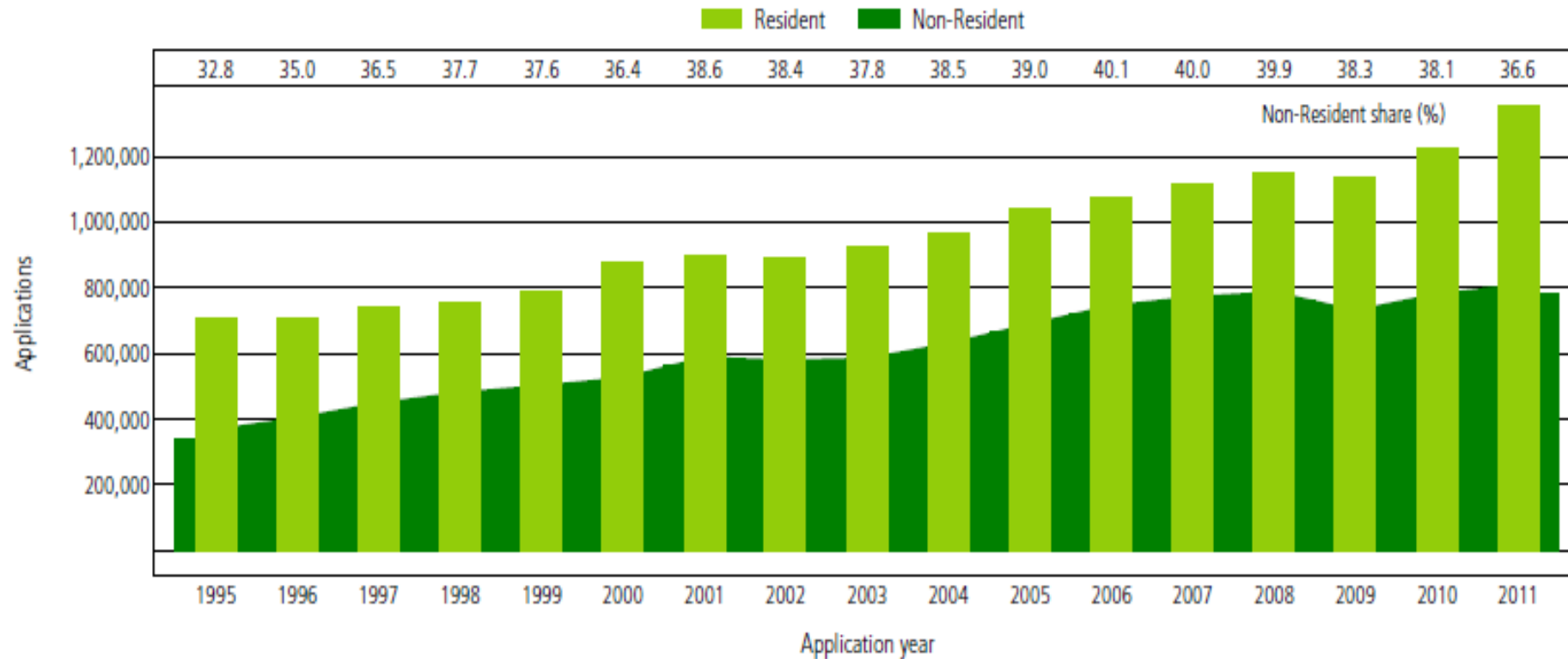

Note: See note for Figure A.1.1.1.

Source: WIPO Statistics Database, October 2012

Trends in PCT Applications: 1995 - 2011

In 2011, 182,354 PCT applications were filed, representing a 11% increase compared to 2010.

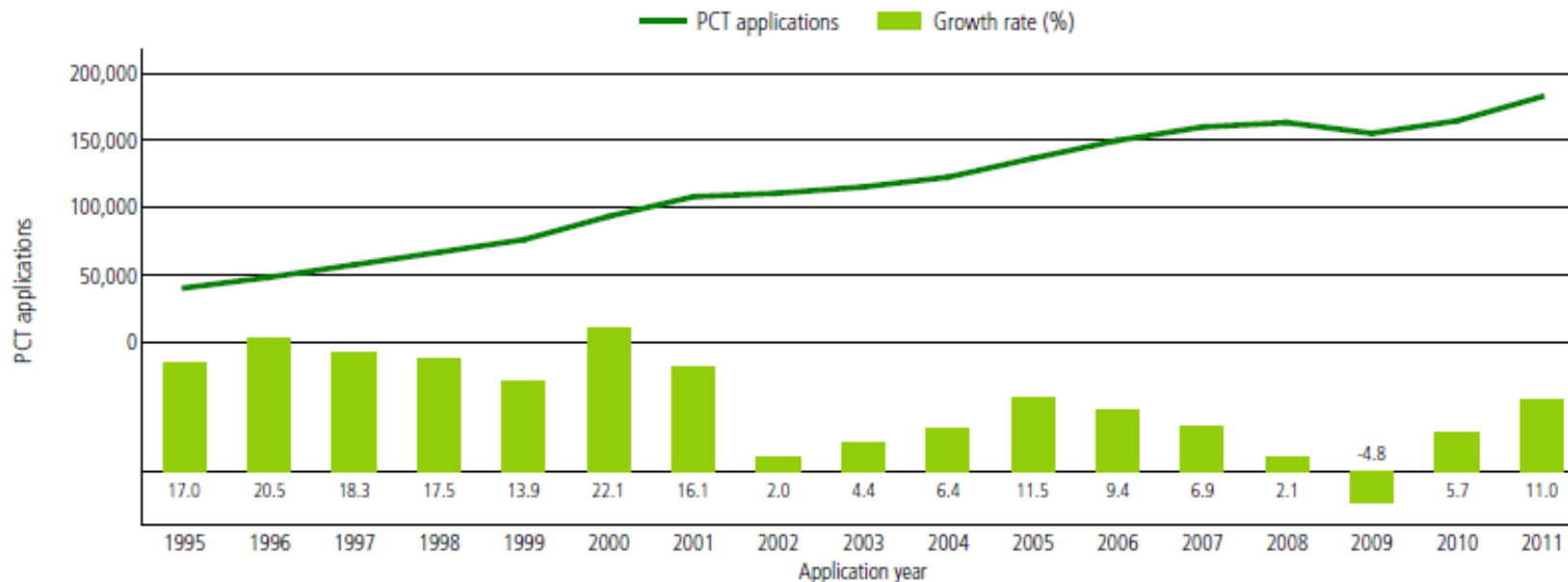

ote: Data refer to the international phase of the PCT system. Counts are based on the international application date.

ource: WIPO Statistics Database, October 2012

Potentially pending applications

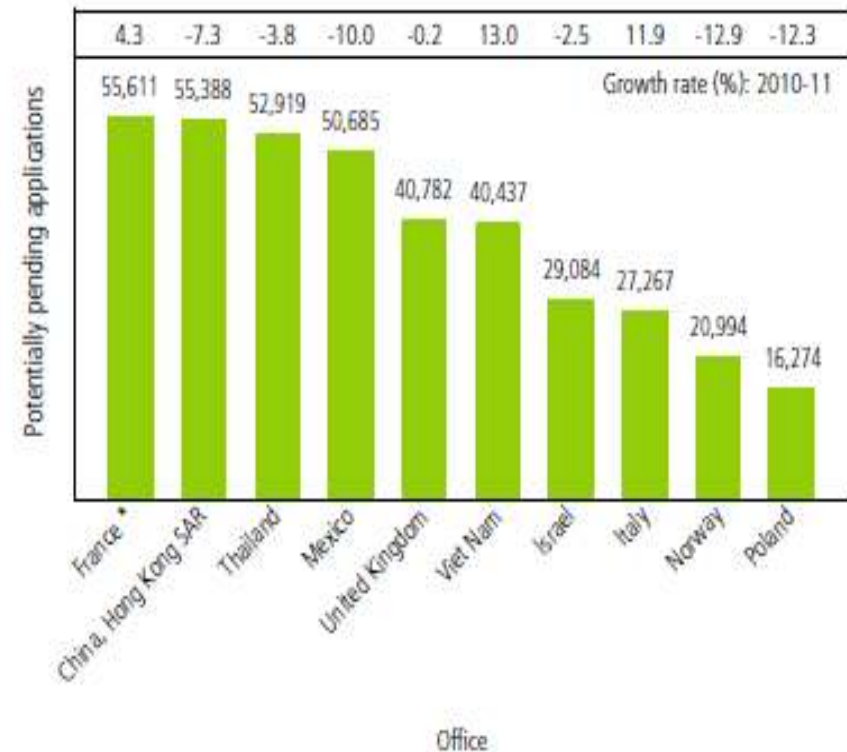
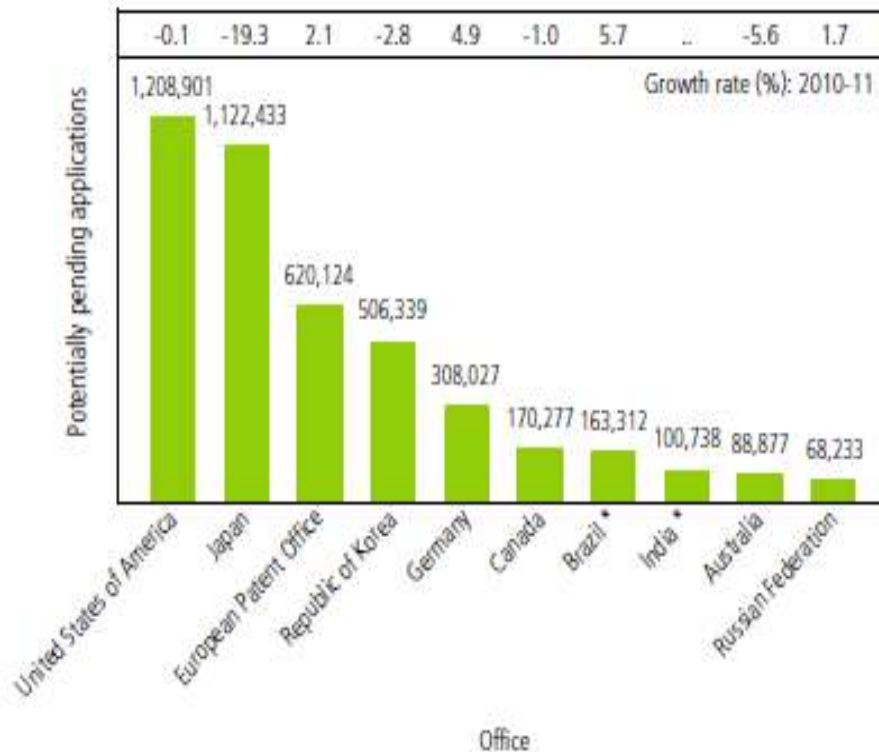

Note: *2010 data; '..' not available; Growth rate refers to 2009-2010. Potentially pending applications include all patent applications, at any stage in the process, that await a final decision by the patent office, including those applications for which applicants have not filed a request for examination (where applicable).

Source: WIPO Statistics Database, October 2012

Source: WIPO Statistics Database

External challenges: the broader policy arena

- Political: patent policy recognized as integral part of national trade, development, public health, science and research policies:
 - global challenges and questions about the social and economic impact of patents (particularly in the area of public health, climate change, biotechnology, food security); different levels of development
 - increasing number of international fora; increased participation of civil society
 - pace of multilateralism
- New technologies and new economic reality: Internet and biotechnology; software; nanotechnology. Transition to knowledge-based economy. Prior art
- Interface with other issues, e.g. competition, standards
- Other business-models, e.g. open innovation models

US Patent 5727565 Kissing shield

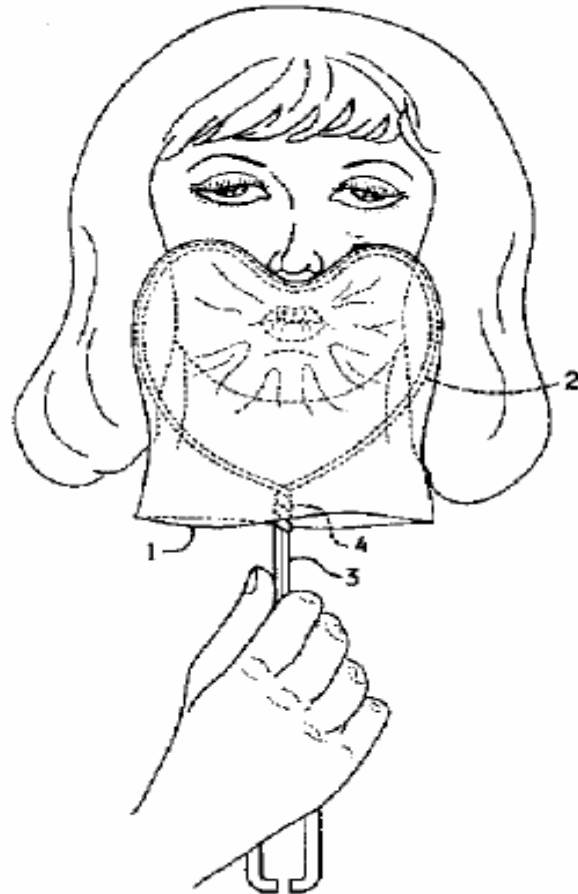

Abstract

A method of styling hair to cover partial baldness using only the hair on a person's head. The hair styling require dividing a person's hair into three sections and carefully folding one section over another.



FIG. 1



FIG. 2



FIG. 3



FIG. 4



FIG. 5



FIG. 6

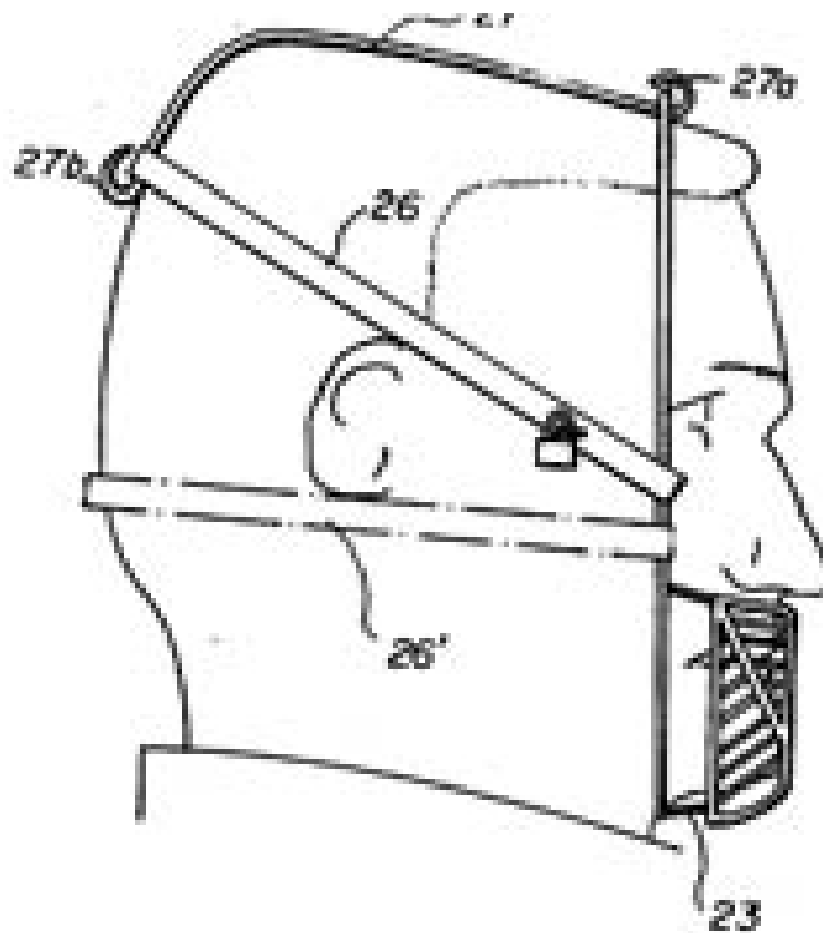

Objective of the patent system

- Back to basics:
 - The essential principles of patent law and policy
 - What is the system for?
 - How to make it work to achieve those goals?
- The system, based on private rights, should effectively serve the public interest (both right holders and society) by contributing to innovation and diffusion of knowledge
- It should thus both address the needs of society and produce benefits
- Fundamental features
 - Credible
 - timely grant and improved quality/validity of patents
 - Functional
 - rational use of resources
 - improved access to patent system, including access to patent information (costs)
 - Acceptable
 - accommodate different economic and social conditions and interests, without foreclosing further development

IP and Development: UK Study

“...prerequisite for sustainable development in any country is the development of an **indigenous scientific and technological capacity**. This is necessary to allow countries to develop their own process of technological innovation, and to enable them to absorb effectively technologies developed abroad...[..]...There are many other factors that contribute to what are often known as “national systems of innovation”. ..[..]...If intellectual property rights are to benefit developing countries, that benefit **will need to come through promoting invention and technological innovation**, and thereby enhancing growth.”

*UK Commission on Intellectual Property Rights, Integrating Intellectual Property Rights and Development Policy (2002)

The changing role of the patent system

From

- Protection and
- Exclusion

to

- Instrument serving innovation and technology diffusion
- Inclusiveness and cooperation
- Respect for diversity at various levels

The role of the patent system for innovation

Framework for:

- Providing incentives to invest, in particular, mobilizing resources into risky investments
- Preventing free-riding
- Promoting an efficient allocation of resources into innovation
- Specialization and shaping partnerships at various levels and supporting cumulative and shared innovation

Beware of:

- Abuse of patent rights, for example, on research tools
- Impediment to access important goods
- Non-practicing entities
- Cases of market failure

Innovation also changes

- Demand for IP rights has grown; more inventions and greater internationalization
- R&D expenditure is growing
- Innovation performance depends on broader investment in intangible assets
- Innovation is increasingly international in nature
- Innovation has become more collaborative and open in some respects

Areas of flexibility

Pre-grant:

- choice of what is patentable, and what is not
(*e.g. higher life forms, morality exceptions, medical treatments*)
- decision whether or not to seek a patent, and who applies
(*e.g. role of public sector institutions – Bayh-Dole*)

Post-grant:

- choice of how to exercise the patent
(*working the patent, what obligation to license?*)
- choice of scope or reach of patent rights
(*what kind of research exception, what reach of claims?*)
- choice of how to regulate the patent, once granted
(*compulsory licensing, government use*)

Main developments at WIPO: cooperation, respect for diversity, instrument

- Legal framework
 - Reform of the Patent Cooperation Treaty (PCT)
 - Patent Law Treaty (PLT)
 - Standing Committee on the Law of Patents (SCP)
- Practical projects
 - Infrastructure
 - Technology diffusion
- Policy issues
 - Global challenges
- Development Agenda

PCT Trends

- More countries: 146
- More applications: 4,5% decrease in 2009, but 5,7% increase in 2010 and 11% in 2011
- More ISAs: 17
- A definite trend towards increased worksharing based on international phase work
 - As proposed in Roadmap, consistent with vision of PCT founders
 - E.g. PPH-PCT
 - Etc.

Some PCT Challenges

- Trying to keep PCT from being politicized like other parts of WIPO's work
- Building trust between patent offices, so duplicative international phase and national phase processing can be reduced
- Quality of international work products
- Language issues
 - supplementary search and PatentScope™ tools
- Developing countries (“how can we realistically benefit from PCT?”)
 - Top 15 countries responsible for about 90% of IAs
 - Top 30 countries filed about 95% of IAs
 - The other 5% of filings are spread across over 110 countries

The Future of the PCT

- Higher quality PCT searches and examinations
 - via ISA/IPEA quality management efforts and increased emphasis on means for evaluating quality, 3rd party submissions, top-up searches, etc.
- PPH/PCT and its ramifications (and other incentives for applicants to resolve as much as possible within the international phase)
- More uniformity in application of PCT due to removal of incompatibilities with national law
- Continued focus on practical-level developments to enhance the PCT user experience (for example, PatentScope™ enhancements, etc.) and the PCT infrastructure as a platform for practical worksharing and accessing of relevant information
- Collaborative international search and examination

Patent Law Treaty (PLT)

- Concluded June 1, 2000
- Harmonizes and simplifies formal requirements for national and regional patent applications and patents. Excludes expressly substantive requirements of patentability
- Advantages: predictable, uniform and simple procedures for applications, reduction of costs
- Entered into force April 28, 2005, 32 Contracting Parties as of January 2013
- PLT Assembly: model international form and incorporation by reference of PCT changes

SCP: history

No agreement on the SCP work program; deadlock from 2006 - 2008

Proposal I (Developed countries)

- definition of prior art
- grace period
- novelty and inventive step

Proposal II (Group of Friends of Development)

- patentable subject matter
- exclusions from patentable subject matter
- exceptions to patent rights
- anti-competitive practices
- disclosure of origin, prior informed consent and benefit sharing
- effective mechanisms to challenge validity of patents
- sufficiency of disclosure of the invention
- transfer of technology
- safeguarding of public interest flexibility
- alternative models to promote innovation

Standing Committee on the Law of Patents (SCP):

- Member States' committee (IGOs and NGOs: observers)
- Forum to discuss issues, facilitate coordination and provide guidance concerning the progressive international development of patent law
- Forum that deals with clusters of issues rather than single issues in isolation

- Since 2000, discussions on the draft Substantive Patent Law Treaty (SPLT)
- No agreement on the SCP work program; deadlock from 2006 – 2008
- Currently working on a number tracks for the establishment of the work program

SCP: status of work

Working towards the establishment of a work program (since 2008)

- Report on the International Patent System (doc. SCP/12/3 Rev.2)
- Preliminary studies on selected issues:
 - exclusions from patentable subject matter and exceptions and limitations to the rights (document SCP/13/3)
 - patents and standards (document SCP/13/2)
 - client-patent attorney (patent advisor) privilege (documents SCP/13/4 and SCP/14/2)
 - dissemination of patent information (documents SCP/13/5 and SCP/14/3)
 - transfer of technology (documents SCP/14/4 and SCP/14/4 Rev.)
 - opposition systems (document SCP/14/5)
- 2010: agreement on five issues for future work

The five issues for discussion in the SCP

- Exceptions and limitations to patent rights
- Confidentiality of communications between patent advisors and their clients
- Transfer of technology
- Patents and health
- Quality of patents (including opposition systems)

IP Infrastructure

- Infrastructure Modernization
 - This program is intended to develop and strengthen national and regional IP offices through provision of modernization services
- International Classifications and the WIPO IP Standards.
 - These activities are intended to develop the Classifications as well as the WIPO IP Standards as common tools for facilitating the interchange and diffusion of IP information on global infrastructure
- The Global Information Services
 - This area aims to provide services on IP information search and retrieval from databases created within the global IP infrastructure and supporting services to IP Offices and the public including:
 - Access to Specialized Patent Databases;
 - Innovation Technology Support Centers (“TISCs” project);
 - Patent Landscaping project;
 - Digitization of national IP documents for dissemination through IP databases;
 - Patent Register Databases for Identifying patents in the public domain.

Patents and Technology Diffusion

- The patent system is generally understood to facilitate technology diffusion and investment; for some, it is even a prerequisite for technology transfer and investment abroad
- It does that mainly via
 - patent information and
 - by using patents as an instrument to assist technology transfer
- Several countries have in the past relied on the patent system as a tool in developing the national economy and this assisted it in promoting FDI and transfer of technology (e.g. Japan, Republic of Korea)
- Other countries also show a correlation:
 - India: FDI growth followed the patent reform in 1990s
 - Brazil: FDI growth followed the introduction of a new industrial property law in 1996 (US\$ 4.4 billion in 1995 to US\$ 32.8 billion in 2000)

University – industry collaboration

- Business is changing from closed research and development to more collaborative research with outside partners for competitive advantages
- Universities and research institutions are increasingly important partners, as they offer
 - Knowledge/technology creation
 - Adding-value through innovation
 - Skilled human resources
- Role of universities in economic development
 - Knowledge publication (research results etc.)
 - Types of cooperation: Technology licensing, spin-off companies, collaborative research, contract research, technology development, etc.
 - Increasing interest in cooperating with industry
- Benefits for both universities and industry

University – industry collaboration (ctd)

- To achieve a fruitful collaboration and technology transfer, universities need to manage IP and patents, in particular
- Patents are important for universities because
 - trade secrets are not sufficient
 - publication leads to public domain
 - Inventions of universities are often basic inventions and need improvements
 - universities can often not exploit inventions themselves, but have to license
- Partners from the private sector will request the existence of patent rights

The role of patents in certain global challenges, e.g. climate change, health

- Stimulus to invest into green innovation, as private sector investments are needed and occur in many cases because a functioning patent system allows successful innovators to earn an economic return on their investment.
- Contribute to a rapid and global diffusion of new technologies and knowledge, by making an invention a tradable good, which can be licensed or assigned, and by allowing to structure technology partnerships.
- Activities:
 - tools and services to enhance access to the relevant technologies
 - capacity building support for the management and transfer of green technologies
 - WIPO Green and WIPO Re:Search

WIPO Development Agenda

- All previously mentioned activities are now linked to the Development Agenda, the last session of the CDIP, November 22 to 26, 2010. Present seminar was also mandated by the CDIP
- Process started in 2004 (proposal from Brazil and Argentina, supported by some other developing countries).
- Finally, 45 recommendations discussed (19 ready for implementation, 26 to specify implementation)
- Project approach for the 26, partly individual, partly thematic approach
- CDIP adopted several projects, namely, the Project on Intellectual Property and Competition Policy, the Project on Intellectual Property, Information and Communication Technologies (ICTs) and the Digital Divide and Access to Knowledge, parts of the Project on Intellectual Property and the Public Domain and the Project on Developing Tools for Access to Patent Information
- Coordination Mechanisms

Thank you

philippe.baechtold@wipo.int