



# Seminario sui servizi e le iniziative dell'OMPI



**Brescia,  
10 Aprile, 2018**

# Un'introduzione all'OMPI e ai suoi principali studi economici sulla proprietà intellettuale



Mr. Giovanni Napolitano  
Director, Divisione PMI e sostegno all'imprenditorialità,  
Dipartimento dei paesi industrializzati e in transizione, OMPI

[giovanni.napolitano@wipo.int](mailto:giovanni.napolitano@wipo.int)

# WIPO

## MISSIONE

*“Promuovere  
innovazione e creatività  
attraverso lo sviluppo di  
un sistema di proprietà  
intellettuale (PI)  
equilibrato ed efficace, a  
vantaggio di tutti.”*

# Fatti su WIPO

- STATI MEMBRI: 189
- OSSERVATORI: + 390 (ONG, OIG, gruppi industriali, etc.)
- PERSONALE: ca. 1200
- TRATTATI AMMINISTRATI: 26
- PRINCIPALI ORGANI DIRETTIVI: Assemblee Generali, CC, Conferenza WIPO

# PRESENZA DELL'OMPI NEL MONDO



# Orientamento ai servizi e allo sviluppo

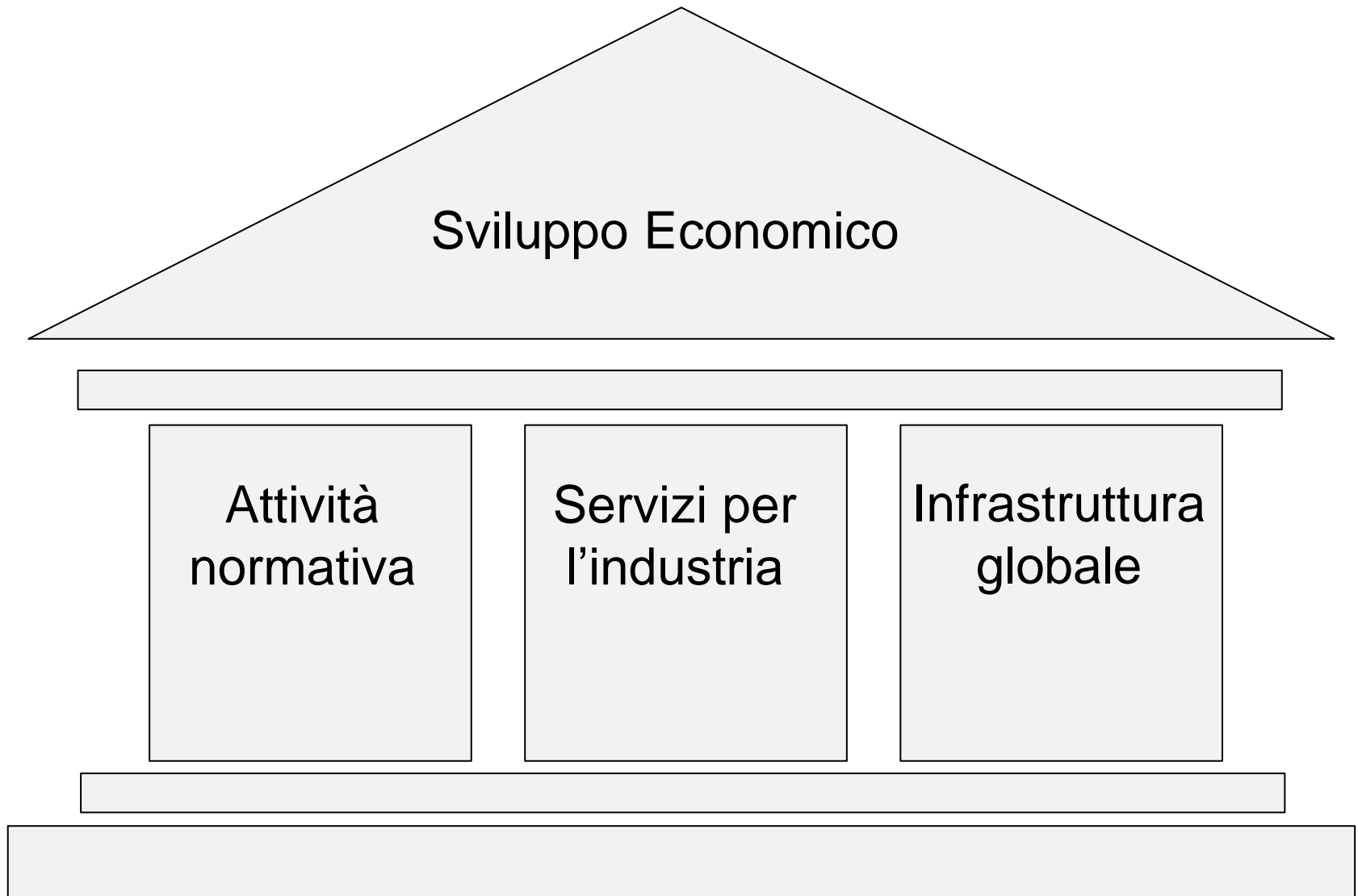

# 1. Sviluppi Normativi

- Trattato di Singapore sul Diritto dei Marchi (2006)
- Trattato di Marrakech Treaty per facilitare l'accesso ai testi pubblicati alle persone con incapacità visive



# 2. Servizi di punta a livello globale





# 3. Infrastruttura globale di PI

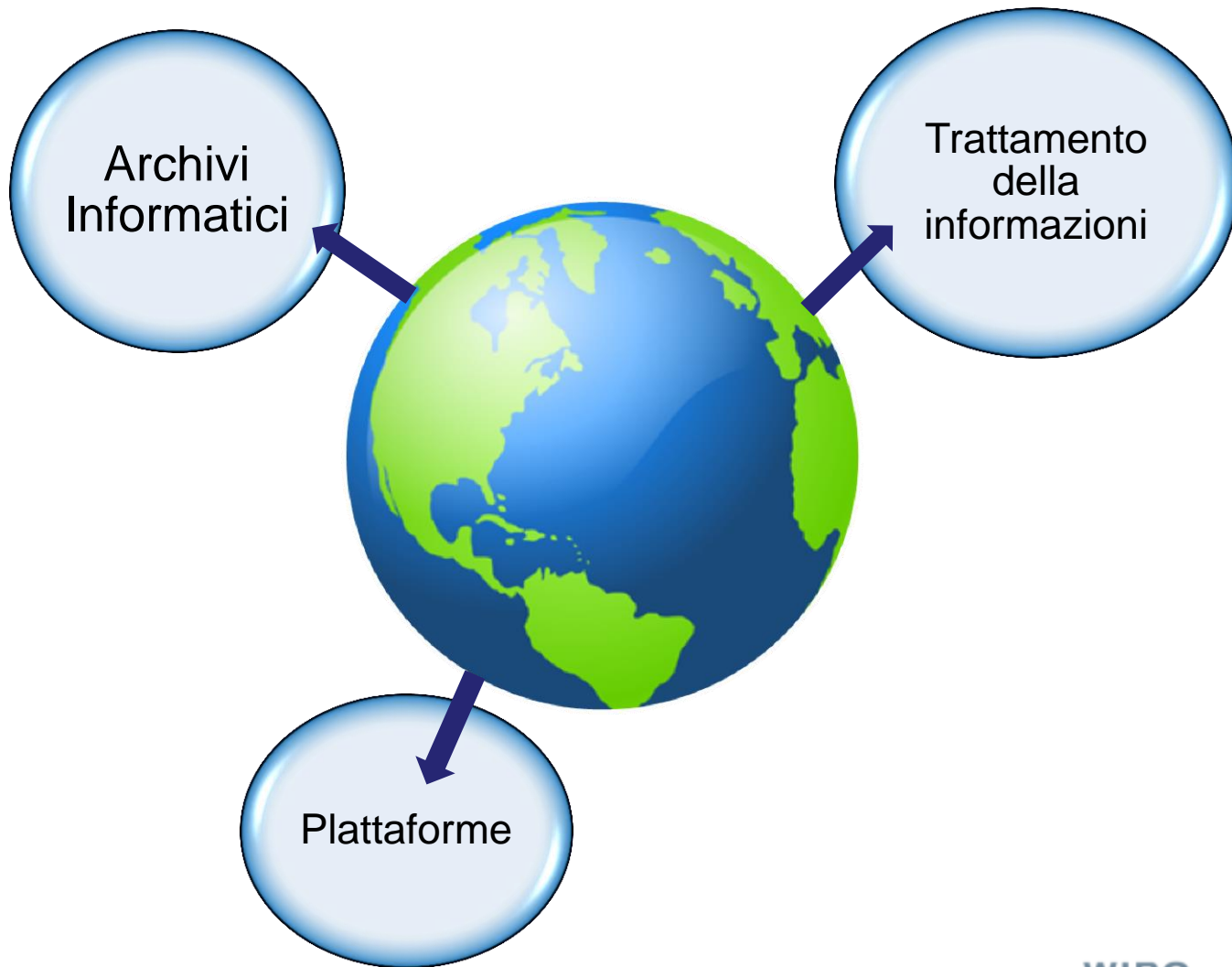

# Divisione Affari Economici e Statistici

La Divisione svolge analisi economica e statistica sull'utilizzo dei servizi dell'OMPI

**L'analisi riflette il crescente consenso sull'importanza degli aspetti economici della PI**

Questo approccio migliora anche l'analisi sullo sviluppo della PI in generale

# I principali studi economici sulla proprietà intellettuale

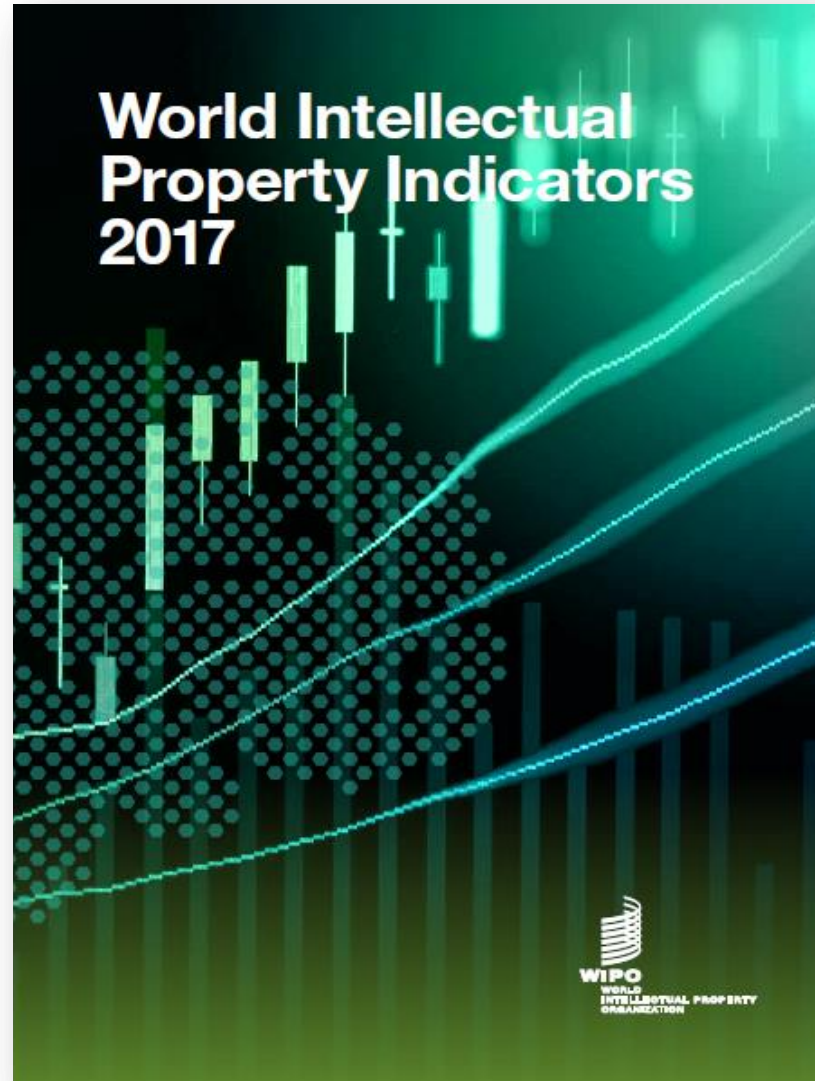

**WIPO**  
WORLD  
INTELLECTUAL PROPERTY  
ORGANIZATION

# I principali studi economici sulla proprietà intellettuale

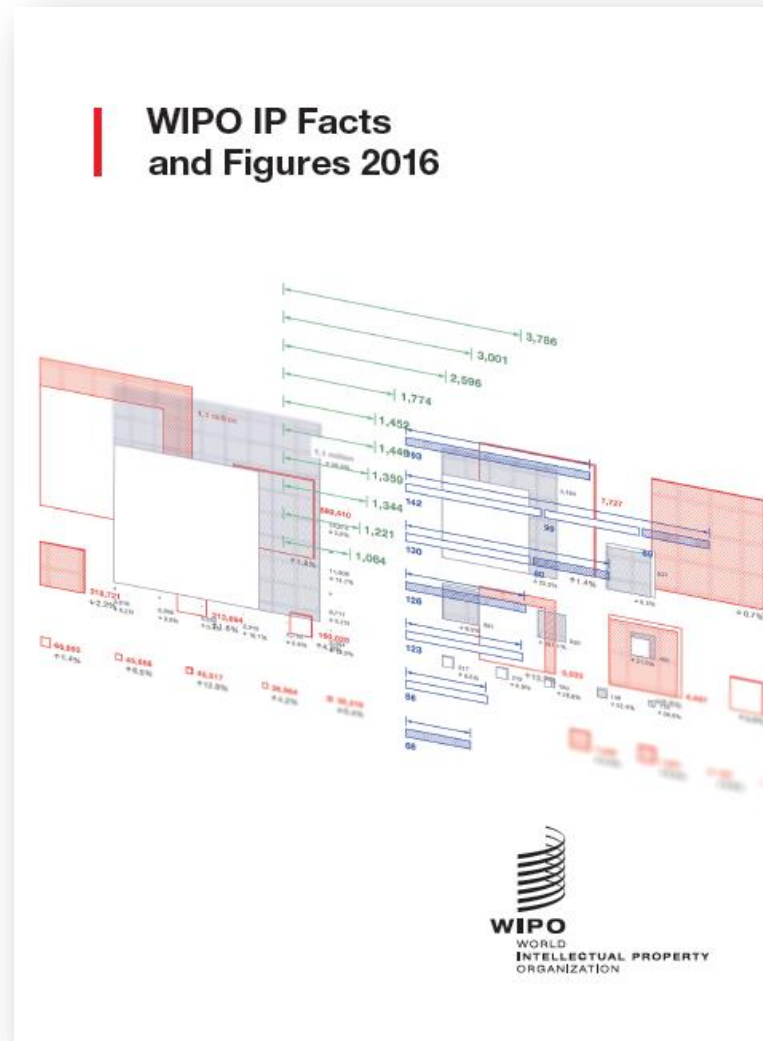

# I principali studi economici sulla proprietà intellettuale



# I principali studi economici sulla proprietà intellettuale

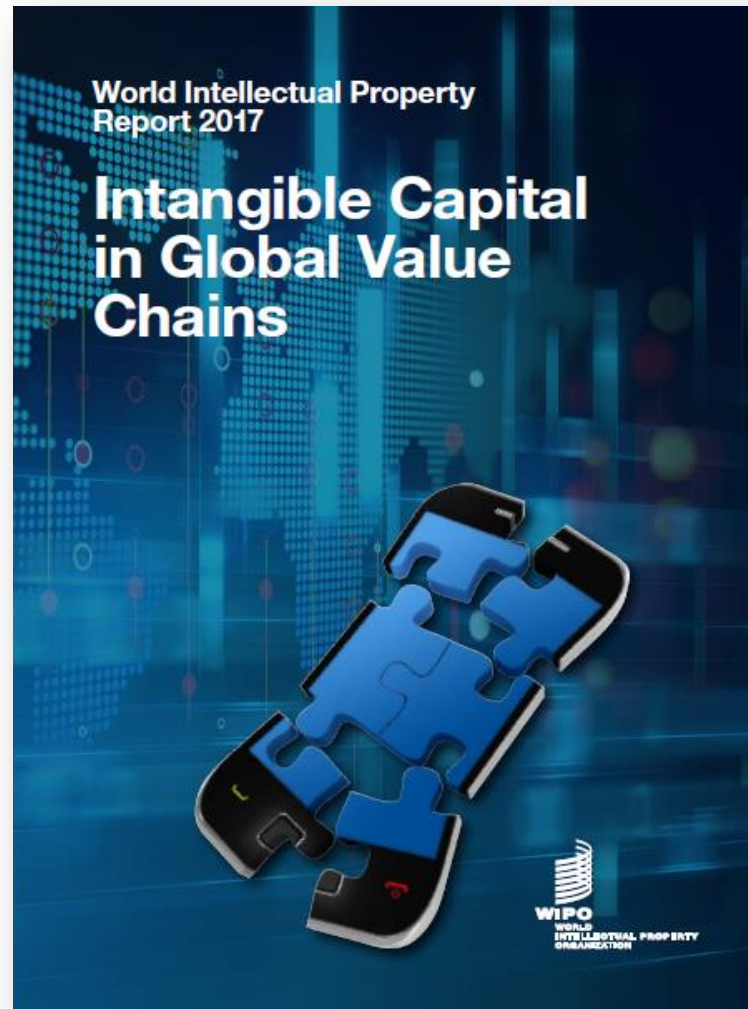

# Profilo paese



# L'indice « Global Innovation »

## Classifica 2016

1. SWITZERLAND
2. UNITED KINGDOM
3. SWEDEN
4. NETHERLANDS
5. UNITED STATES OF AMERICA
6. FINLAND
7. SINGAPORE
8. IRELAND
9. LUXEMBURG
10. DENMARK
11. HONG KONG (CHINA)
12. GERMANY
13. ICELAND
14. KOREA, REPUBLIC OF
15. NEW ZEALAND
- 29. ITALY**

## Classifica 2017

1. SWITZERLAND
2. SWEDEN
3. UNITED KINGDOM
4. UNITED STATES OF AMERICA
5. FINLAND
6. SINGAPORE
7. IRELAND
8. DENMARK
9. NETHERLANDS
10. GERMANY
11. KOREA, REPUBLIC OF
12. LUXEMBOURG
13. ICELAND
14. HONG KONG (CHINA)
15. CANADA
- 29. ITALY**



	Strengths	Challenges
<b>Institutions</b>	1. Cost of redundancy dismissal, salary weeks	
<b>Human capital &amp; research</b>	2. Global R&D companies	1. Expenditure on education
<b>Infrastructure</b>	3. Government's online service 4. E-participation 5. ISO 14001 environmental certificates	
<b>Market sophistication</b>	6. Domestic market scale	2. Ease of getting credit 3. Market capitalization
<b>Business sophistication</b>	7. State of cluster development	4. Females employed w/advanced degrees 5. JV–strategic alliance
<b>Knowledge &amp; technology outputs</b>	8. Citable documents H index 9. Computer software spending 10. ISO 9001 quality certificates/	6. Growth rate of PPP\$ GDP/worker
<b>Creative outputs</b>	11. Industrial designs by origin	7. ICTs & organizational model creation

# Uno sguardo alle statistiche

- Le domande di brevetto sono cresciute di circa il 2,6% tra il 2007 and il 2014\*
- Le domande di marchi sono cresciute di circa il 29% tra il 2009 e il 2014 \*
- Le domande di disegno industriale sono cresciute di circa il 27% tra il 2008 e il 2014 \*

## Domande titoli PI e crescita economica dal 2000 al 2015

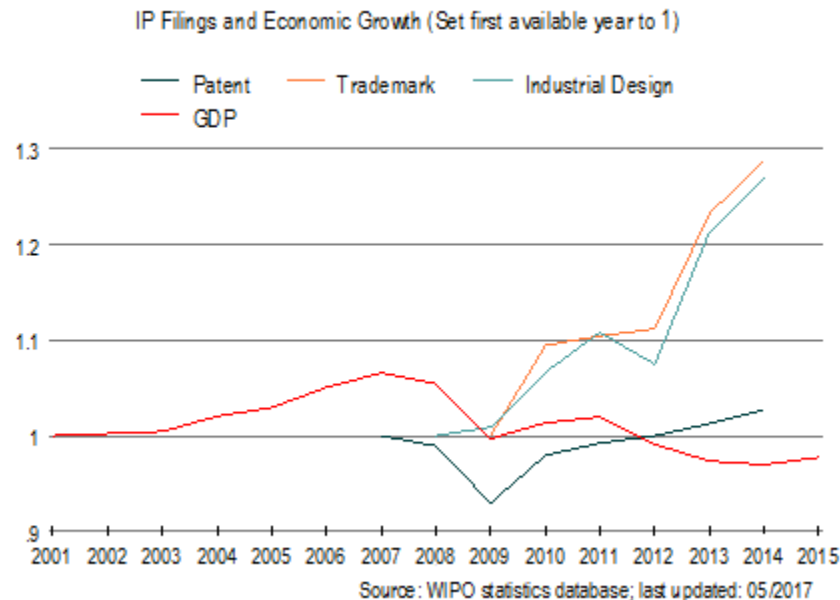

# Domande italiane attraverso servizi OMPI

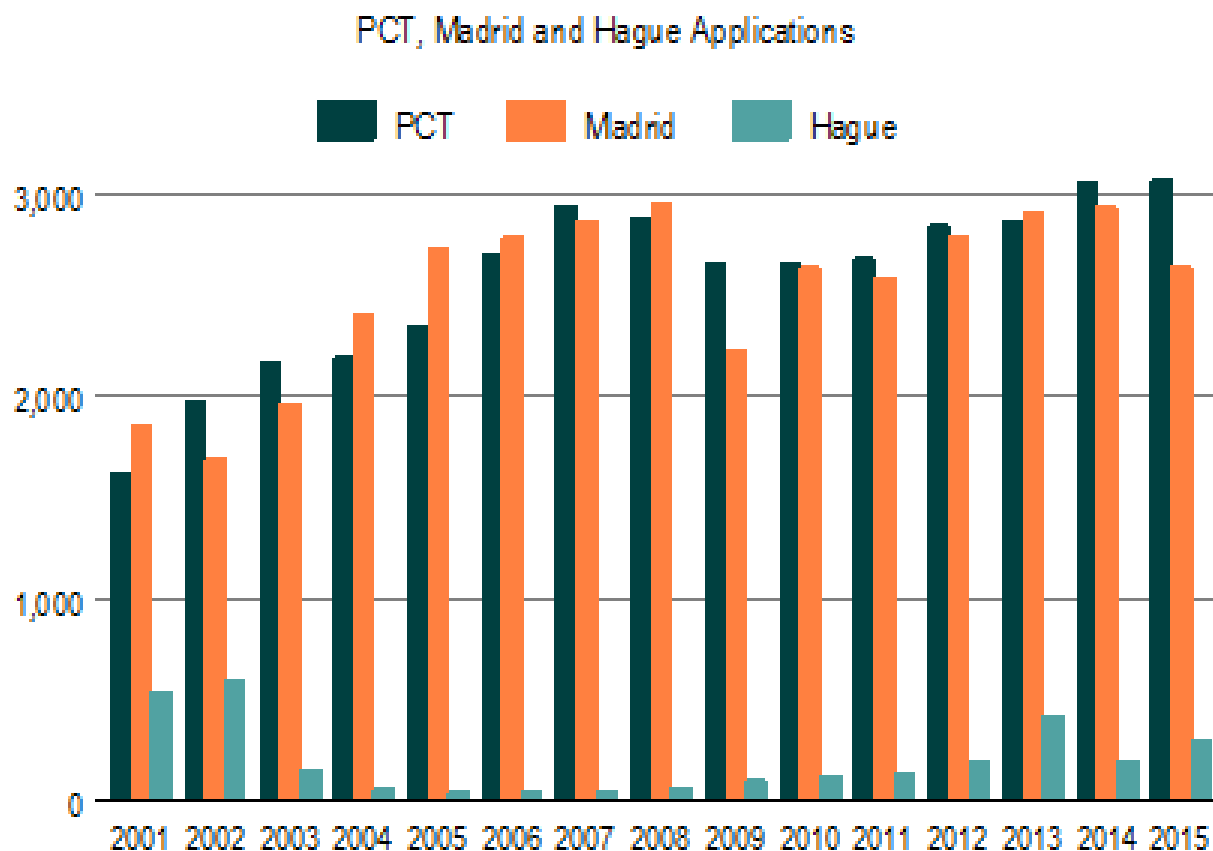

Source: WIPO statistics database; last updated: 05/2017

# Conclusioni

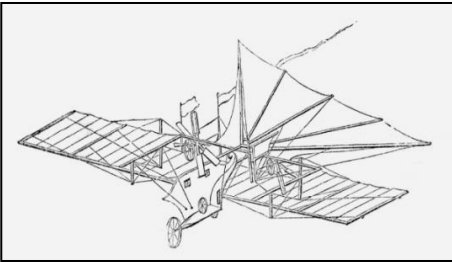

**PCT (Brevetti)**



**Madrid (Marchi)**



**I'Aja (Disegni industriali)**

# Seguiteci su:

- Twitter: [@wipo](https://twitter.com/wipo)
- WIPO Magazine  
[www.wipo.int/wipo\\_magazine/e](http://www.wipo.int/wipo_magazine/e)
- WIPO Wire:  
[www.wipo.int/newsletters/en](http://www.wipo.int/newsletters/en)
- Comunicati stampa  
[www.wipo.int/pressroom/en/](http://www.wipo.int/pressroom/en/)







# The Patent Cooperation Treaty (PCT): Introduction and Future Developments



Ms. Silke Weiss, Program Officer  
PCT Legal Division, WIPO

**Brescia, Italy, April 10, 2018**

# Topics

- Invention and Patent
- Introduction to the PCT System
- PCT Procedure
- Advantages of the PCT System
- Contracting States
- Statistics
- Information and Training





# **Invention and Patent**

# Invention - Patent



## ■ Invention:

- In general: a new technical solution to a problem
- More specific:
  - a product or process, which is
  - novel,
  - involves an inventive step (non-obvious), and
  - is industrially applicable (useful).

## ■ Patent:

It consists of a set of exclusive rights granted by a sovereign state for an invention.

- Territorial right
- Protection for a limited period (usually 20 years from the filing date)
- Exclusive right to prevent others from making, using, selling, distributing or importing the invention without the patent owner's consent





# **Introduction to the PCT System**

# Traditional Patent System under the Paris Convention

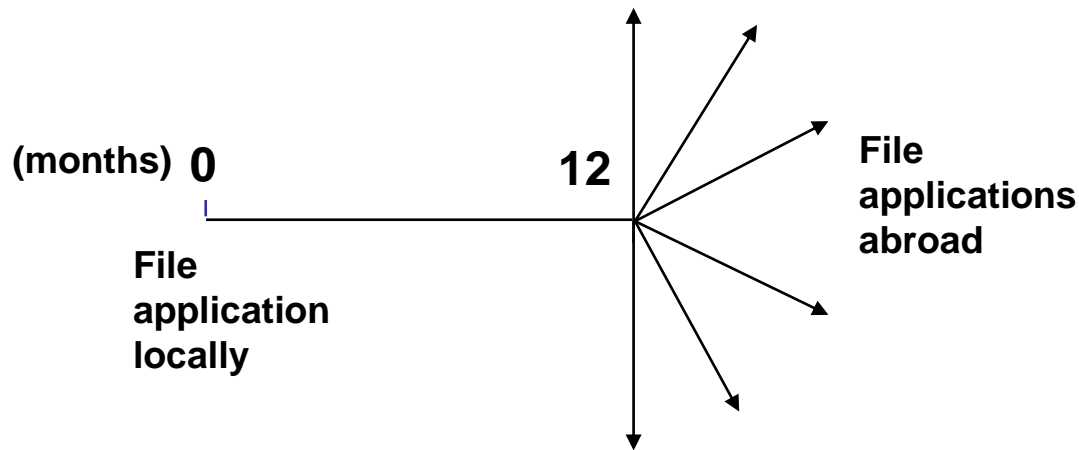

- Local patent application followed within 12 months by multiple foreign applications claiming priority under the Paris Convention (1883)
- Multiple formality requirements, searches, publications, examinations, prosecutions
- Translations and national fees at 12 months

# What is the PCT?



- An international treaty facilitating the process of seeking patent protection internationally
- An efficient and advantageous simplify procedure for obtaining patent protection in many countries
- Signed in June 1970 and became operational in June 1978 with 18 Contracting States
  - Entered into force in Italy on March 28, 1985
- Currently 152 Contracting States

# 40 Years of the PCT

- 24 January 2018: 40th anniversary of the entry into force of the Patent Cooperation Treaty (PCT)

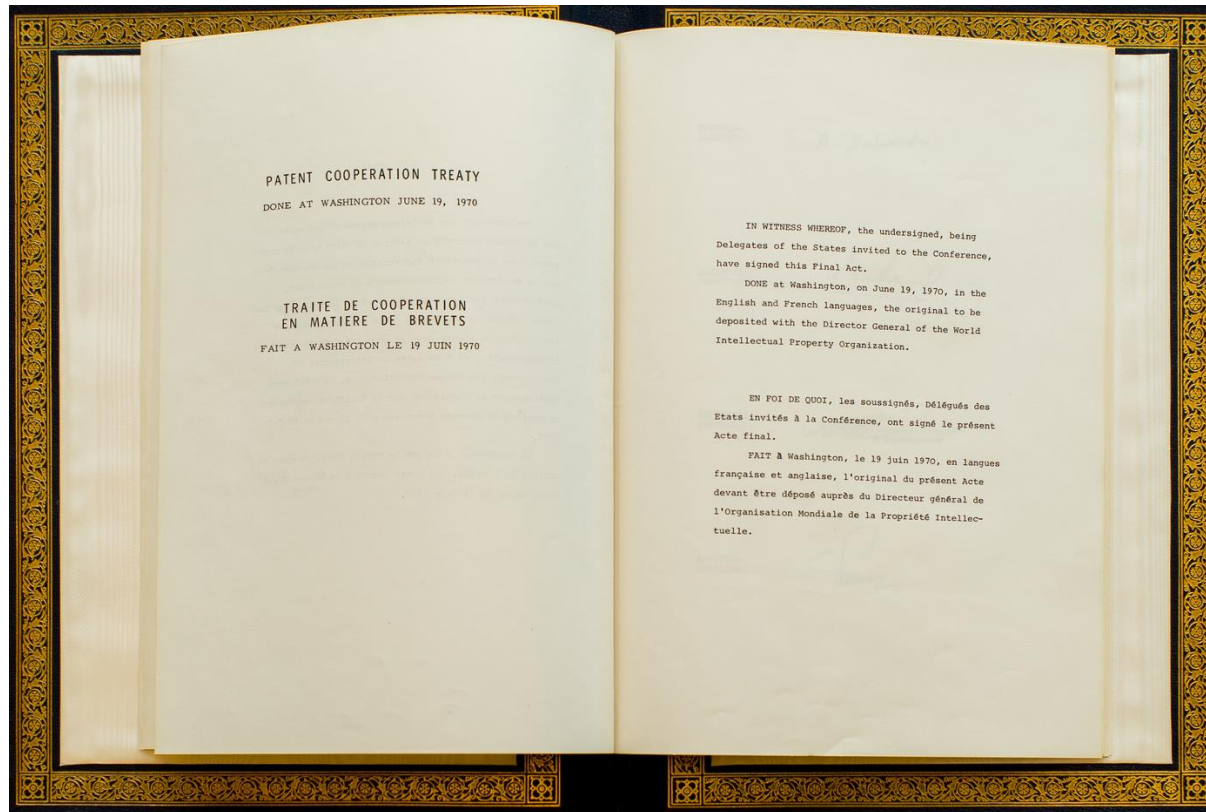

# Putting Innovation into Practice

- The PCT is a global solution for the world's innovator
  - One international patent application
  - One form
  - One language
  - One office
  - One set of fees
- Has the effect of a regular national filing in each Member State



# Traditional Patent System vs. PCT System

Fees for:  
 - translations  
 - Office fees  
 - local agents

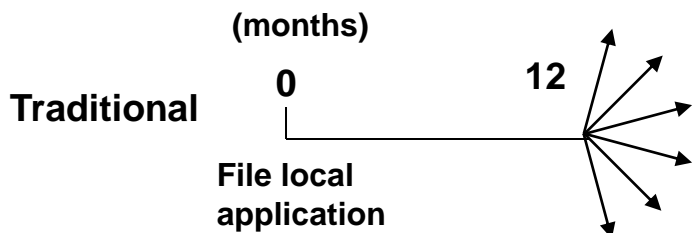

Fees for:  
 - translations  
 - Office fees  
 - local agents

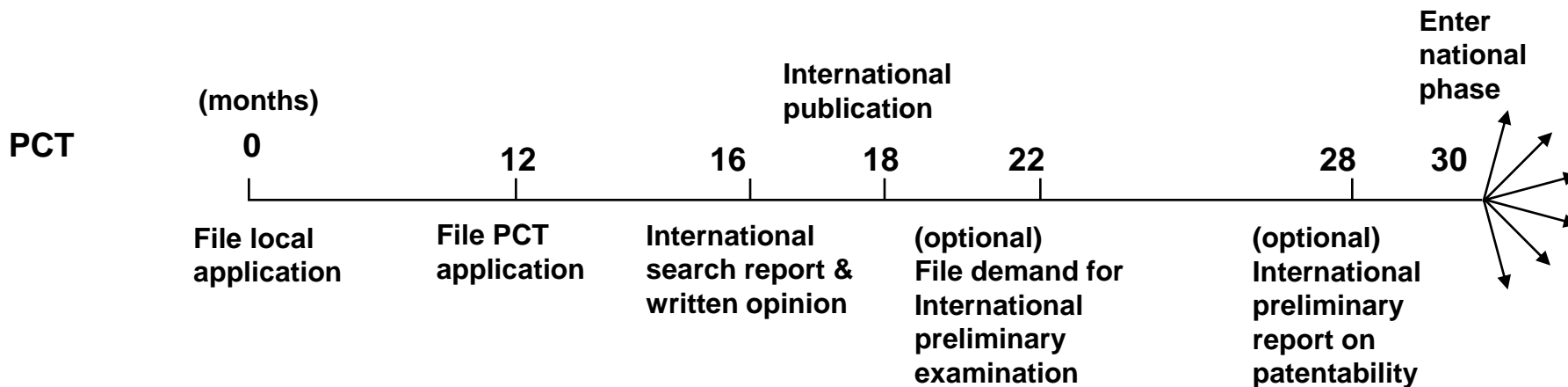

# General remarks on the PCT system (1)

- Only inventions may be protected via the PCT
- The PCT system is a patent “filing” system, not a patent “granting” system. There is no “PCT patent”
- The decision on granting patents is taken exclusively by national or regional Offices in the national phase



# General remarks on the PCT System (2)

- The PCT system provides for
  - an international phase comprising:
    - filing of the international application
    - international search and written opinion of the ISA
    - international publication
  - a national/regional phase before designated Offices



# PCT Procedure

# Overview of the PCT system

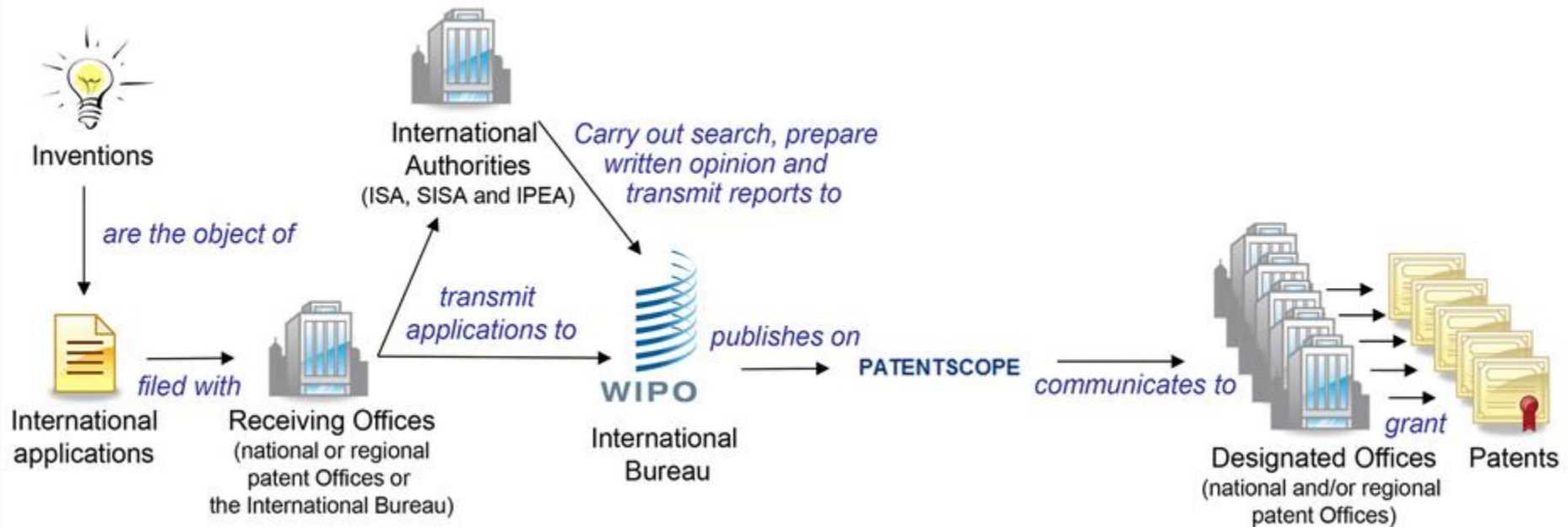

# The PCT System

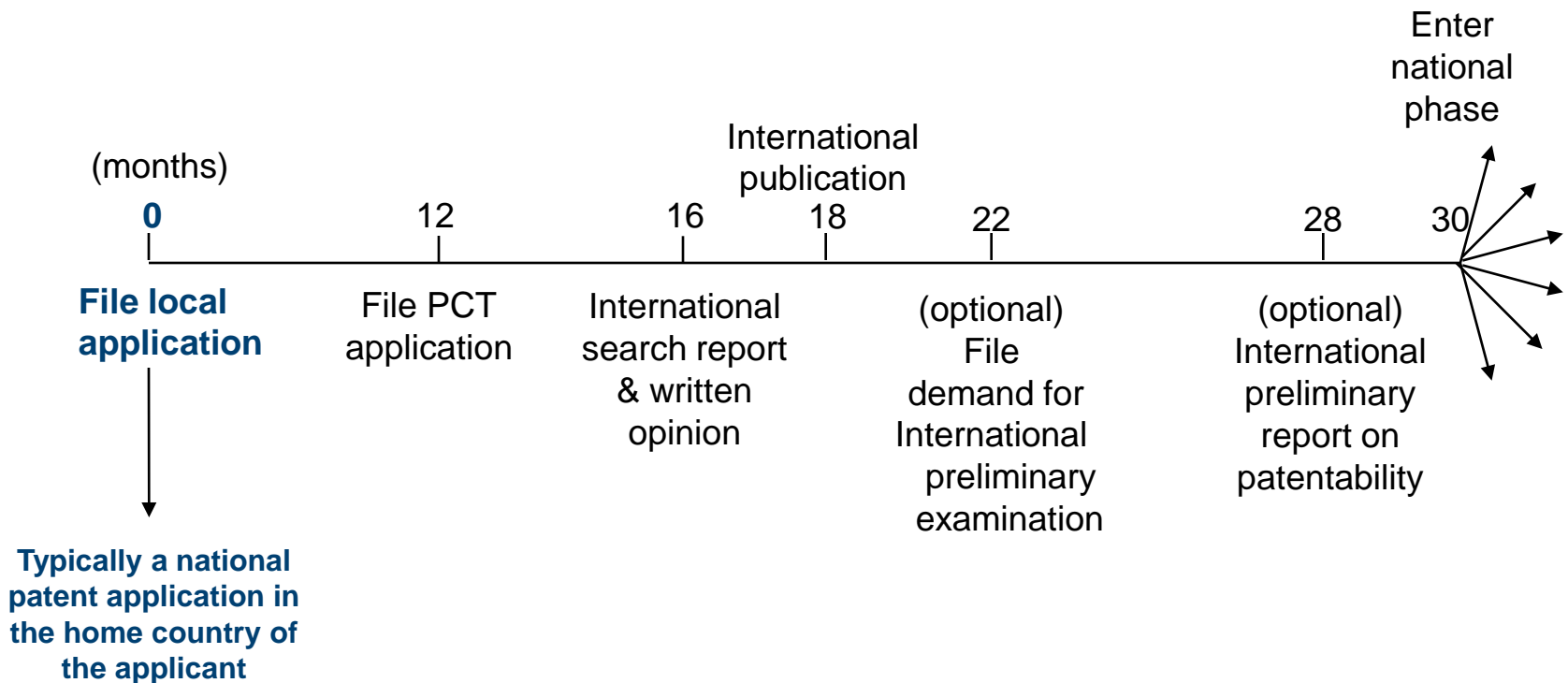

# The PCT System

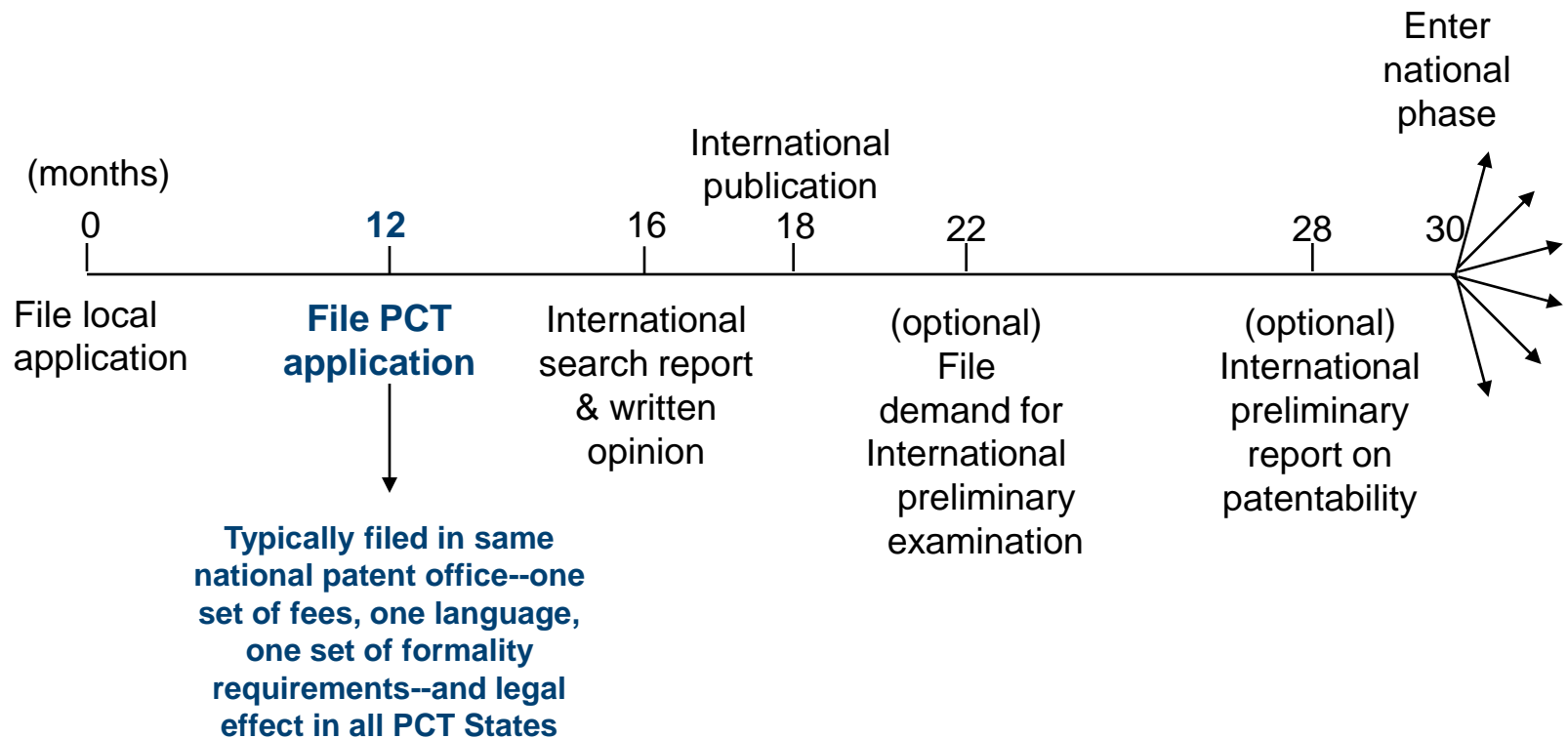

# Where to file the PCT application

- Competent receiving Office depends on the nationality and residence of the applicant(s)
  - With a national Office
  - With a regional Office
  - With the International Bureau of WIPO

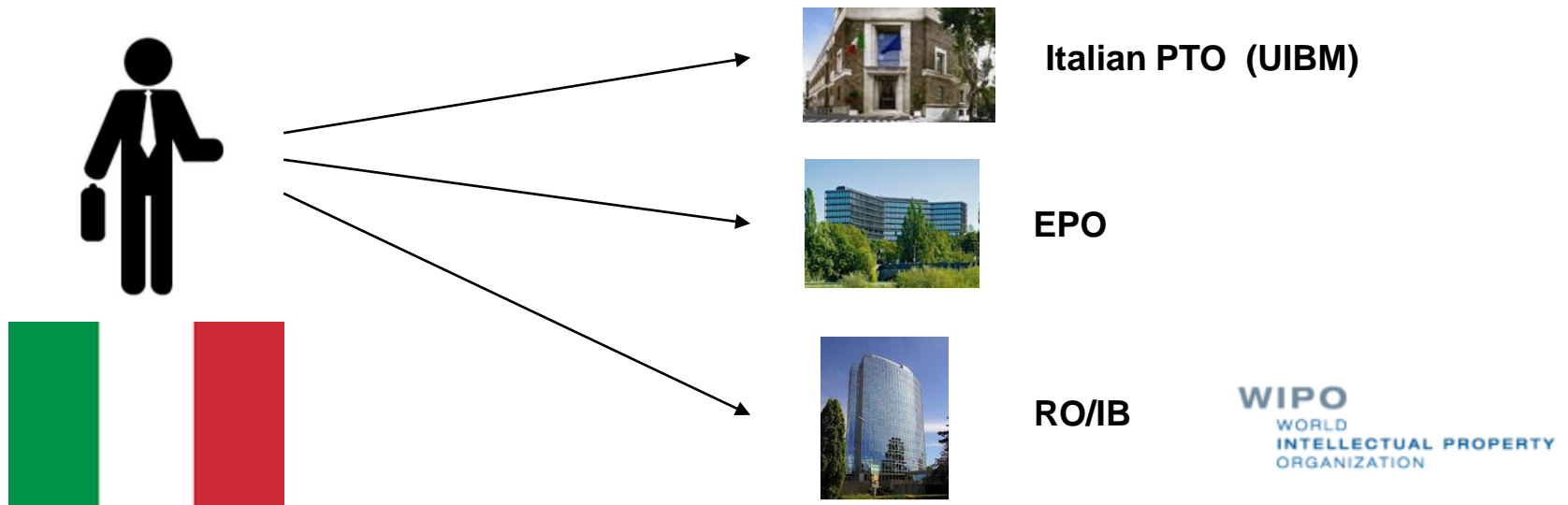



# The Italian Receiving Office

- Applicants:
  - Nationals and residents of Italy
- Accepted languages:
  - English, French, German or Italian (request in English, French or German)
- Fees:
  - Transmittal fee: EUR 33,99
  - International filing fee: EUR 1,163

# What does a PCT application contain?

- Request (petition to be processed according to the PCT)
- Description (discloses the invention)
- One or more claims (define the matter)
- Drawings (where necessary) (illustrates invention)
- Abstract (summary of the disclosure)

# Content of a PCT application

## Request

PCT

REQUEST

The undersigned requests that the present international application be processed according to the Patent Cooperation Treaty.

For receiving Office use only
International Application No.
International Filing Date
Name of receiving Office and "PCT International Application"
Applicant's or agent's file reference (if desired) (12 characters maximum)

## Description

DESCRIPTION

Technical field and prior art

The invention relates to an ultra-rapid aerial vehicle and to an aerial locomotion method using an aerial vehicle in accordance with the aerial vehicle of the invention.

Studies on the point-to-point ultrafast transport theme have been recently used in Japan and United States. In the wake of these initiatives, EDS and ASTRIUM are also performing, of the ASP program (ASP) of the ASP PLASTRIUM SPACE PLAY), concept surveys for a point-to-point ultra-rapid aerial vehicle.

## Claims

1. The aerial vehicle comprises a fuselage (F), a gothic delta wing (A) distributed on both sides of the fuselage and a system of engines (TB1, TB2, ST1, ST2, Mf) capable of propelling the aerial vehicle, characterized in that

The fuselage contains a reservoir (Rv) liquid hydrogen or molten snow state and one or more liquid oxygen reservoirs (ROI, R02);

## Abstract

(EN)The invention relates to an ultra-rapid air vehicle and to a method for aerial locomotion provided by an ultra-rapid air vehicle. The air vehicle is propelled by an engine system consisting of jet engines (TB1, TB2), ramjet engines (ST1, ST2), and a streamlinable rocket engine for reducing the base drag in cruise phase. The air vehicle has a gothic delta wing (A) provided with winglets (a1, a2) that are movable to the two outer ends of the trailing edge of the delta wing (A).

## Drawings

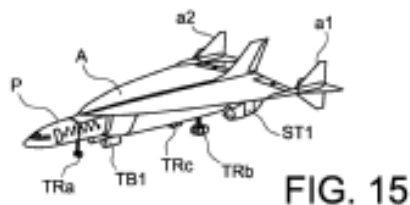

# The PCT System

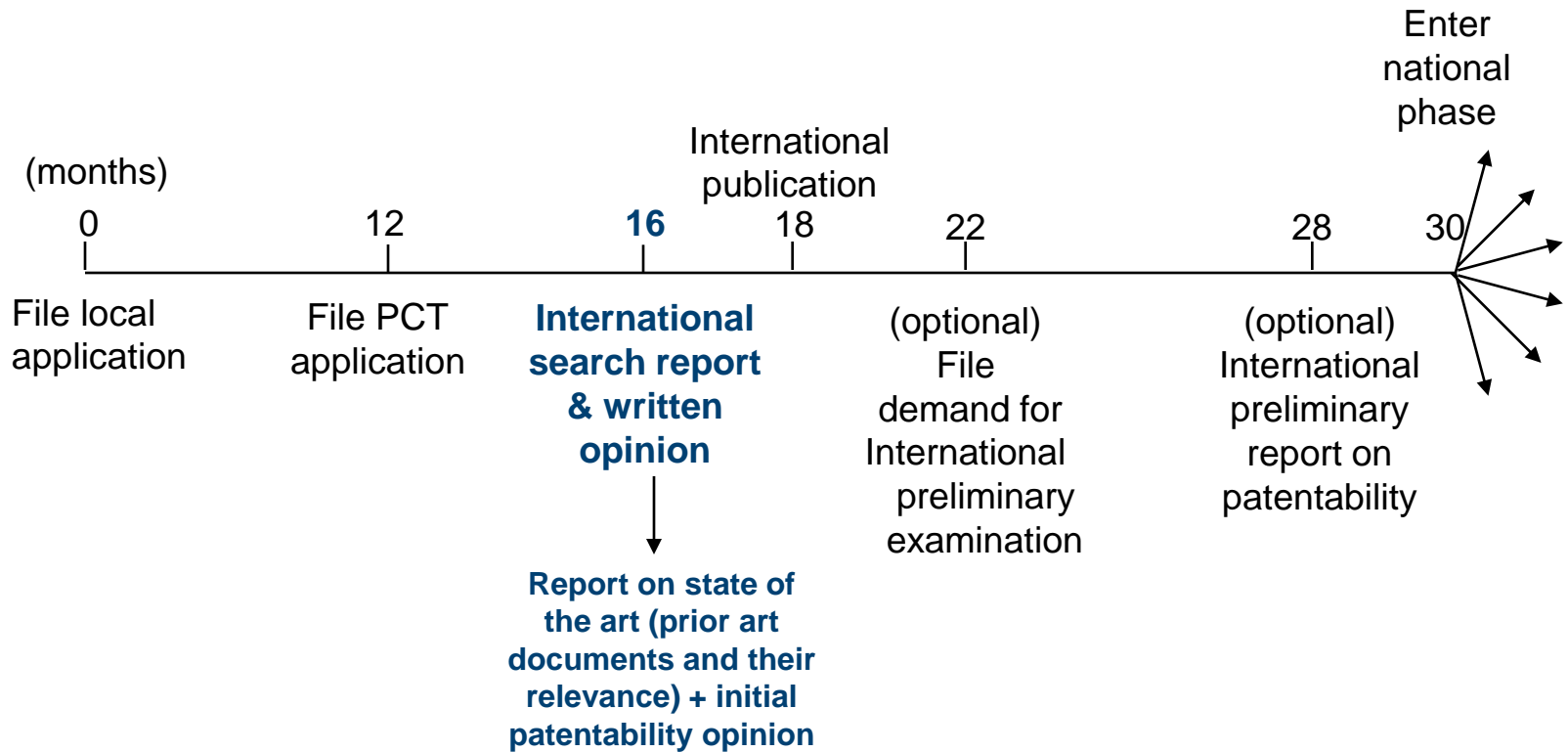

**Helps applicant to know whether he is likely to obtain a patent**

# PCT International Searching Authorities

The ISAs are the following 23 offices:

Australia	Japan
Austria	Nordic Patent Institute
Brazil	Republic of Korea
Canada	Russian Federation
Chile	Singapore
China	Spain
Egypt	Sweden
European Patent Office	Turkey
Finland	Ukraine
India	United States of America
Israel	Visegrad Patent Institute

PCT Assembly 2017:

Appointment of the Intellectual Property Office of the Philippines as PCT ISA/IPEA (not yet operational)

# Example of an ISR

C. DOCUMENTS CONSIDERED TO BE RELEVANT		
Category*	Citation of document, with indication, where appropriate, of the relevant passages	Relevant to claim No.
X	JP 50-14535 B (NCR CORPORATION) 28 May 1975 (28.05.75), column 4, lines 3 to 27	7-9, 11
X	GB 392415 A (JONES) 18 May 1933 (18.05.33) Fig. 1	1-3
Y		4, 10
A		11-12
X	GB 2174500 A (STC) 5 November 1986 (05.11.86) page 1, lines 5-15, 22-34, 46-80; Fig. 1	1-3
Y		4
A	US 4322752 A (BIXTY) 30 March 1982 (30.03.82) claim 1	1
A	GREEN, J.P. Integrated Circuit and Electronic IBM Technical Disclosure Bulletin Vol. 17, No. 6, page	1-5

Symbols indicating the relevance of the cited prior art to the patentability of the international application (for example, novelty, inventive step, etc.)

Documents relevant to whether or not your invention may be patentable

The claim numbers in your application to which the document is relevant

# Example of the Written Opinion

WRITTEN OPINION OF THE INTERNATIONAL SEARCHING AUTHORITY		International application No.
<b>Box No. V Reasoned statement under Rule 43bis.1(a)(i) with regard to novelty, inventive step or industrial applicability; citations and explanations supporting such statement</b>		
1. Statement		
Novelty (N)	Claims	<u>Claim(s) 3-15</u> YES
	Claims	<u>Claim(s) 16</u> NO
Inventive step (IS)	Claims	<u>Claim(s) 8, 10-12</u> YES
	Claims	<u>Claim(s) 3-7, 9, 14-16</u> NO
Industrial applicability (IA)	Claims	<u>Claim(s) 3-16</u> YES
	Claims	_____ NO
2. Citations and explanations:		
<b>INDEPENDENT CLAIM 3</b>		
Document US-A-5 332 238, which is considered to represent the most relevant state of the art, discloses (cf. relevant passages indicated in the ISR) a device from which the subject-matter of <b>INDEPENDENT CLAIM 3</b>		
Document US-A-5 332 238, which is considered to represent the most relevant state of the art,		

**Patentability  
assessment  
of the claims**

**Reasoning  
supporting the  
assessment**

# The PCT System

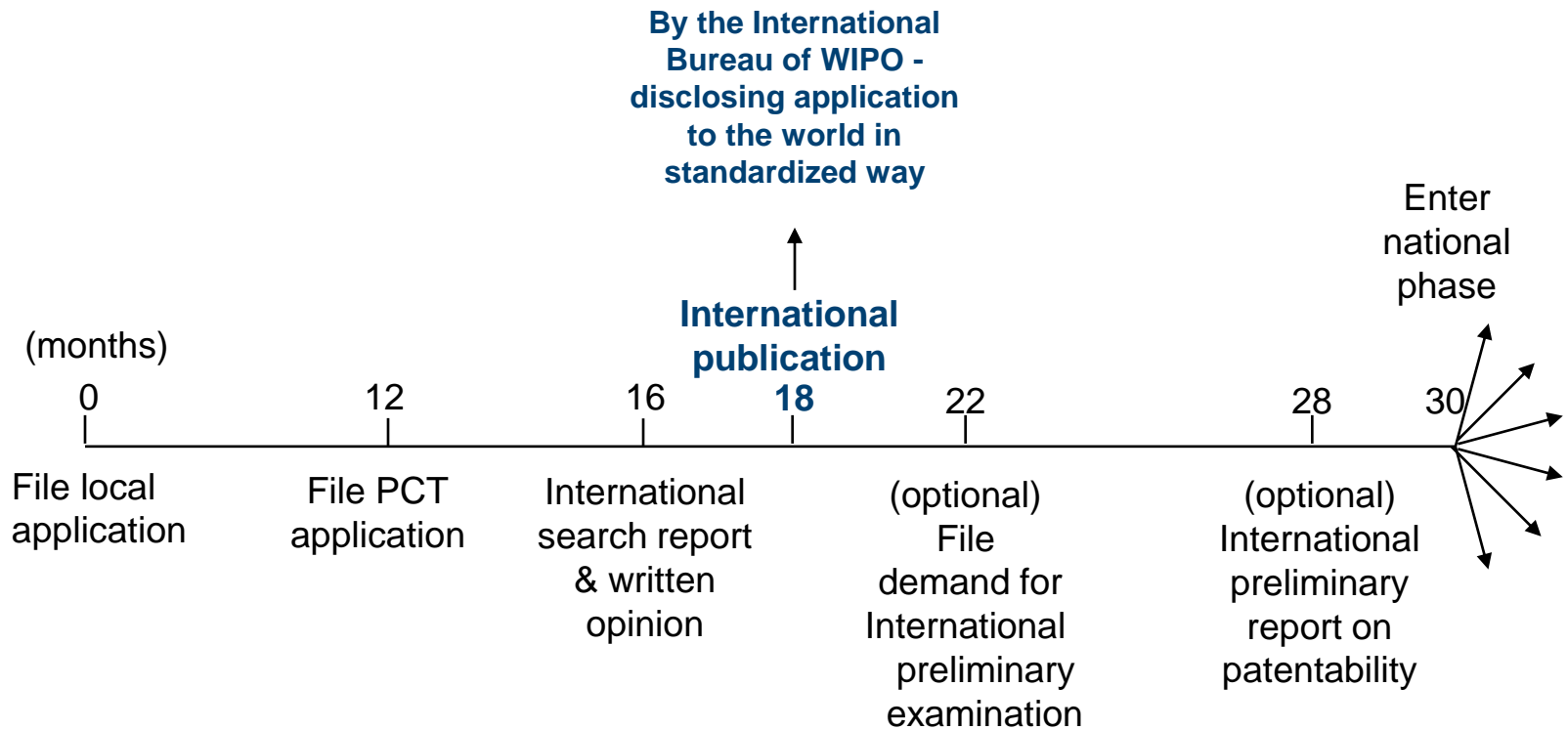



# Ultra-rapid air vehicle (WO2011076706)

PCT Biblio. Data Description Claims National Phase Notices Drawings Documents

Latest bibliographic data on file with the International Bureau

PermaLink 

**Pub. No.:** WO/2011/076706 **International Application No.:** PCT/EP2010/070189  
**Publication Date:** 30.06.2011 **International Filing Date:** 20.12.2010  
**IPC:** B64C 30/00 (2006.01), B64C 5/08 (2006.01), B64C 5/10 (2006.01) 

**Applicants:** **ASTRIUM SAS** [FR/FR]; 6 rue Laurent Pichat F-75016 Paris (FR) *(For All Designated States Except US)*.  
**EUROPEAN AERONAUTIC DEFENCE AND SPACE COMPANY - EADS FRANCE** [FR/FR]; 37, boulevard de Montmorency F-75016 Paris (FR) *(For All Designated States Except US)*.  
**PRAMPOLINI, Marco** [FR/FR]; (FR) *(For US Only)*.  
**CORABOEUF, Yohann** [FR/FR]; (FR) *(For US Only)*

**Inventors:** **PRAMPOLINI, Marco**; (FR).  
**CORABOEUF, Yohann**; (FR)

**Agent:** **ILGART, Jean-Christophe**; Brevalet 95, rue d'Amsterdam F-75378 Paris Cedex 8 (FR)

**Priority Data:** 09 59366 22.12.2009 FR

**Title** (EN) ULTRA-RAPID AIR VEHICLE AND RELATED METHOD FOR AERIAL LOCOMOTION  
(FR) VEHICULE AERIEN ULTRA-RAPIDE ET PROCEDE DE LOCOMOTION AERIENNE ASSOCIE

**Abstract:** (EN)The invention relates to an ultra-rapid air vehicle and to a method for aerial locomotion provided by an ultra-rapid air vehicle. The air vehicle is propelled by an engine system consisting of jet engines (TB1, TB2), ramjet engines (ST1, ST2), and a streamlinable rocket engine for reducing the base drag in cruise phase. The air vehicle has a gothic delta wing (A) provided with winglets (a1, a2) that are movable to the two outer ends of the trailing edge of the delta wing (A).

(FR)L'invention concerne un véhicule aérien ultra-rapide ainsi qu'un procédé de locomotion aérienne assuré par un véhicule aérien ultra-rapide, le véhicule aérien étant propulsé par un système de moteurs formé de turboréacteurs (TB1, TB2), de statoréacteurs (ST1, ST2) et d'un moteur fusée carénable pour réduire la traînée de culot en phase de croisière, le véhicule aérien ayant une aile delta gothique (A) muni d'ailettes (a1, a2) mobiles aux deux extrémités extérieures du bord de fuite de l'aile delta (A).

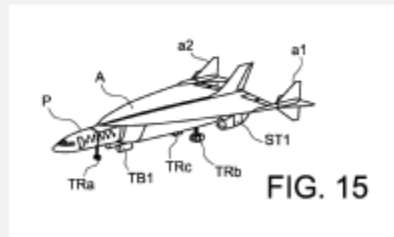
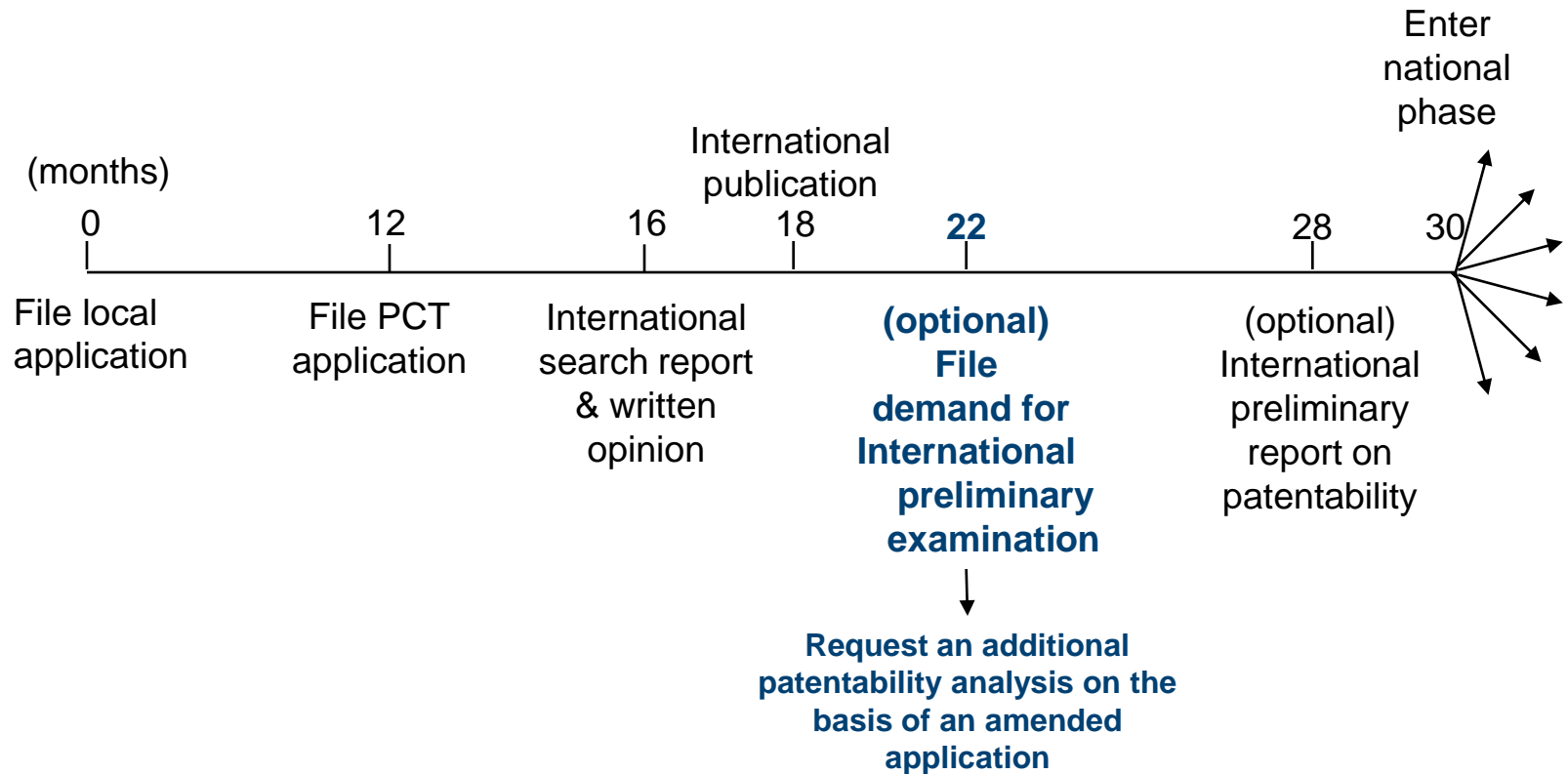

FIG. 15

International Business Times (4/8/2015):  
 “Airbus patents hypersonic jet that could finish London-New York trip in 1 hour”

The jet could travel at 4.5 times the speed of sound, fly at an altitude of 30,000 m.

# The PCT System



**Allows applicant to correct defects or refute arguments in written opinion**

# The PCT System

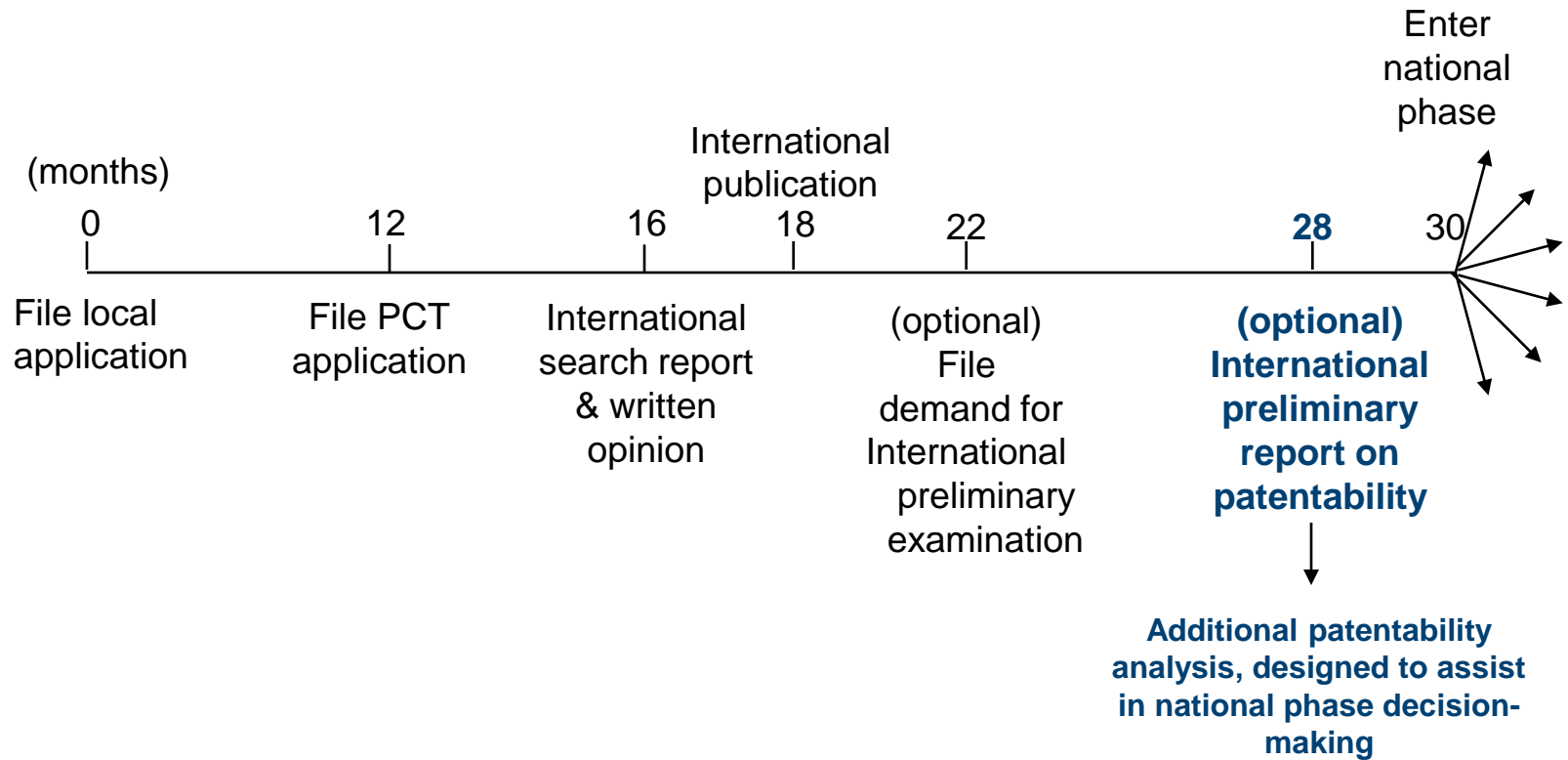

# The PCT System

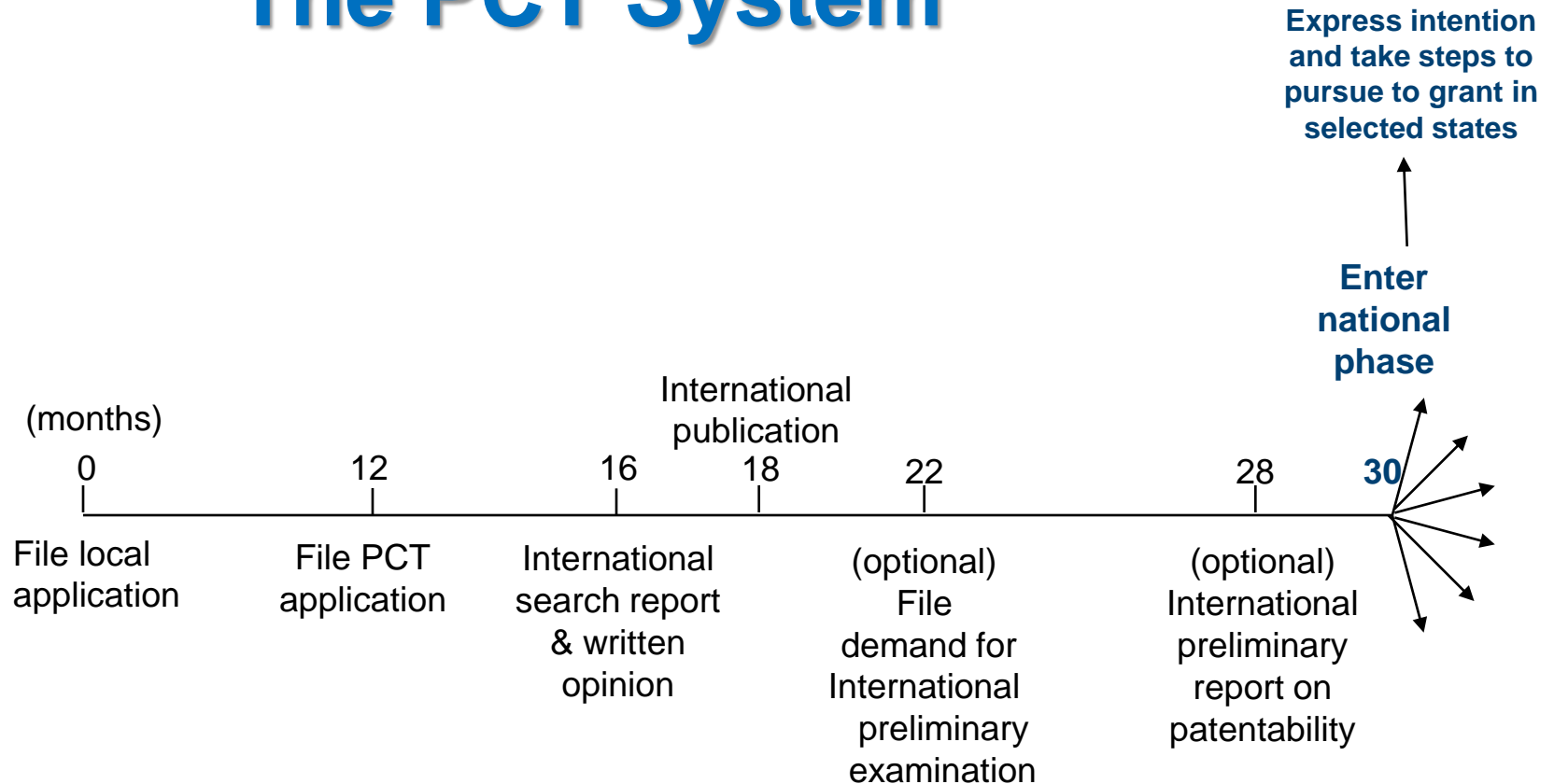

# Decisions to be taken by the applicant

- Whether
  - to proceed with or drop the international application ?
- When
  - At the end of 30 months (in some cases 31 or more)
  - Early entry ?
- Where (choice limited to designated/elected Offices
  - which national Office
  - which regional Office
- Grant (or refusal) of a patent by national or regional Offices



# **Advantages of the PCT System**

# Summary of the Advantages

The PCT, as the cornerstone of the international patent system, provides a worldwide system for simplified filing and processing of patent applications, which

1. Brings the world within reach (“Internationalization” of a single PCT application providing near global geographical coverage)
2. Time delay (additional time for decision)
3. Cost deferral (postpones the major costs associated with seeking multinational patent protection:
  - cost of translations
  - local patent agent fees
  - local patent Office fees
4. Patentability assessment (provides a strong basis for patenting decisions)
5. Harmonizes formal requirements
6. Protects applicants from certain inadvertent errors
7. Avoiding errors and fee reduction through possibility of electronic filing



# Contracting States



# The PCT in 1978 – 18 Member States

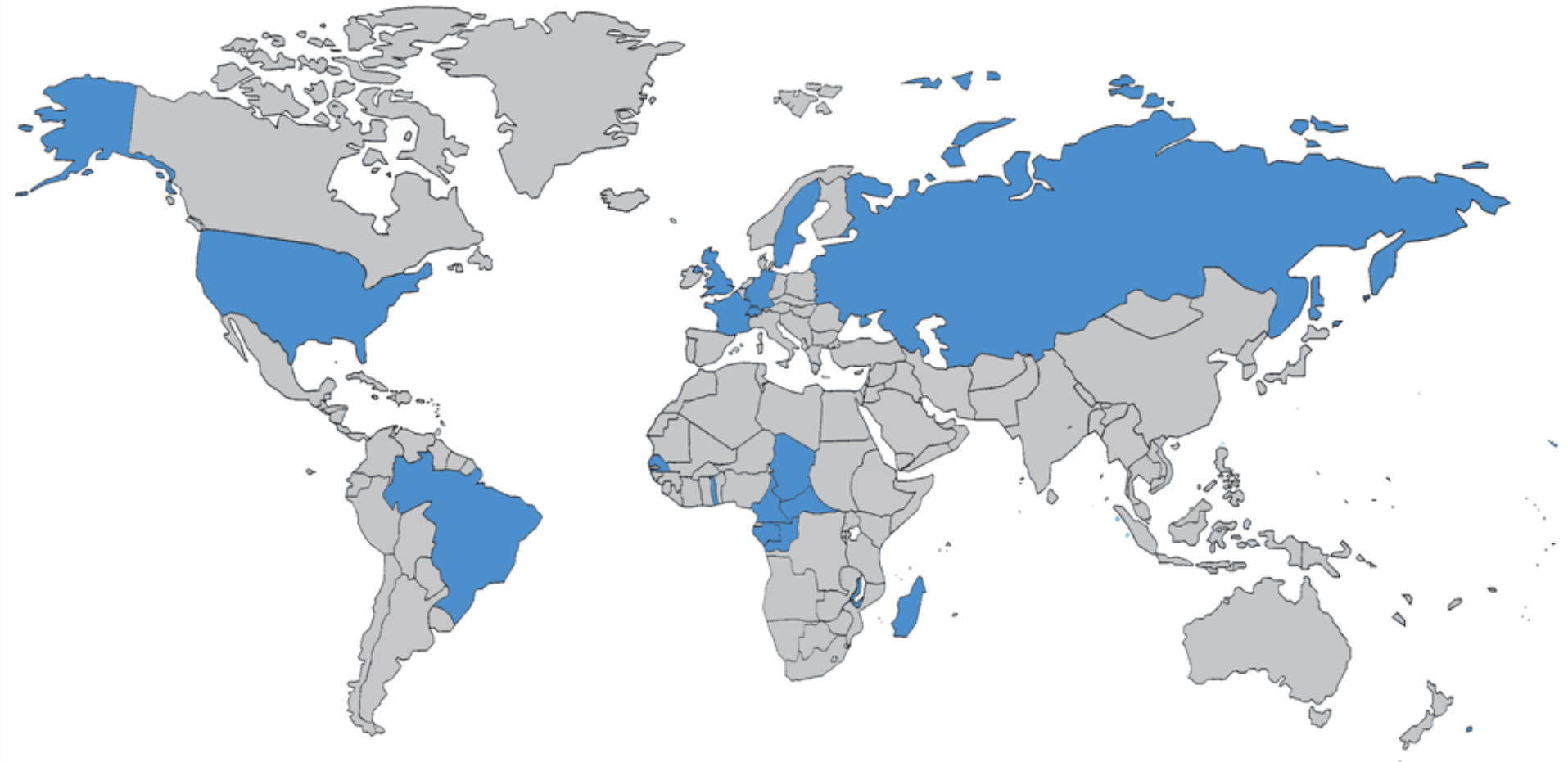

# PCT Coverage Today

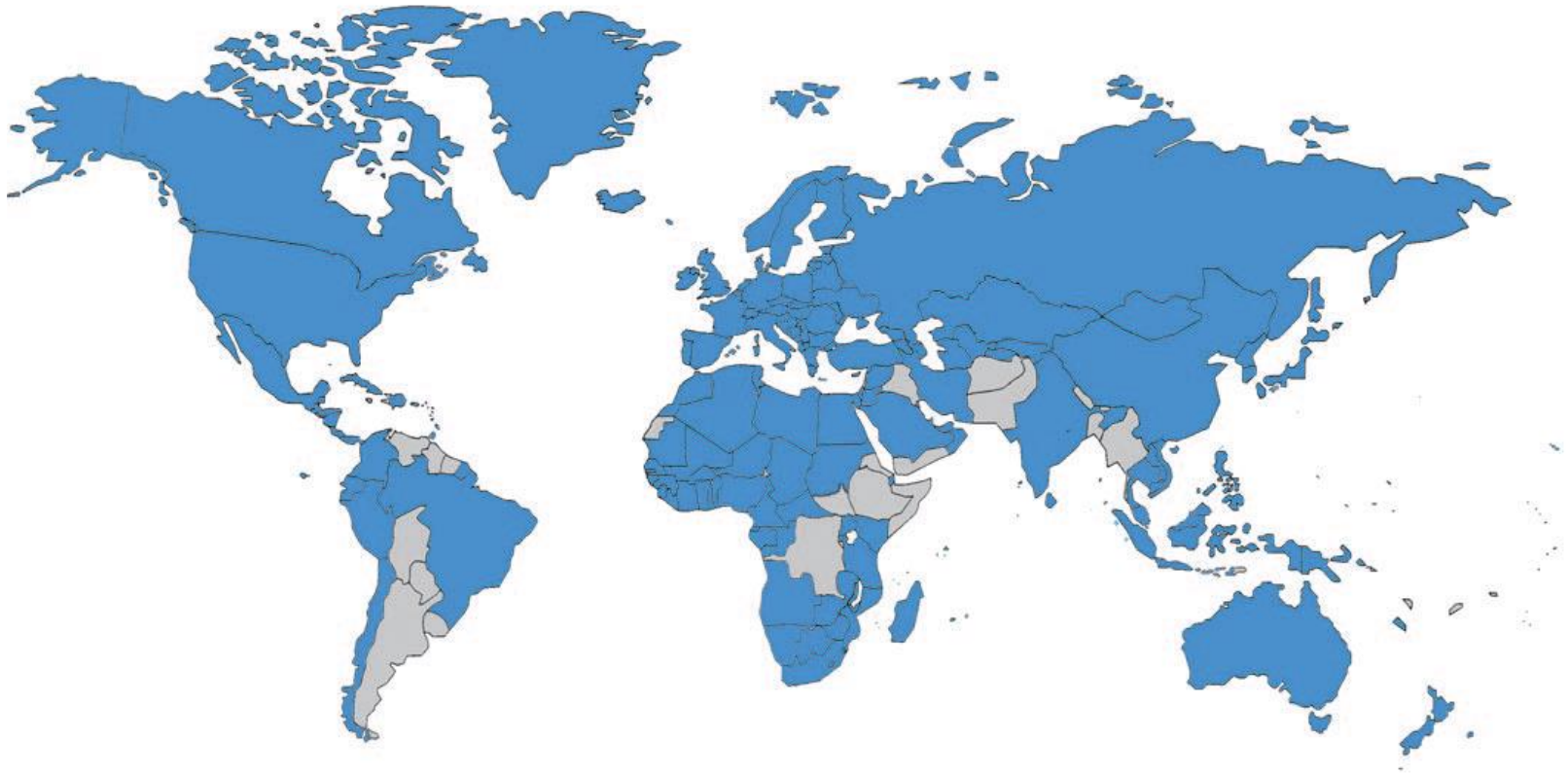

**152 PCT Contracting States**

# Countries not yet PCT Contracting States (41)

Afghanistan

Andorra

Argentina

Bahamas

Bangladesh

Bhutan

Bolivia

Burundi

Cabo Verde

Democratic Republic of

Congo

Eritrea

Ethiopia

Fiji

Guyana

Haiti

Iraq

Jamaica

Kiribati

Lebanon

Maldives

Marshall Islands

Mauritius

Micronesia

Myanmar

Nauru

Nepal

Pakistan

Palau

Paraguay

Samoa

Solomon Islands

Somalia

South Sudan

Suriname

Timor-Leste

Tonga

Tuvalu

Uruguay

Vanuatu

Venezuela

Yemen



**WIPO**

WORLD  
INTELLECTUAL PROPERTY  
ORGANIZATION



# Statistics

# PCT Applications (2017)

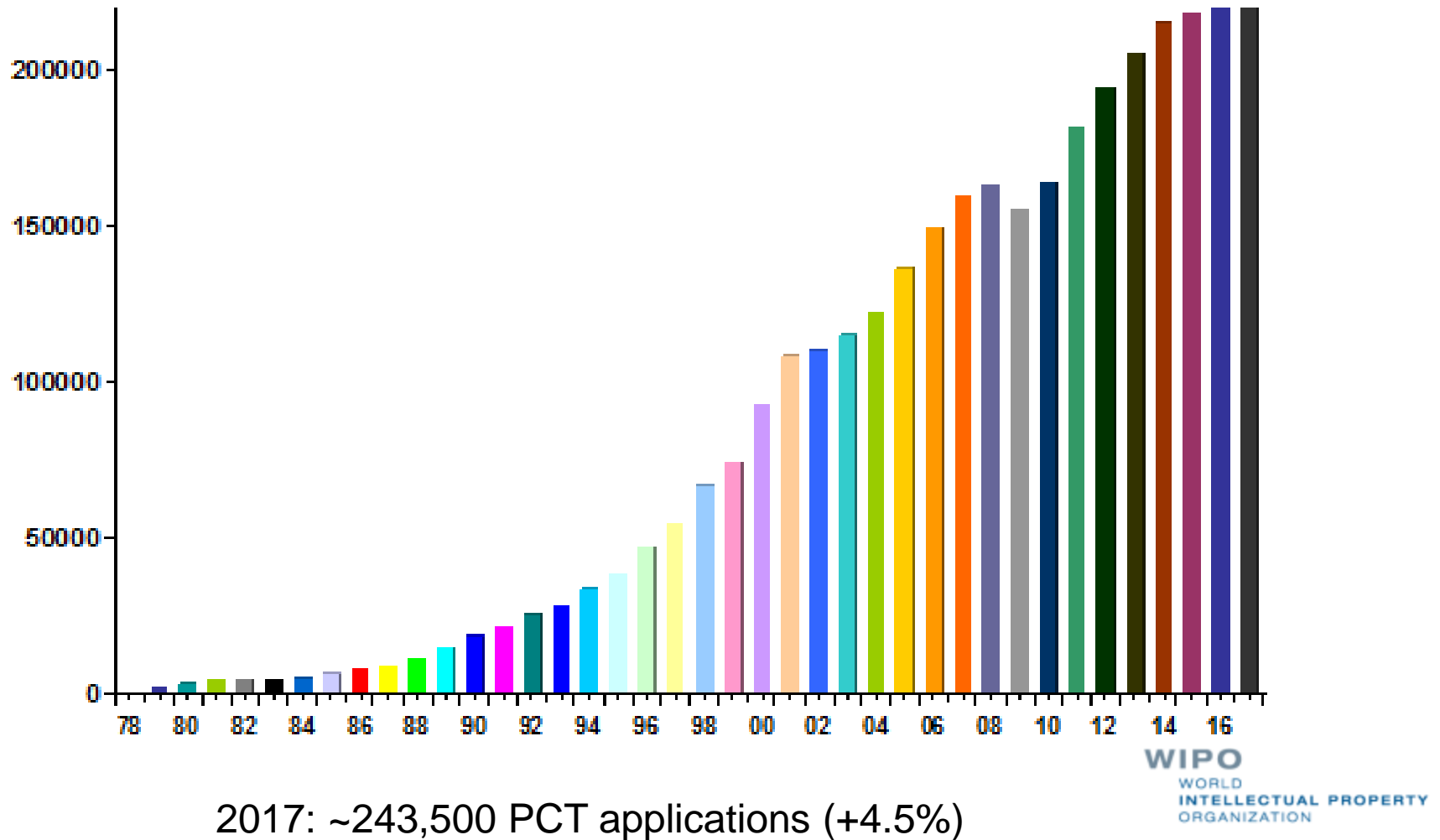

# International Applications received by Country of Origin (2017)

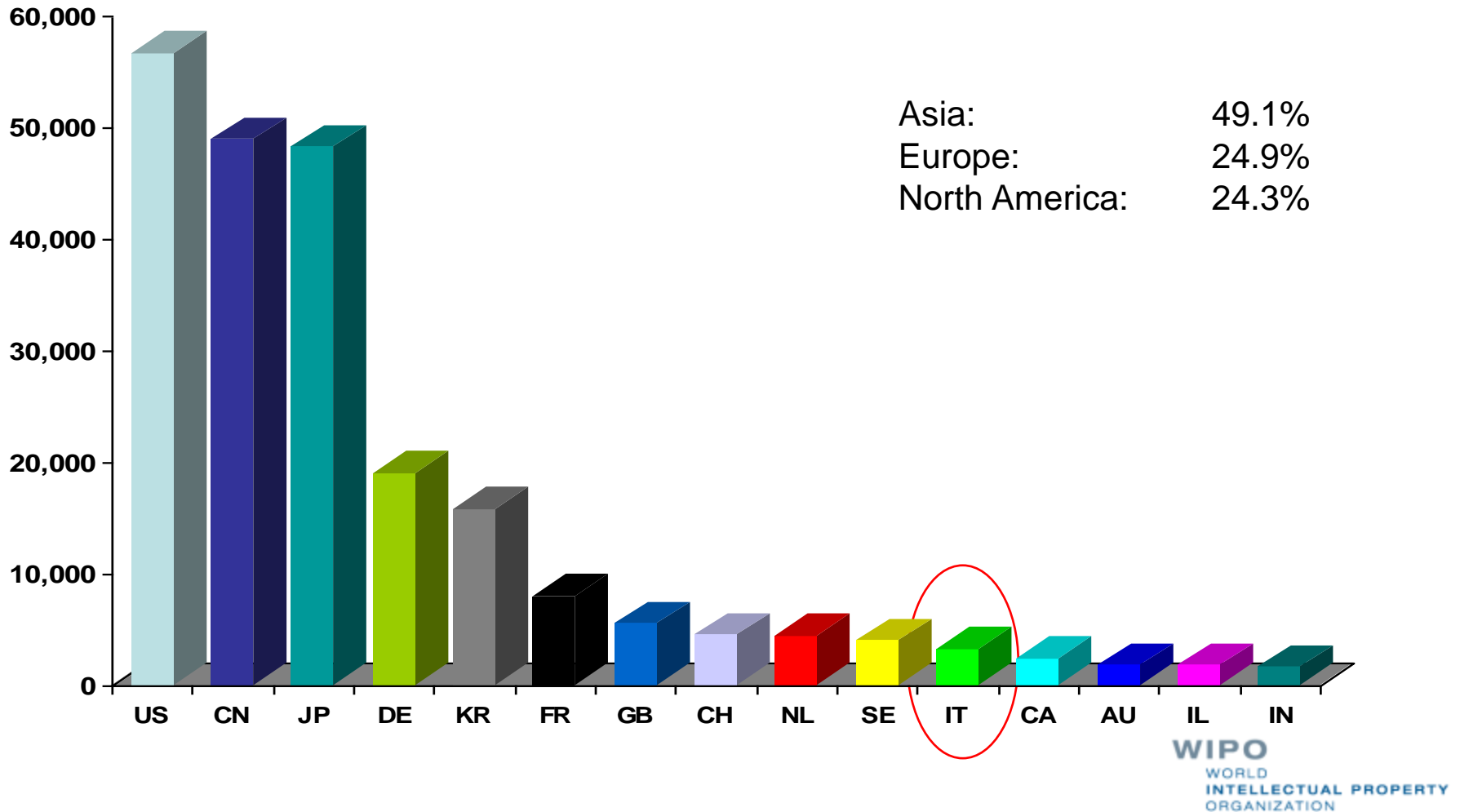

# Top 10 PCT Applicants (2017)

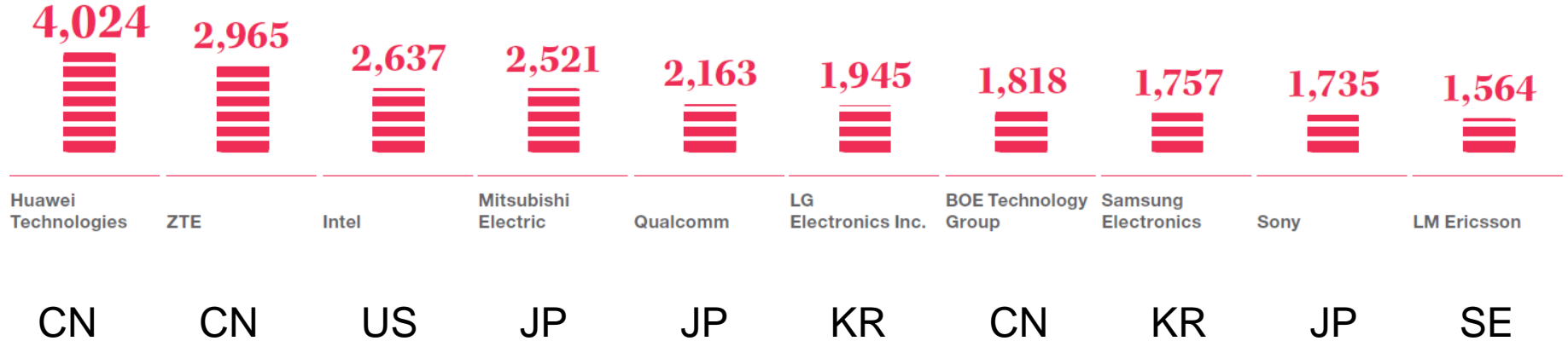

# Top 5 Fields of Technology

19,122

COMPUTER  
TECHNOLOGY

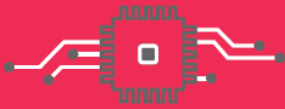

8.6%

18,400

DIGITAL  
COMMUNICATION



8.2%

15,223

ELECTRICAL  
MACHINERY,  
APPARATUS, ENERGY



6.8%

15,024

MEDICAL  
TECHNOLOGY



6.7%

10,082

MEASUREMENT

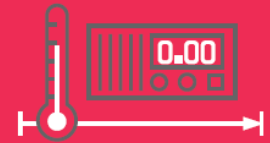

4.5%



# Top PCT Applicants from Italy in 2016

<b>Applicant</b>	<b>Publication</b>	<b>Rank</b>
NUOVO PIGNONE SRL	57	387
G.D SOCIETA' PER AZIONI	46	482
SOLVAY SPECIALTY POLYMERS ITALY S.P.A.	36	608
PIRELLI TYRE S.P.A.	32	689
PRYSMIAN CAVI E SISTEMI ENERGIA S.R.L.	29	755
ENI S.P.A.	28	781
TELECOM ITALIA S.P.A.	26	841
BASELL POLIOLEFINE ITALIA S.R.L.	20	1109
PIAGGIO & C. S.P.A.	19	1165
SAIPEM S.P.A.	18	1205

# Patent Applications by Top Fields of Technology - Italy (2007 - 2016)

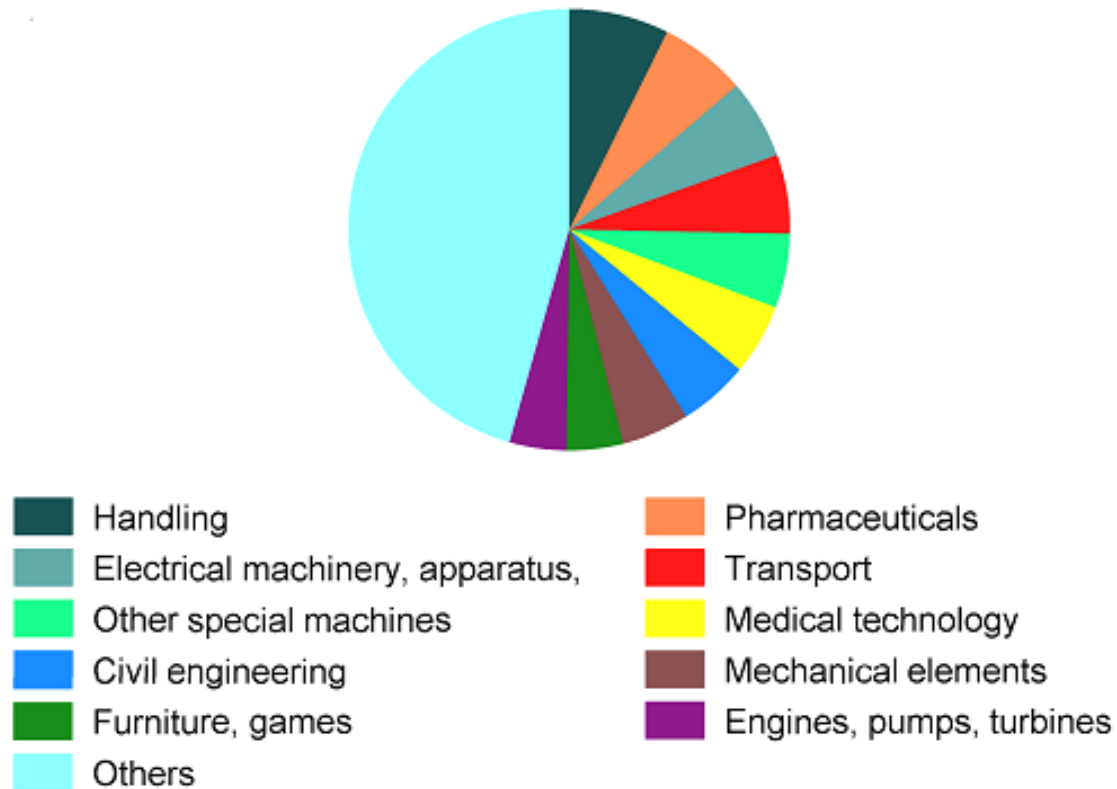

Source: WIPO statistics database; last updated: 3/2018



# Information and Training

# Training Options

- PCT-Geneva seminar every September/October
- On-site seminars in various locations around the world
- Distance Learning Course
  - Basic course available in all 10 publication languages
  - Advanced course coming soon
- Webinars
  - Regular updates on latest developments in the PCT system in all 10 PCT publication languages
  - Topic-specific (e.g. ePCT)
- YouTube Videos (“Learn the PCT”)
  - 29 short videos about individual topics
- Customized training on request

# Where To Get Help

- For further information about the PCT
  - PCT Website at <http://www.wipo.int/pct/en/>
  - PCT Yearly Review at:  
<http://www.wipo.int/pct/en/activity/>
  
- PCT Information Service
  - Telephone: (+41-22) 338 83 38
  - E-mail: [pct.infoline@wipo.int](mailto:pct.infoline@wipo.int)



# **The Madrid System**

## **International Registration of Trademarks**

# **The Hague System**

## **International Registration of Industrial Designs**



Ms. Alexandra Grazioli, Director, Lisbon Registry, Law and Legislative Advice Division, Brands and Designs Sector, WIPO

**Brescia, Italy, April 10, 2018**



# **The Madrid System for the International Registration of Marks**

# General Overview of the Madrid System



Basic features and advantages



Going global – geographical scope



How the System works



Some statistics



Latest developments and  
upcoming features



# Trademarks

## ■ What can be protected?



# It begins with a trademark and a plan to export...



**GENERALI**  
Assicurazioni Generali S.p.A.

# VALLEVERDE

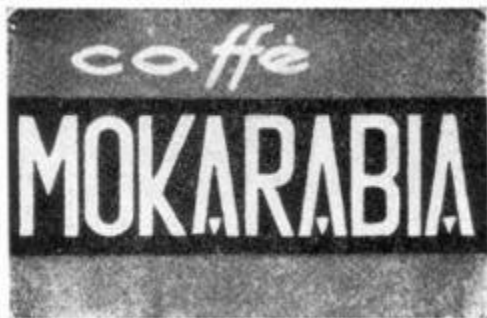

**WIPO**  
WORLD  
INTELLECTUAL PROPERTY  
ORGANIZATION

# Protection Options

...Then a choice must be made regarding the best way to protect your trademark/s abroad:

- **The national route:** file trademark application/s with the IP Office of each country in which you want protection
- **The regional route:** apply through a regional trademark registration system with effect in all member states (ARIPO, Benelux Office for IP, EUIPO and OAPI)
- **The international route:** file through the Madrid System

# The International Route

The international route through the Madrid System may be the preferred option when you:

- Seek protection in **multiple markets**, particularly if these are in different regions
- Want **flexibility to add new markets** as your export plans develop
- Have **limited budget and/or time** to spend on registration and management of your trademarks

# The Madrid System is Convenient

- Access a **centralized filing and management** procedure
- File one application, in **one language** and pay **one set of fees** for protection in multiple markets
- **Expand protection** to new markets as your business strategy evolves

# The Madrid System is Cost-Effective

- File an international application, which is the equivalent of a bundle of national applications, **effectively saving time and money**
- **Avoid** paying for **translations** into multiple languages or working through the administrative procedures of **multiple IP Offices**

# The Madrid System is Global

- Currently: **116 countries** covered by the **100 members**
- Markets that represent more than **80% of world trade**
- Recent accessions include:
  - **2014: OAPI and Zimbabwe**
  - **2015: Algeria, Cambodia, The Gambia and Lao People's Democratic Republic**
  - **2016: Brunei Darussalam**
  - **2017: Thailand, Indonesia**

# Members of the Madrid System

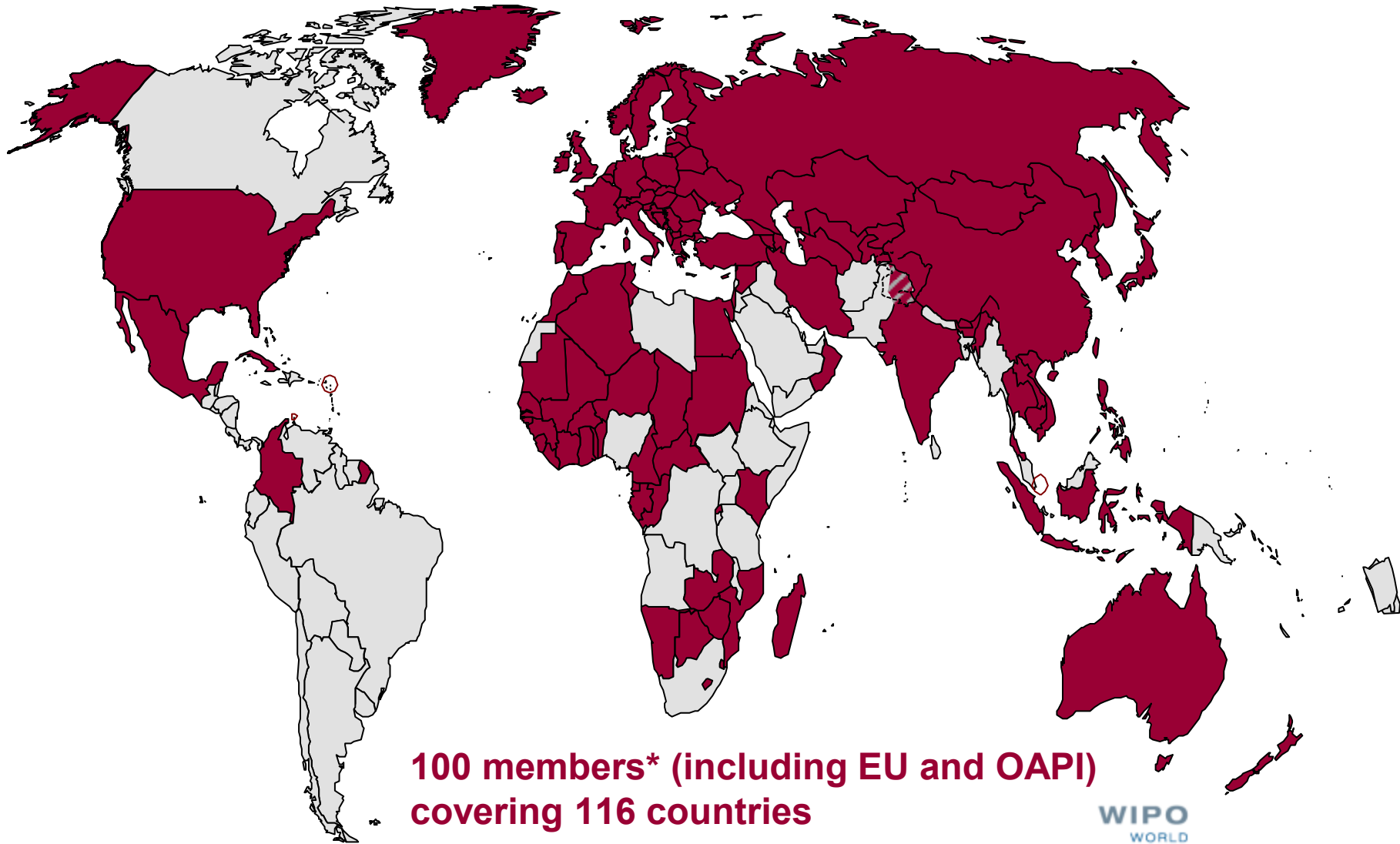

**100 members\* (including EU and OAPI)  
covering 116 countries**

**WIPO**  
WORLD  
INTELLECTUAL PROPERTY  
ORGANIZATION

\*All are party to the Protocol, the governing treaty, while 55 are also party to the Agreement



# Accession Outlook 2018/19

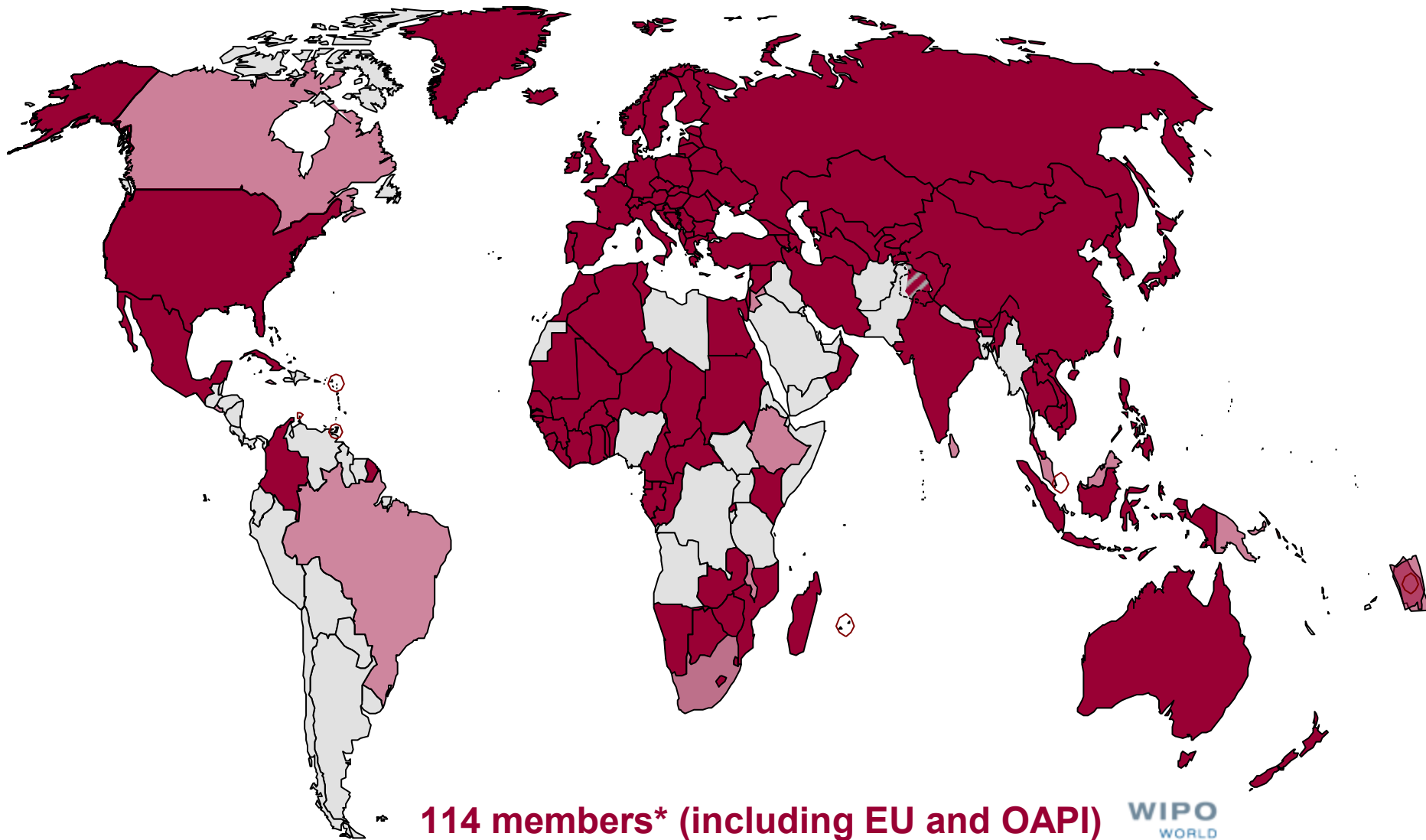

**114 members\* (including EU and OAPI)  
covering 130 countries**

# Accession Outlook – 2017/19

- **Africa:** Ethiopia, Malawi, Mauritius, South Africa
- **Arab region:** Jordan, Saudi Arabia
- **Asia:** Malaysia, Papua New Guinea, Samoa, Sri Lanka
- **Europe:** Malta
- **Latin America and the Caribbean:** Barbados, Brazil, Costa Rica, El Salvador, Jamaica, Trinidad and Tobago
- **North America:** Canada

# Legal Framework

- Madrid Agreement (1891)
- Madrid Protocol (1989)
- Common Regulations
- Administrative Instructions
  
- Laws and Regulations of each Contracting Party

See: [http://www.wipo.int/madrid/en/legal\\_texts/](http://www.wipo.int/madrid/en/legal_texts/)  
<http://www.wipo.int/madrid/memberprofiles/#/>

# Madrid System Users: Business Sectors

- Madrid System users come from **all corners of the globe** and represent a **broad cross-section of industries**



# Top Five Classes

13,646

COMPUTERS AND  
ELECTRONICS



9.8%

11,079

SERVICES FOR  
BUSINESS



7.9%

8,607

TECHNOLOGICAL  
SERVICES



6.2%

6,587

LEISURE, EDUCATION  
AND TRAINING  
SERVICES



4.7%

6,239

PHARMACEUTICALS



4.5%

# Madrid System Users: Business Size

- Individual entrepreneurs, small and large businesses find the Madrid System to be a convenient and cost-effective means to protect marks in key markets throughout the world

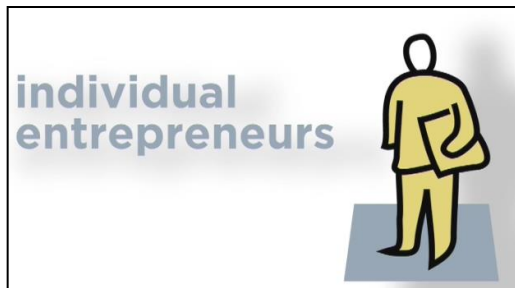

# Top Applicants

#	Name	Origin	Applications
1	L'ORÉAL	France	198
2	RICHTER GEDEON NYRT.	Hungary	117
3	ADP GAUSELMANN GMBH	Germany	104
4	NOVARTIS AG	Switzerland	96
5	ABERCROMBIE & FITCH EUROPE SA	Switzerland	82
6	APPLE INC.	US	74
7	BRILLUX GMBH & CO. KG	Germany	73
7	KRKA, TOVARNA ZDRAVIL, D.D., NOVO MESTO	Slovenia	73
8	BAYERISCHE MOTOREN WERKE AKTIENGESELLSCHAFT	Germany	70
9	AUCMA COMPANY LIMITED	China	62
9	JANSSEN PHARMACEUTICA N.V.	Belgium	62

# More than 1.3 Million International Registrations



- This **LONGINES** mark is the oldest trademark still in effect
- Registered in Switzerland in 1889, internationally in **1893**



- **SKINSTUDIO** is international trademark registration 1.3 million
- Registered in Singapore in 2015, internationally in **2016**



# How the Madrid System Works

## The International Trademark Registration Process



# Costs

**Fees are payable to WIPO in Swiss francs**

■ **Basic fee\*:**

- 653 Swiss francs – b/w reproduction of mark
- 903 Swiss francs – color reproduction of mark

■ **Fees for designated Contracting Parties (dCP)**

■ **Standard fees:**

- complementary (100 Swiss francs per dCP) and
- supplementary (100 Swiss francs  
per class beyond 3)

**OR**

■ **Individual fees** where this is declared

# Timeline

## The International Trademark Registration Process

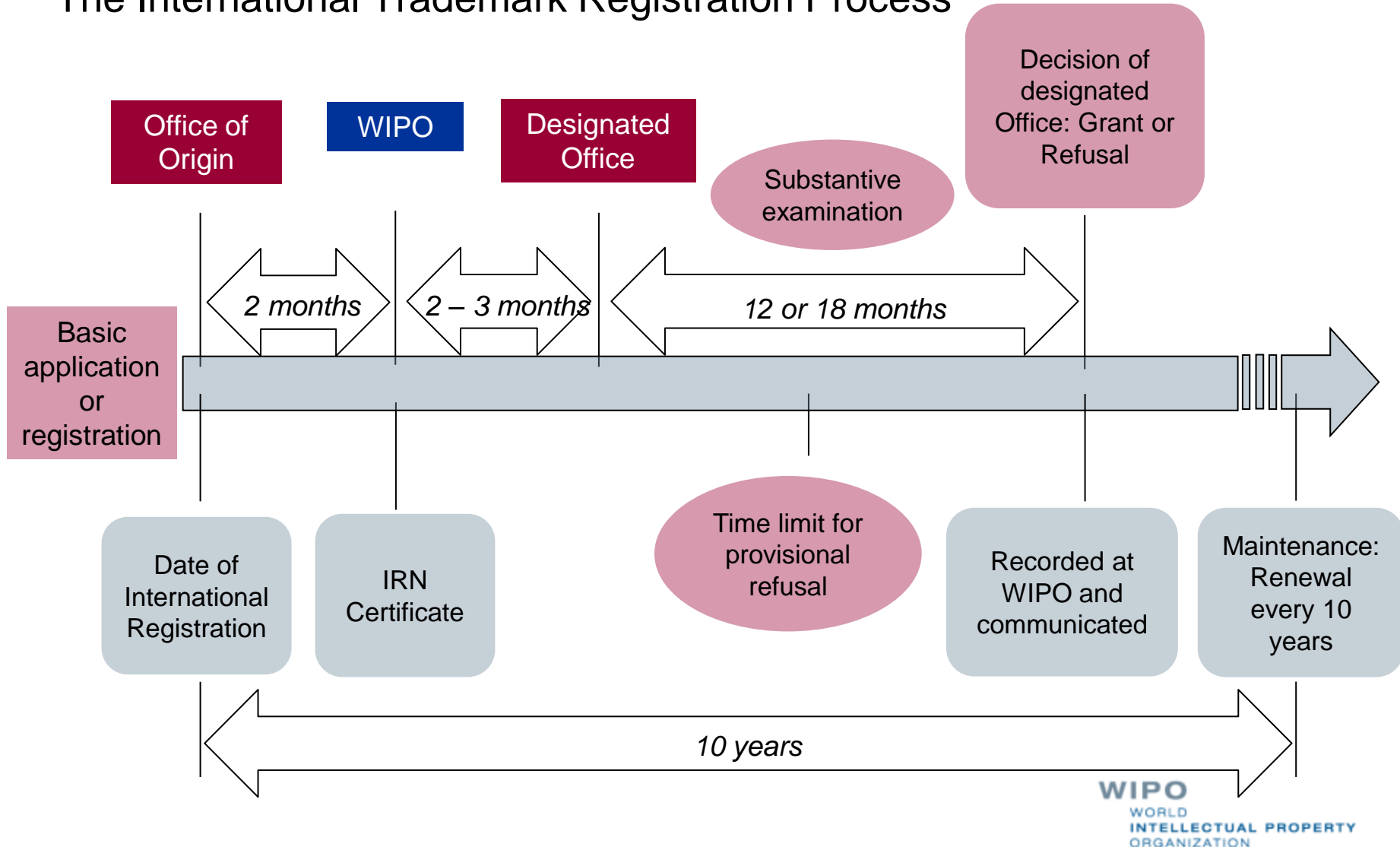

# Website and E-Services

- The Madrid Website provides information on how to search before filing, file an application, monitor and manage registrations, and how to pay fees.
- Madrid E-Services are available to assist users at each stage of their mark's lifecycle.



# E-Services

**Search**



**File**



**Monitor**



**Manage**



## Global Brand Database

- search existing marks from national & international sources
- trademarks, appellations of origin and official emblems

## Madrid Goods & Services Manager

- compile a list of approved goods & services terms in 18 languages

## Member Profiles Database

## Fee Calculator

## Madrid Monitor

- track real-time status of registration
- watch competitors' marks
- e-alerts
- consult the WIPO Gazette

## Madrid Portfolio Manager

- access documents
- request changes
- modify, designate & renew
- pay fees
- obtain extracts

# International Applications

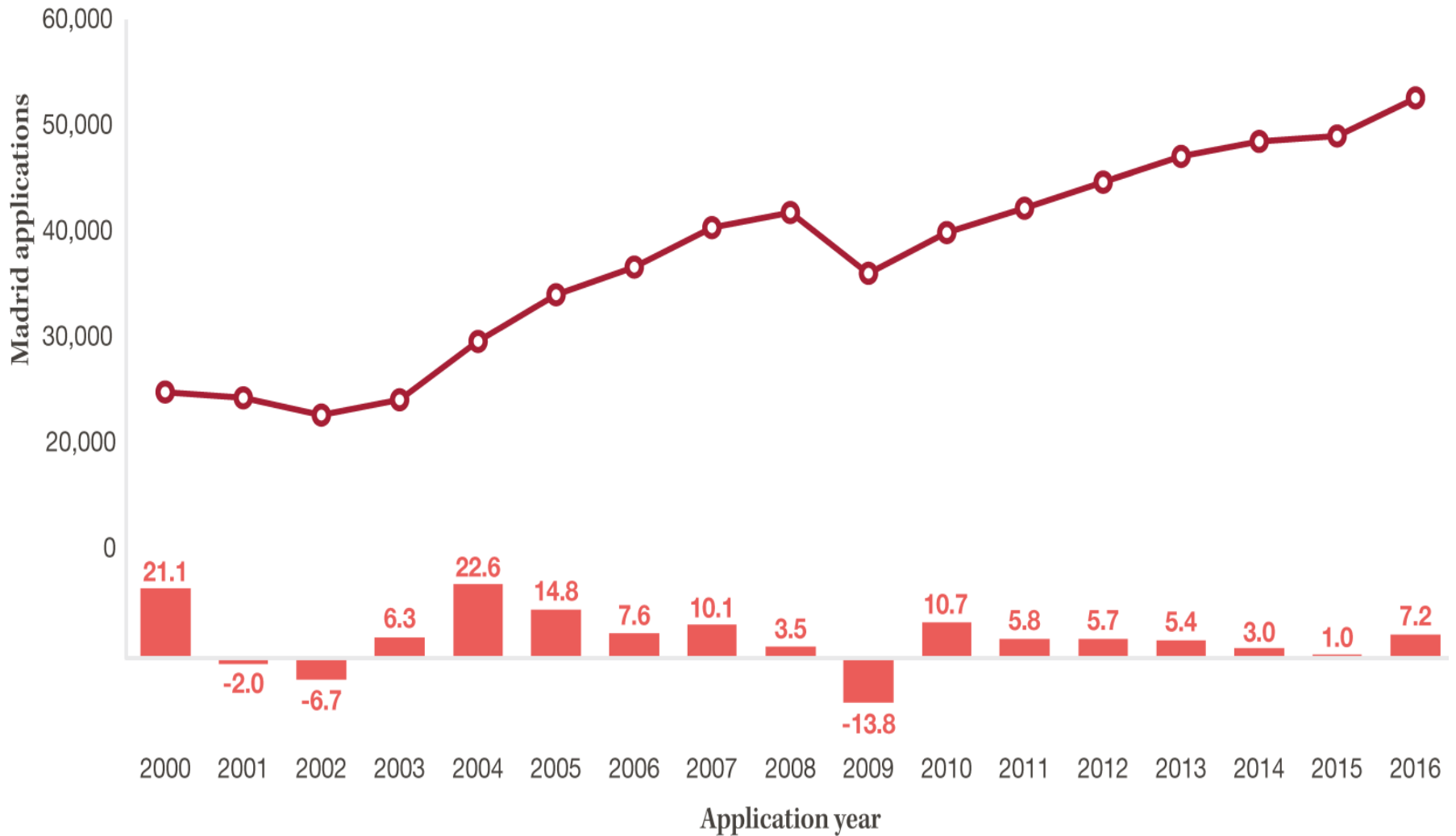

■ MADRID APPLICATIONS

■ GROWTH RATE (%)

# Key Figures (2017)

Description	Number	Growth
International applications	52,550	+7.2%
International registrations (IRs)	44,726	-13.9%
Designations in international applications	353,268	+6.2%
Subsequent designations in IRs	45,633	-5.7%
Renewals of IRs	29,546	+2%
<b>Active IRs</b>	<b>641,587</b>	<b>+2.5%</b>
Active designations in IRs	5,688,043	+0.4%
Overall Madrid share ( <i>non-resident trademark filing, Madrid members only</i> )	63%	-2% point
Contracting Parties (Madrid members)	100	+2
Countries covered	116	+2

# General Profile 2016

## 44,726 International Registrations

Average Number of Designations	6.7
Average Number of Classes	2.47
Average Fee	CHF 2,968
All Fees	70% < CHF 3,000



# Top Ten Filing Origins

## TOP 10 COUNTRIES

Number of Madrid applications and % growth since 2016

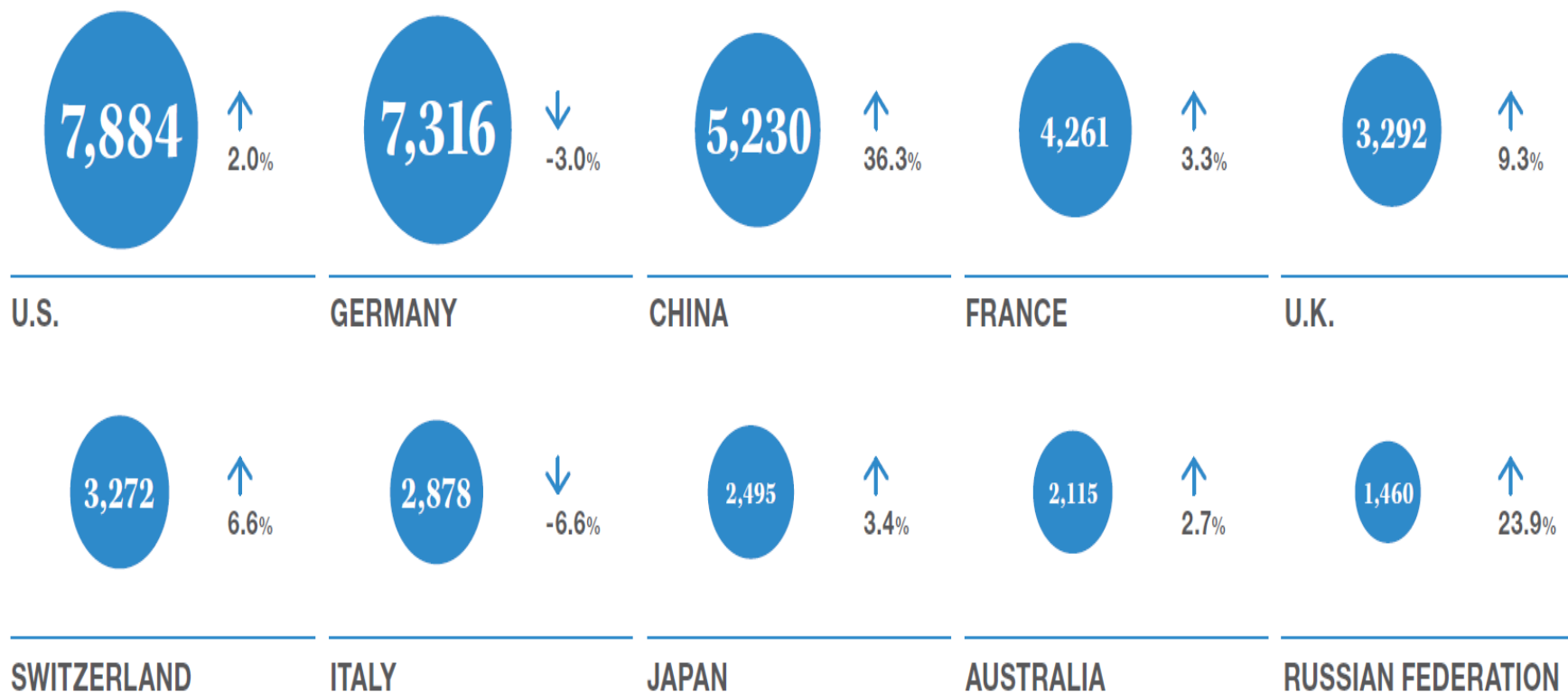

**2016: Italy #6 with a 5.7% growth**  
**2017: Italy #7 with a 6,6% decrease**

# Top 10 Designated Contracting Parties (2017)

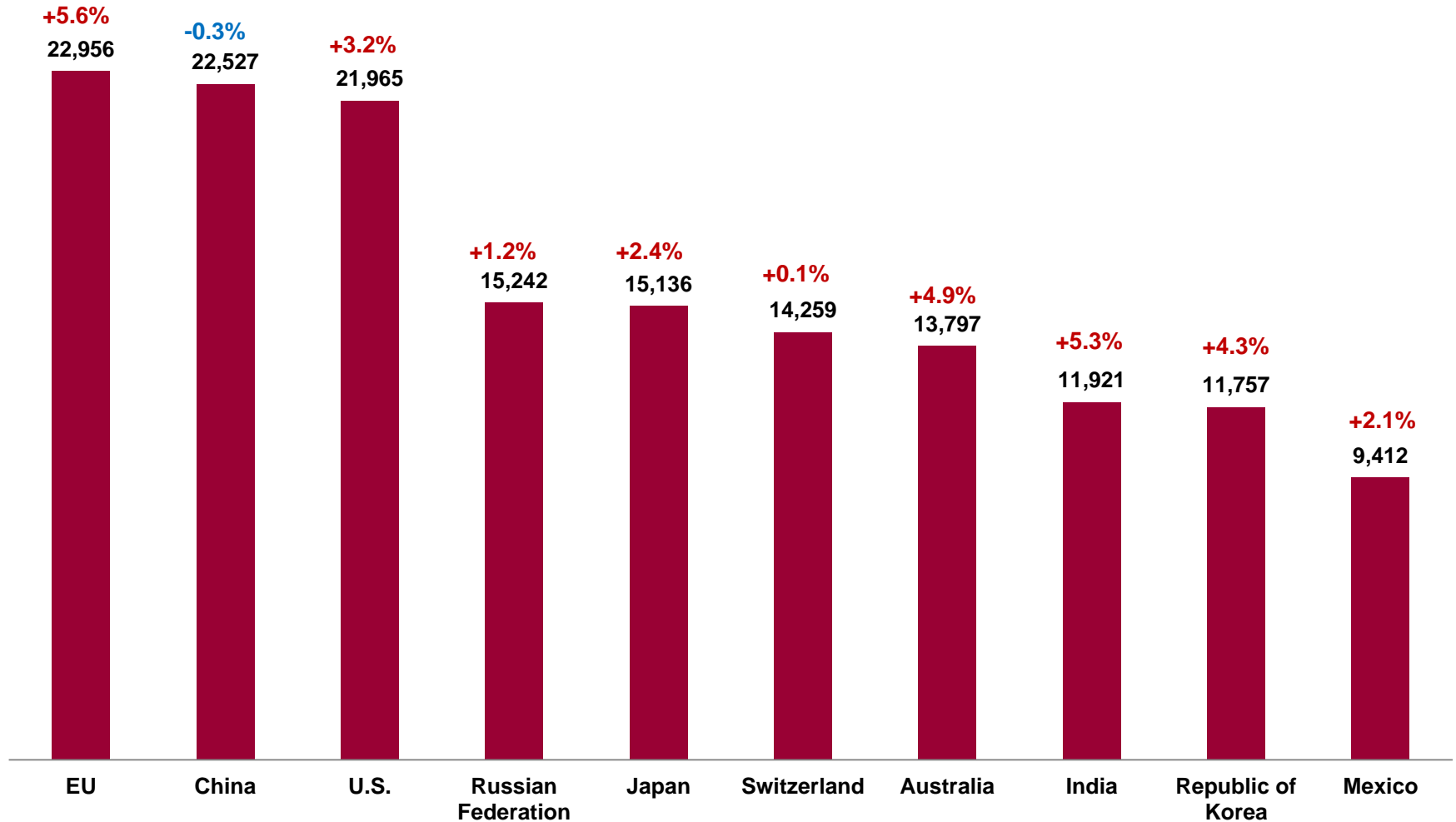

# International Applications and Registrations: Italy

## International Applications and Registrations by Office of Origin: Italy

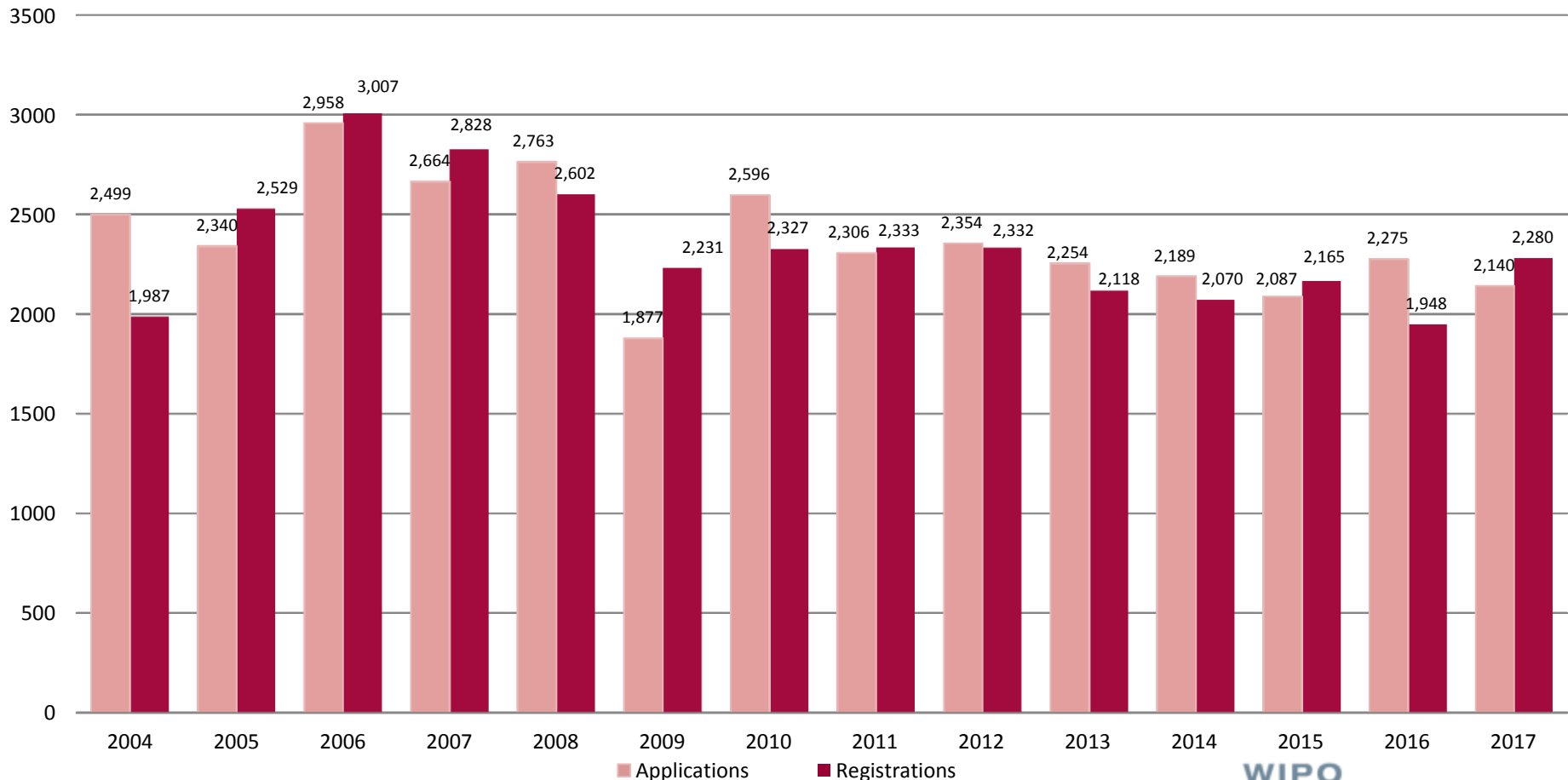

# Top Designated Contracting Parties: Italian Holders

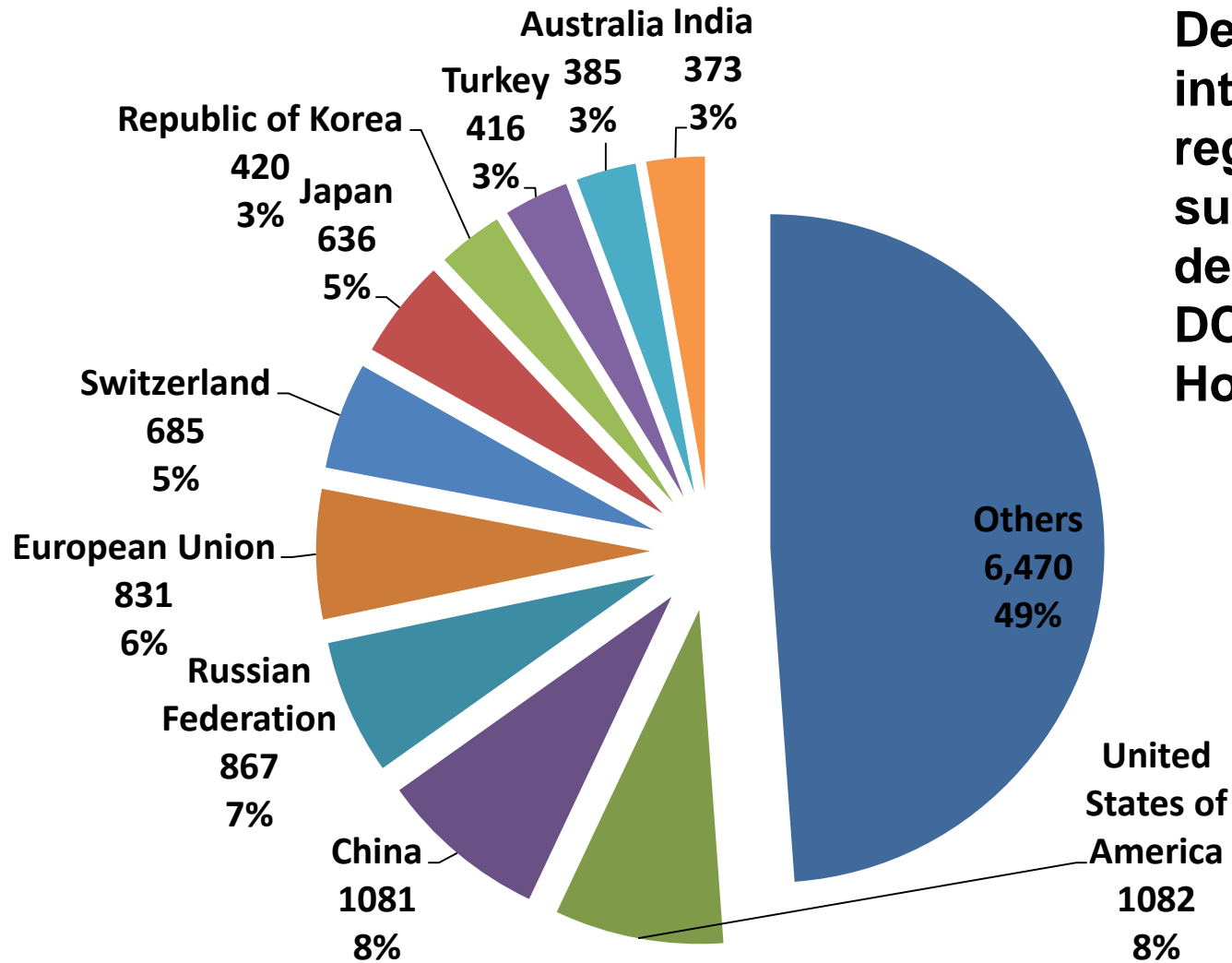

Designations in international registrations & subsequent designations by DCPs, Country of Holder: Italy (2016)

# Designations of Italy by Country of Holder

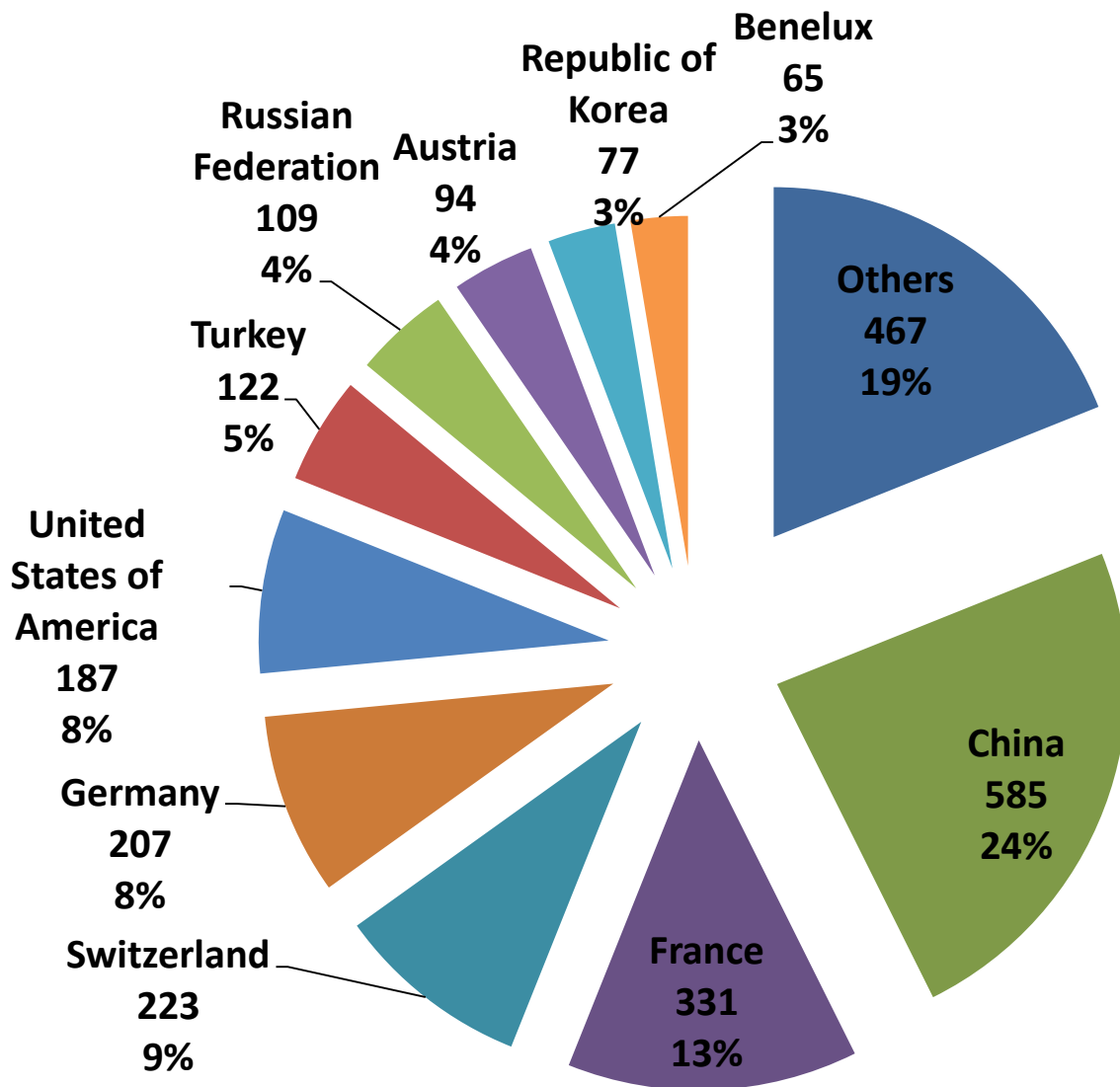

**Designations of Italy in international registrations & subsequent designations by Country of Holder (2016)**

# Top Applicants 2016 (Italy)

Applicant	2016 # Applications
<b>BULGARI S.P.A</b> 	19
<b>ISKO S.R.L.</b> 	18
<b>SOCIETA AGRICOLA CIU CIU DI BARTOLOMEI MASSIMILIANO E BARTOLOMEI WALTER S.S.</b> 	16
<b>FIDIA FARMACEUTICI S.P.A.</b> 	14
<b>IVECO S.P.A.</b> 	13

# Recent Developments

- Rules Changes in the Common Regulations
- Classification Guidelines
- WIPO Current Account
- Madrid Monitor: it integrates ROMARIN, the WIPO Gazette, Madrid E-Alert and Real-time Status
- Member Profiles Database
- New Contact Madrid service (online form)  
*November 1, 2017*

# Rule changes (2017 & 2019)

- **Changes to the Common Regulations adopted by the Madrid Union Assembly (after recommendation by the Working Group for the Legal development of the Madrid System)**
- **Entry into force of the most recent changes;**
  - July 1, 2017
  - November 1, 2017
  - February 1, 2019



# Classification Guidelines

- **Purpose – to decrease irregularities**
- **Describes WIPO classification practices**
- **Divided into three sections:**
  - General information – Nice Classification and Madrid
  - Classification principles applied by WIPO
  - Practical information on the acceptable format to list indications of goods and services



# WIPO Current Account Changes

- **No minimum number of transactions**
- **Initial payment of CHF 2,000**
- **Minimum balance: notification sent to users if balance is less than CHF 200**
- **A form to open the account available on the website**
- **Email address required**
- **Account statement sent by email only**

# NEW – Contact Madrid



**Single point of  
contact**



**Standardized  
input data**

*Mandatory fields  
Input fields allow  
better  
understanding of  
needs*



**Quick &  
automated  
distribution to  
relevant team**

*Speedy processing  
of requests*

# Contact Madrid: from Nov. 2017



intreg.mail@wipo.int



WIPO contact us



madrid.team1@wipo.int



madrid.team2@wipo.int



madrid.team3@wipo.int



madrid.records@wipo.int



WIPO fax

Closed Nov 2017

Closed Dec 2017

Closed April 1, 2018

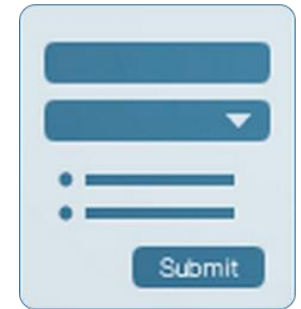

Contact Madrid

# Where to Access Contact Madrid

■ <http://www.wipo.int/madrid/en/#contact>

The screenshot shows the top navigation bar of the WIPO website with links for Media, Meetings, Contact Us, My Account, and English. Below this is the WIPO logo and the text 'WORLD INTELLECTUAL PROPERTY ORGANIZATION'. A secondary navigation bar includes links for IP Services, Policy, Cooperation, Knowledge, About IP, and About WIPO, along with a search bar labeled 'Search WIPO'. A breadcrumb trail at the bottom of the navigation bar reads 'Home > IP Services > Madrid System' and a 'On this page' dropdown menu is visible on the right.

**WIPO**  
WORLD INTELLECTUAL PROPERTY ORGANIZATION

Media | Meetings | Contact Us | My Account | English ▾

IP Services | Policy | Cooperation | Knowledge | About IP | About WIPO | Search WIPO 🔍

Home > IP Services > Madrid System | On this page ▾

## Contacts

Madrid Customer Service opening hours: Monday - Friday, 9:00 a.m. to 6:00 p.m. (Geneva time).

<b>Enquiries / submitting forms</b>	<b>Extracts from the International Register</b>
<ul style="list-style-type: none"><li>• <a href="#">Contact Madrid</a></li><li>• Tel: +41 22 338 86 86</li></ul>	<ul style="list-style-type: none"><li>• <a href="#">Contact Madrid</a></li><li>• Tel: +41 22 338 8484</li></ul>

# Keep Updated on the Madrid System

- Visit the Madrid Website

[www.wipo.int/madrid/en](http://www.wipo.int/madrid/en)

- Register to free

[Madrid Webinars](#)

- Subscribe to [Madrid Notices](#), our legal and news updates

- Sign up for [Madrid Highlights](#)





# **The Hague System for the International Registration of Industrial Designs**

# General Overview of the Hague System



Basic features and advantages



How the Hague System works



Going global – geographical scope



Some statistics



Latest developments and  
upcoming features



# Industrial Designs

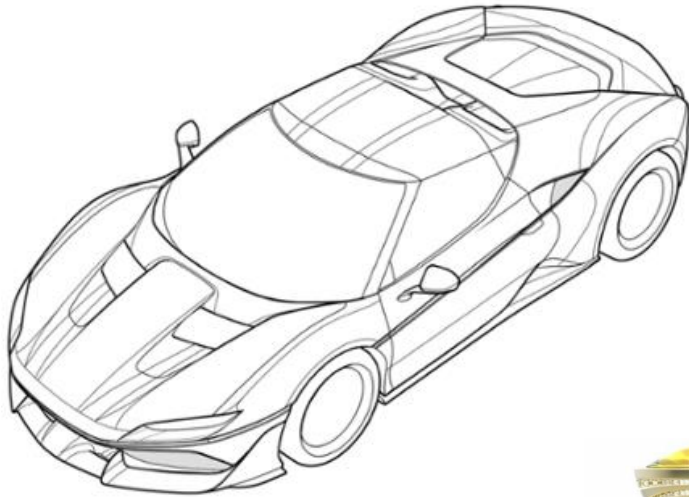

DM/097114



DM/090520



DM/083330

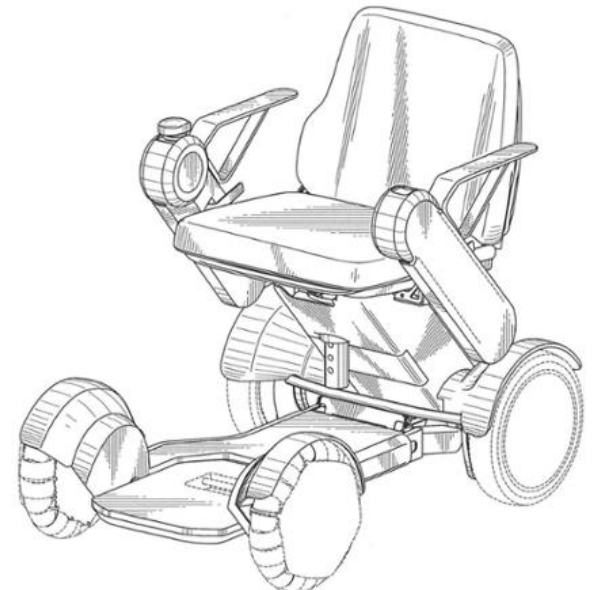

DM/097600  
INTELLECTUAL PROPERTY  
REGISTRATION

# Why Protect Industrial Designs?

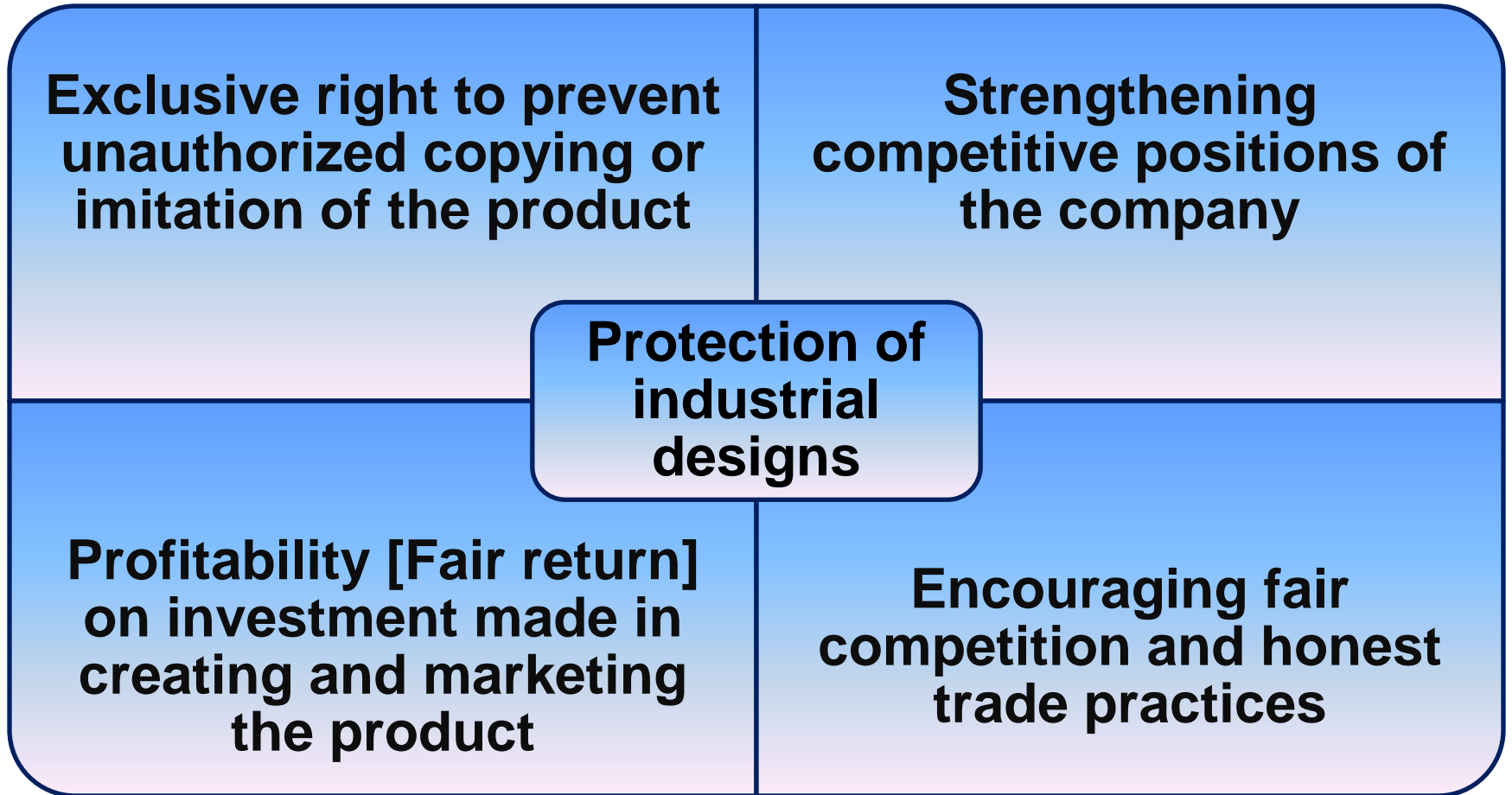

# Hague System: A Simple But Timeless Concept

The **centralized** acquisition and maintenance of industrial design rights by **filing a single international application** for a single international registration **with effect in one or more designated Contracting Parties**



# Independent filings vs. Hague Route

## Direct/Paris Route

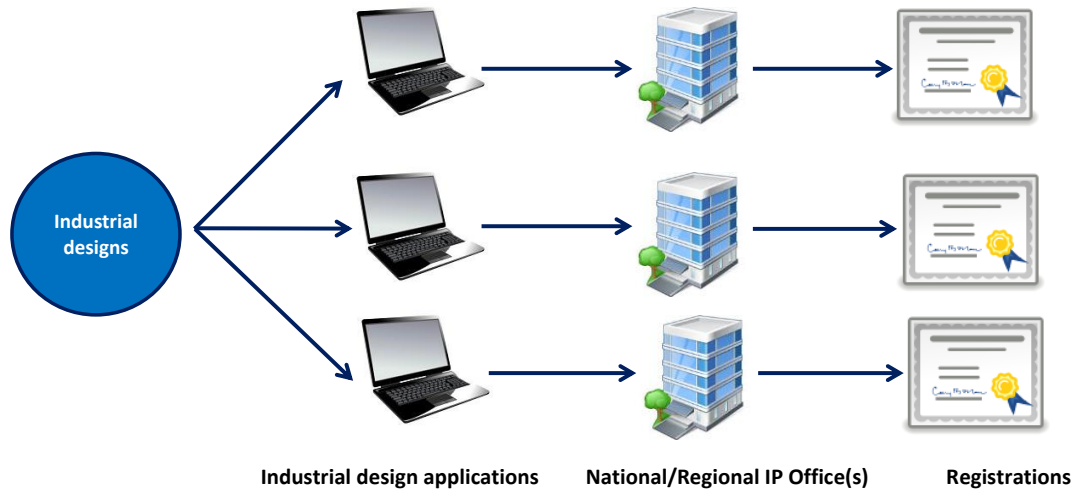

## The Hague System

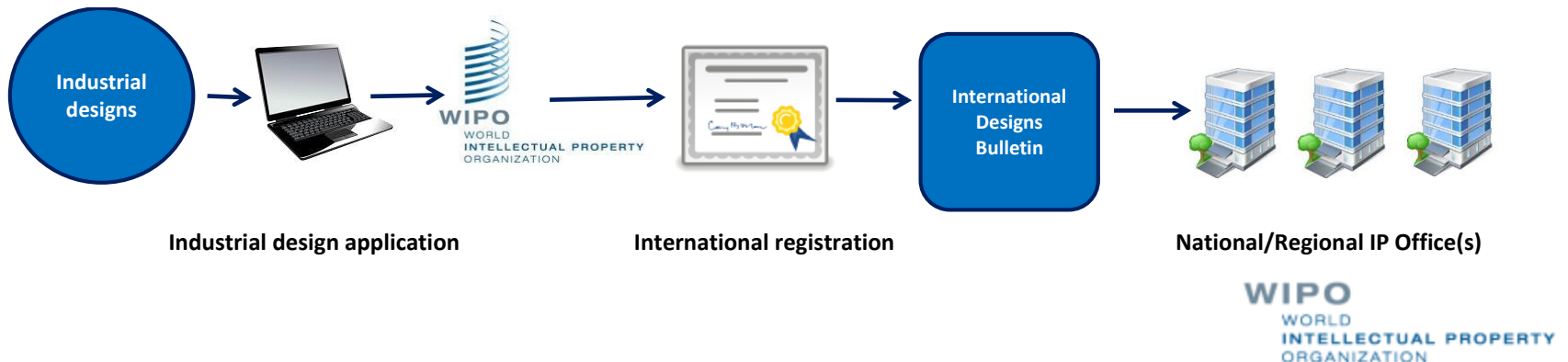

# Main Features of the Hague System



## Simplicity

The Hague System enables holders to obtain protection for their designs with a minimum of formality



## Cost-effectiveness

Payment of a single set of fees in one currency



## Efficiency

Considerable facilitation of the subsequent management of the registration



## Flexibility

Right holders have more opportunities in targeting national, regional or global markets

# The Hague System is a Procedural Arrangement

Issues such as:



the conditions for protection



the refusal procedure to be applied when  
deciding whether a design may be protected



the rights which result from protection

are governed by the law of each Contracting Party  
designated in an international registration

# Who Can Use the System?

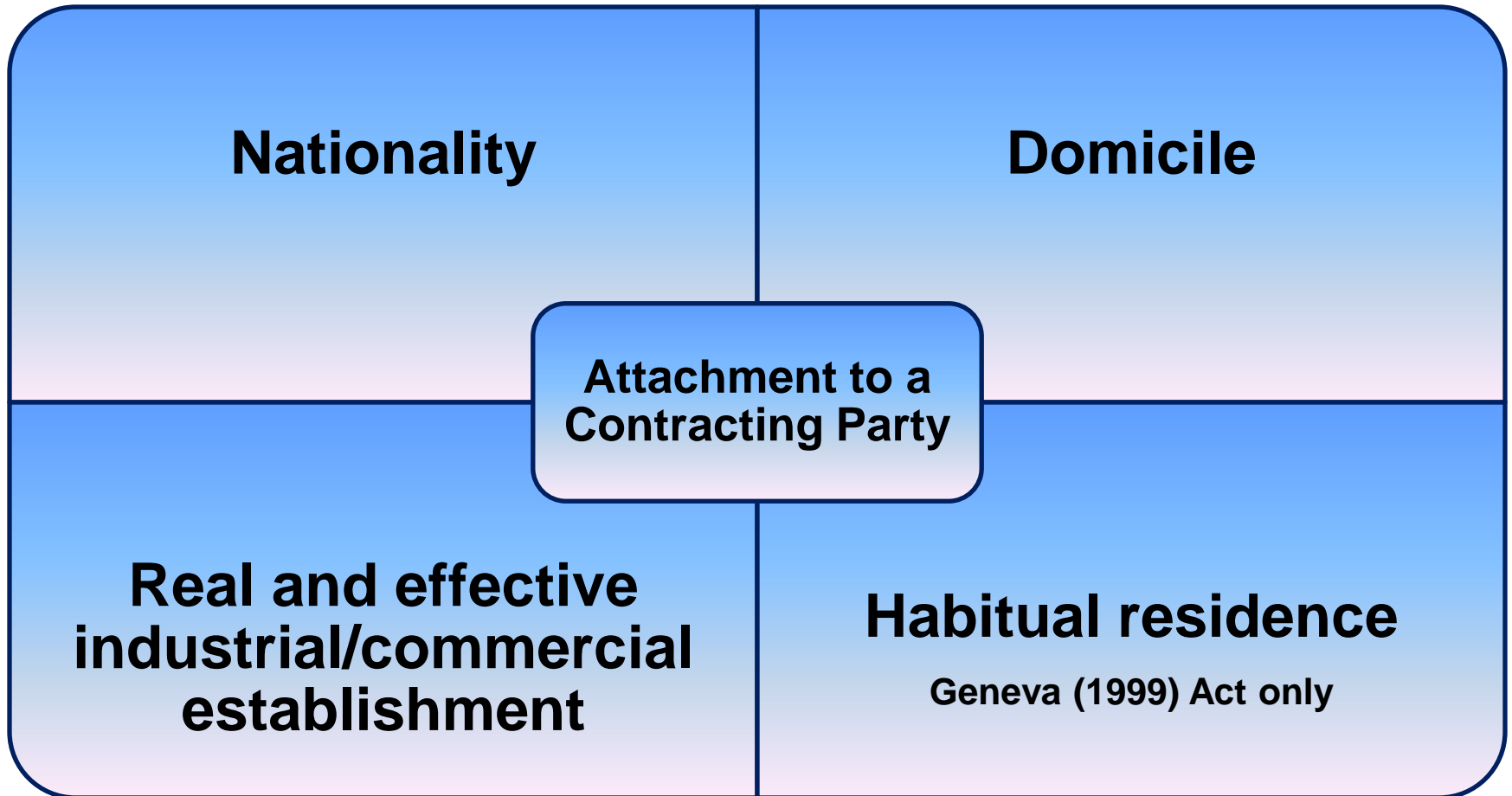

# The International Application

**In English, French or Spanish**

**May be filed directly with the International Bureau through the E-filing interface but also on paper**

**May comprise several different designs up to a maximum of 100 if they belong to the same class of the International Classification (Locarno)**

**One set of fees (in CHF) is to be paid**



# The Hague System Procedure: Role of the International Bureau

Formal examination

Recording in the International Register

Sending the certificate to the holder

Publication in the International Designs Bulletin

Notification to members through publication  
in the Bulletin

# The Hague System Procedure

## Refusal by a designated Contracting Party

on same substantive grounds as for national/regional filings

must be communicated within time limit

effect limited to territory of the member that has refused

## International registration (where not refused)

no refusal = same rights as a national/regional design registration

a bundle of independent national/regional rights

advantages of central management

# The Hague System Procedure

Duration of protection:  
**five years**

**Renewable** at  
least **once**  
(1960 Act) or  
**twice** (1999 Act)

**Longer renewal period**, if allowed  
by the law of the  
designated  
**Contracting Party**

# General Advantages



## Hague System (international route)

one Office for filing  
one language  
one currency  
one international registration  
one renewal  
one modification  
foreign attorney or agent  
(first needed if refused)



## National/regional route

many Offices for filing  
many languages  
many currencies  
many registrations  
many renewals  
many modifications  
foreign attorney or agent  
(first needed at filing)



- **Common Regulations (1996)**  
*last revised: January 1, 2017 (in force)*
- **Administrative Instructions (2002)**  
*last revised: July 1, 2014*
- **National Laws and Regulations**

# Hague Union

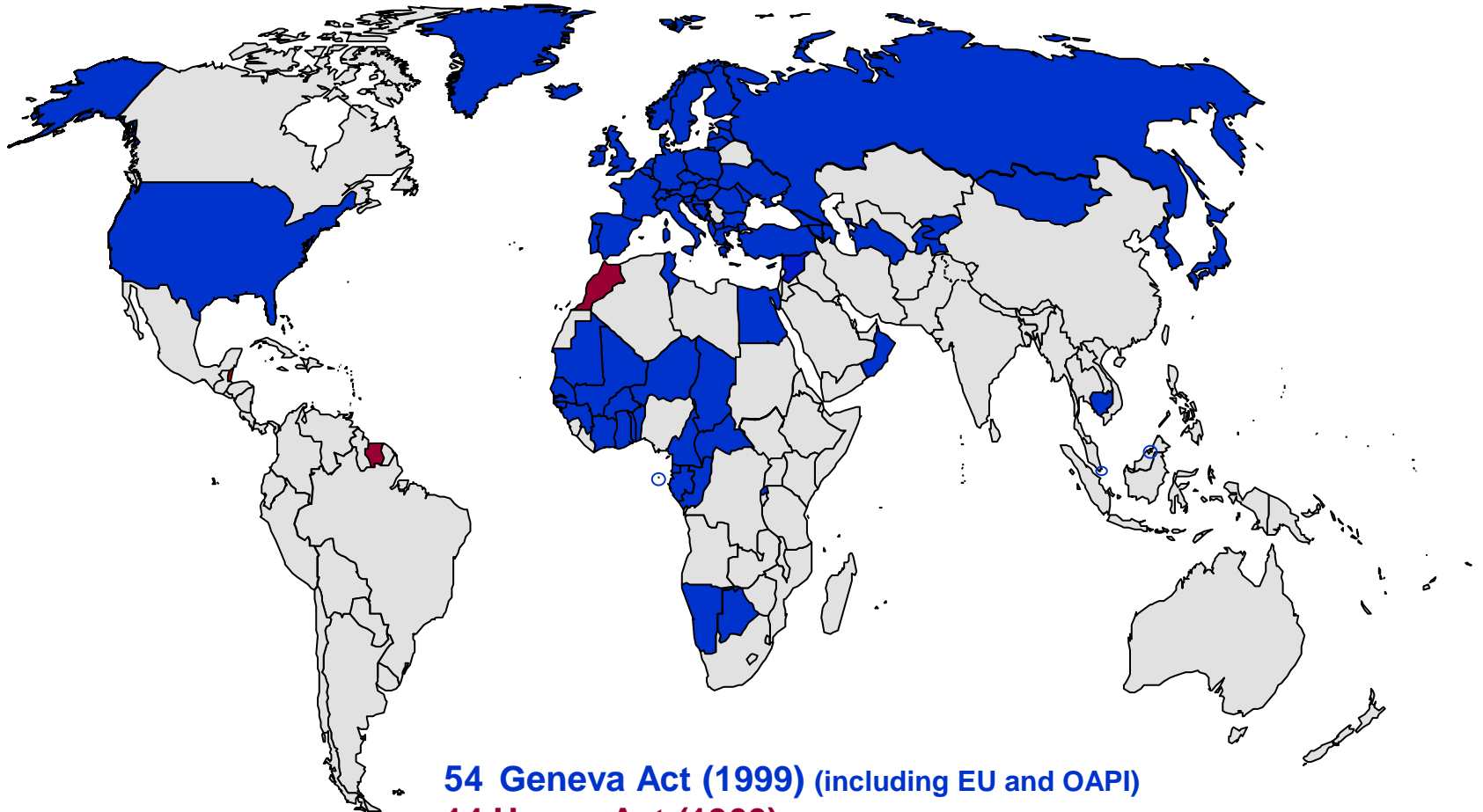

**54 Geneva Act (1999) (including EU and OAPI)**

**14 Hague Act (1960)**

**68 Contracting Parties**

# Geneva Act (1999)

## Recent Accessions



**United Kingdom\***  
(March 13, 2018)



**Russian Federation**  
(November 30, 2017)



**The Kingdom of Cambodia**  
(November 25, 2016)



**D.P.R. of Korea**  
(June 13, 2016)



**United States of America**  
(February 13, 2015)



**Japan**  
(February 13, 2015)



**Republic of Korea**  
(March 31, 2014)

## Potential Accessions



**China**



**Morocco**



**ASEAN countries**



**Israel**



**Canada**



**Mexico**



**Madagascar**



**Belize**

\*The Geneva (1999) Act of the Hague Agreement will come into force in respect of the United Kingdom on June 13, 2018.

# Hague Membership (31.12.2017)

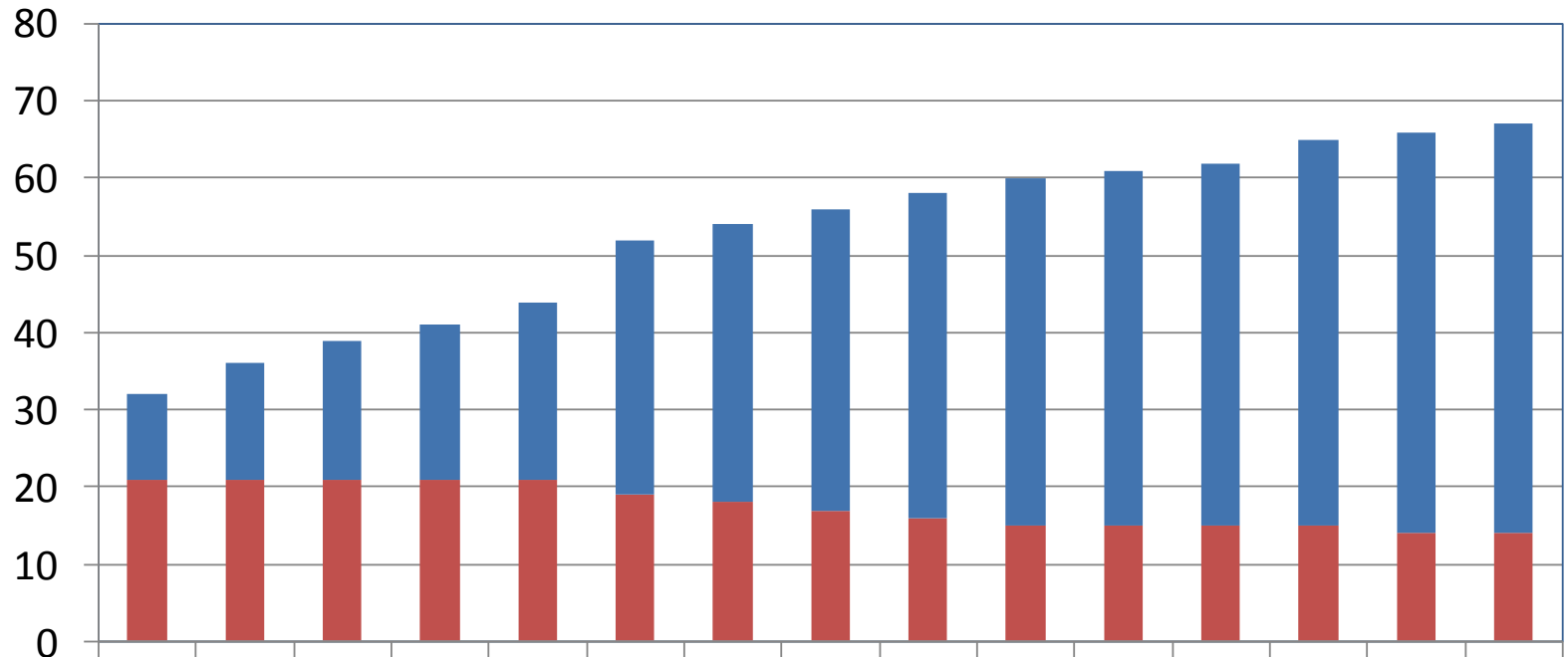

	2003	2004	2005	2006	2007	2008	2009	2010	2011	2012	2013	2014	2015	2016	2017
■ 1999 Act	11	15	18	20	23	33	36	39	42	45	46	47	50	52	53
■ 1960 Act	21	21	21	21	21	19	18	17	16	15	15	15	15	14	14



# International Registrations

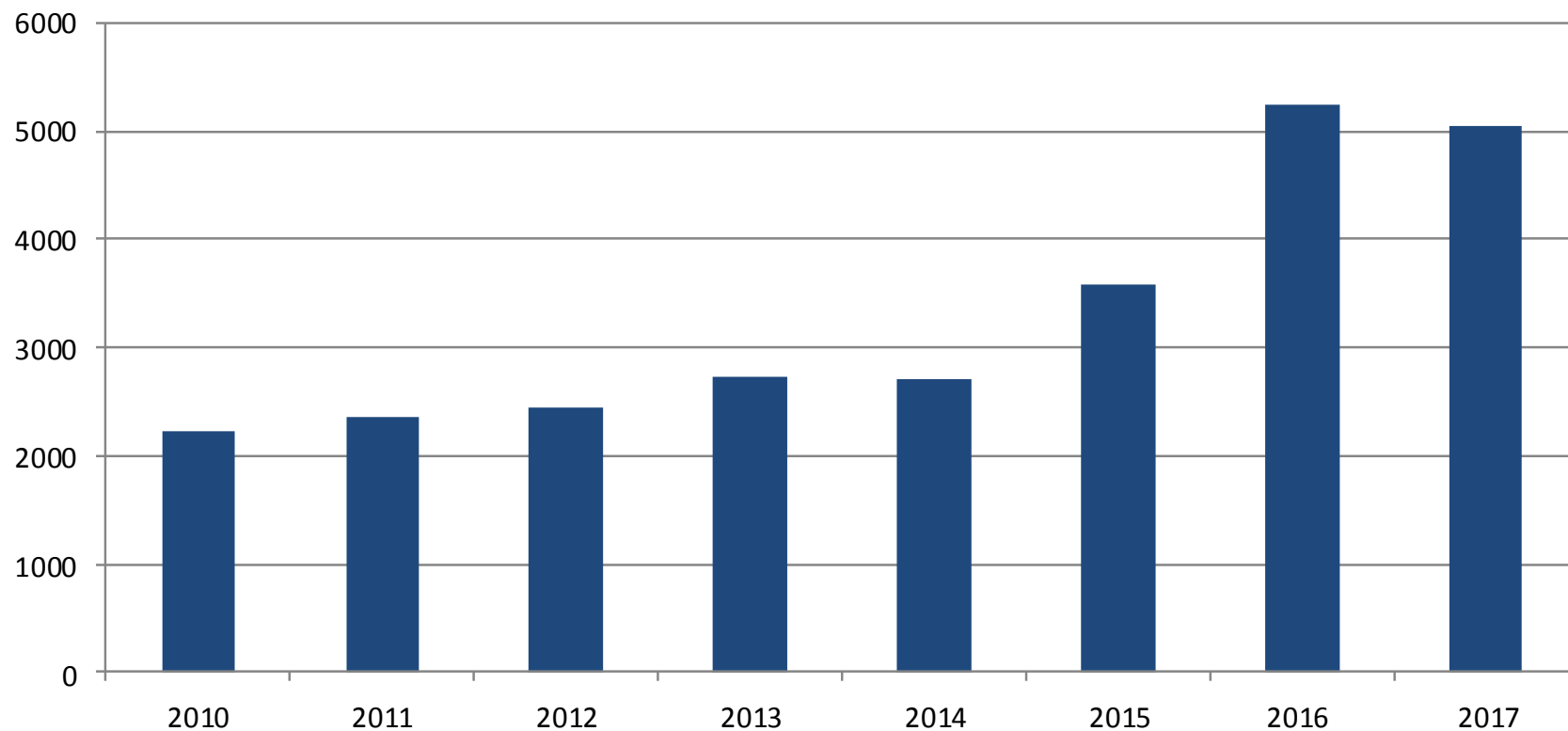

Interna. Reg. Recorded	2216	2363	2440	2734	2703	3581	5233	5041
Growth	11.7%	6.6%	3.3%	12.0%	-1.1%	32.5%	46.1%	-3.7%

# International Registrations (2017)



**5,041 international registrations were inscribed containing 19,241 designs**



**3.66% decrease compared to the respective period in 2016 in the number of registrations**



**9.3% increase compared to the respective period in 2016 in the number of designs**

# International Applications (2017)



**5,213 international applications were received containing 19,429 designs**



**6.27 % decrease compared to 2016 in the number of applications**



**3.8% increase compared to 2016 in the number of designs**

# Five Most Popular Classes (2017)



**Class 14**

Recording, communication or  
information retrieval equipment  
**579 registrations (11.5%)**



**Class 12**

Means of transport or hoisting  
**451 registrations (9.0%)**



**Class 6**

Furnishing  
**368 registrations (7.3%)**



**Class 10**

Clocks and watches and other measuring  
instruments, checking and signaling  
instruments  
**363 registrations (7.2%)**



**Class 26**

Lighting apparatus  
**326 registrations (6.5%)**

# Top 10 Applicants (2016)

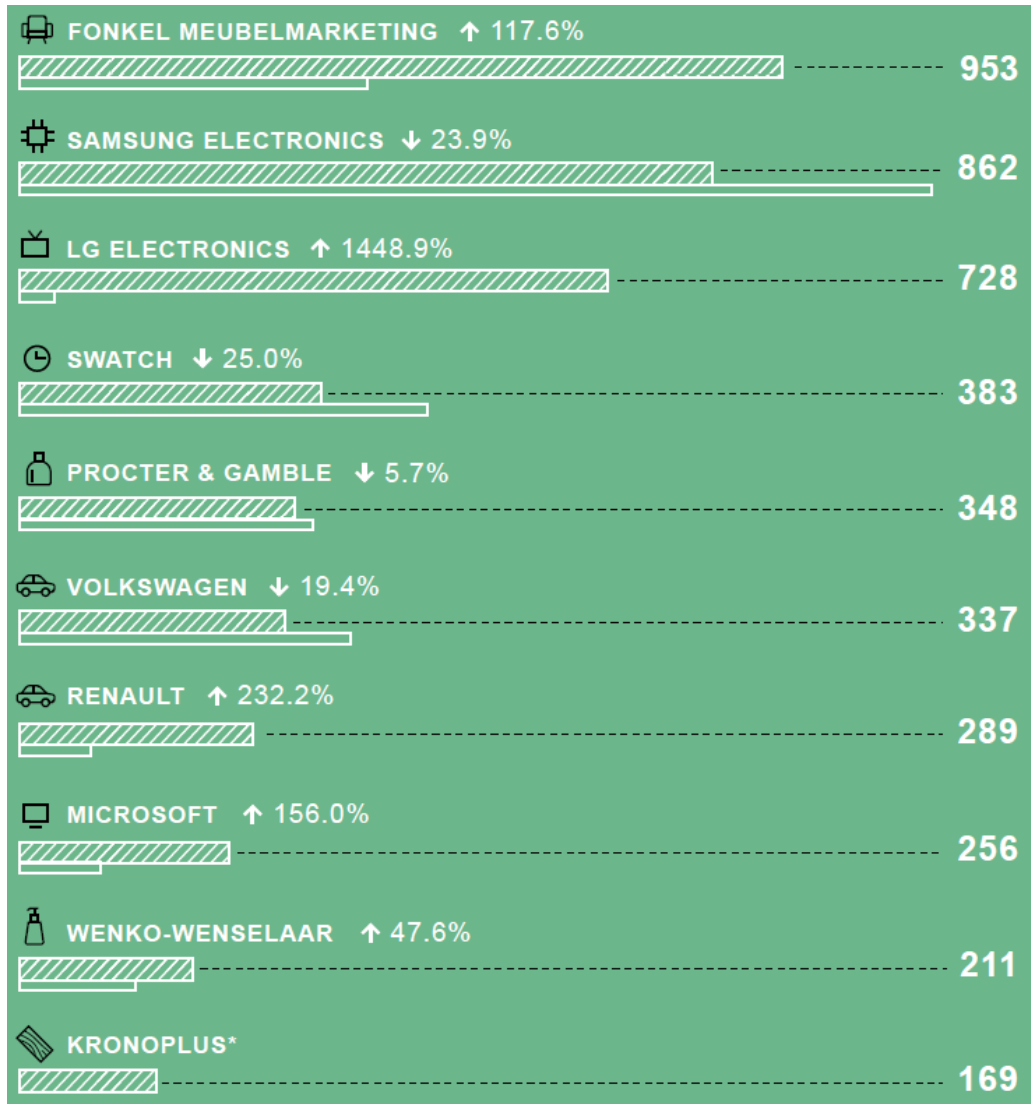

\* Fonkel Meubelmarketing (Netherlands) No 1 Filer



# Most Designated Contracting Parties (International registrations) 2017

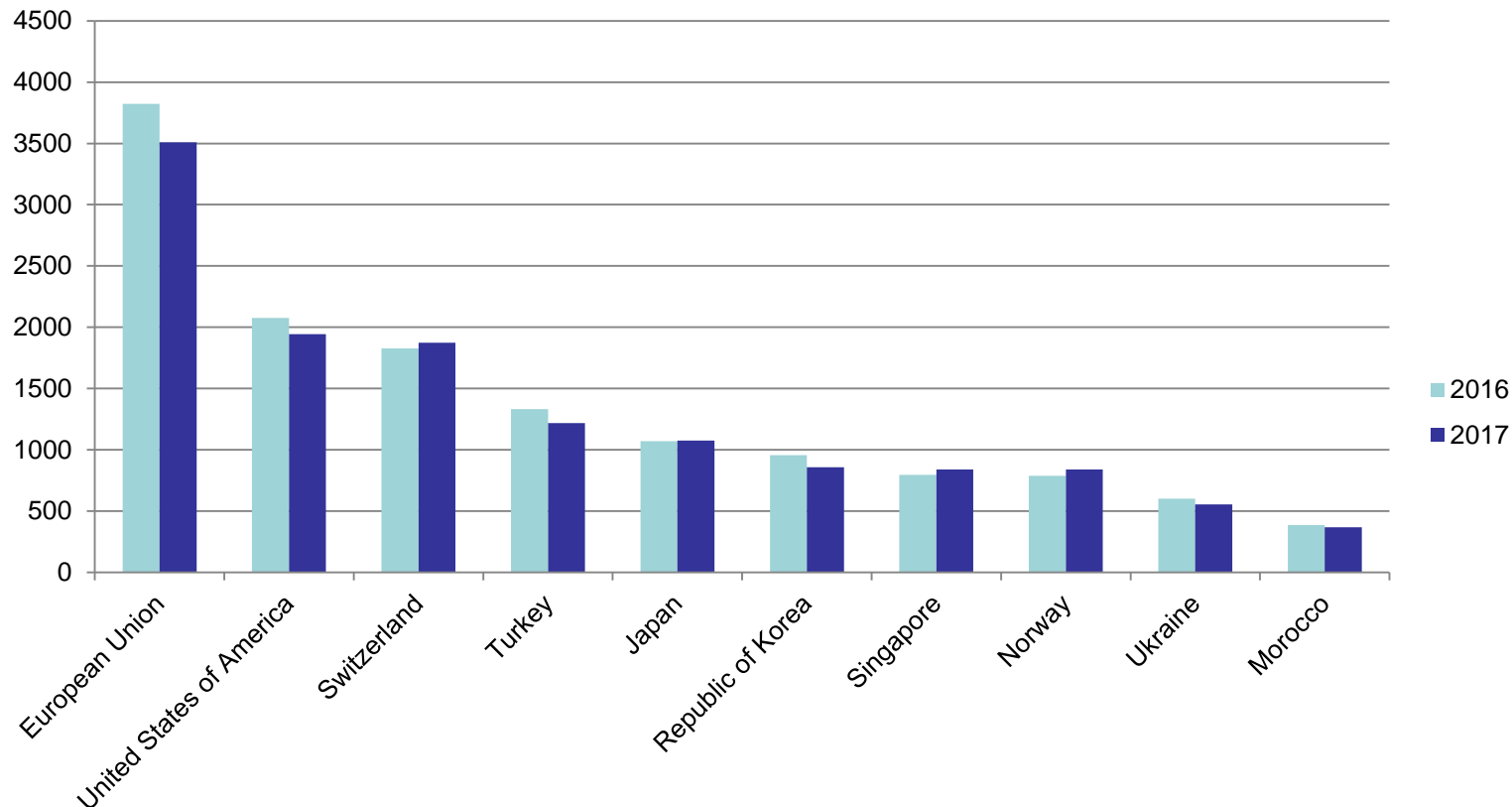

\* Since the effective accession (May 13, 2015)

# Most designated Contracting Parties (number of designs recorded) 2017

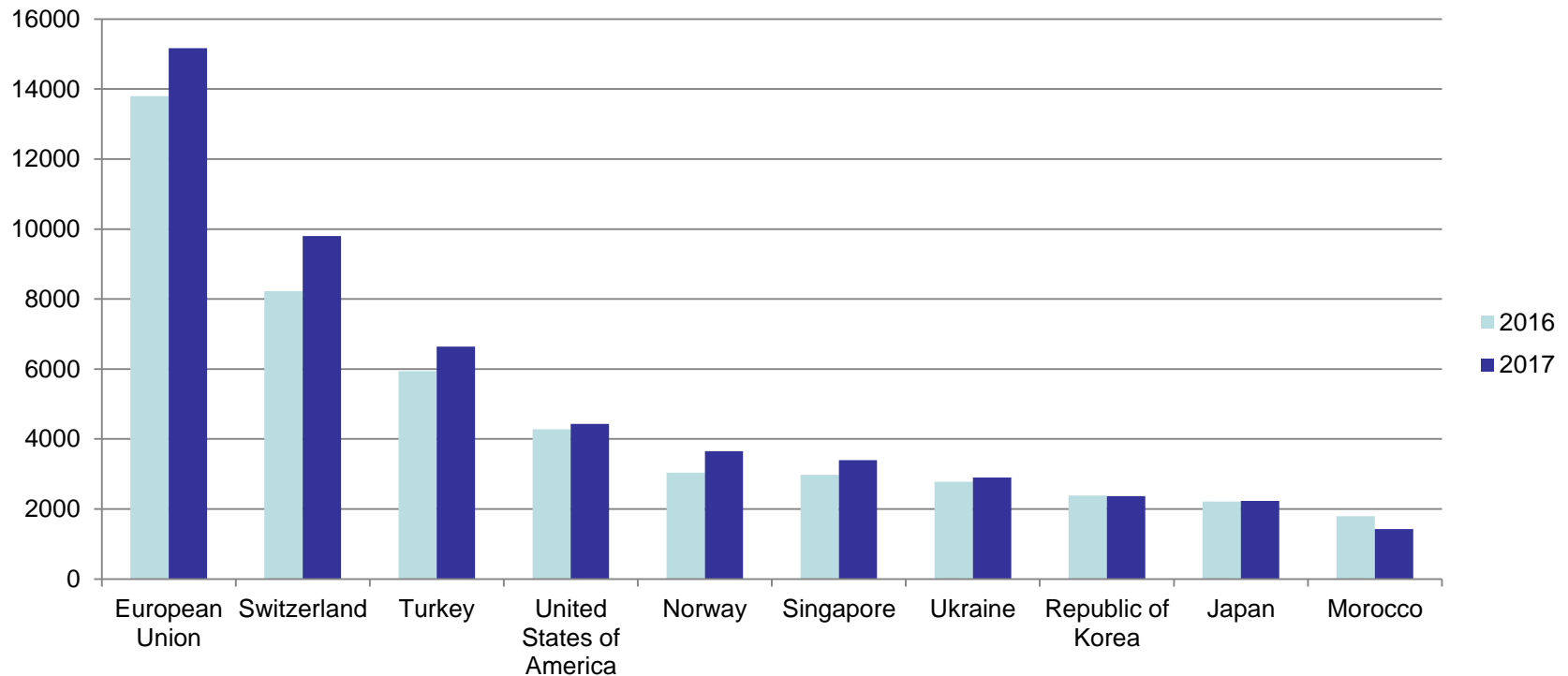

# International Registrations in force International Register (31.12.2017)

## Industrial Designs

**Right-holders**  
**(9,805)**



Industrial designs by right-holder	Number of right-holders	
1 design	<b>6558</b>	67.19%
2 designs	<b>1360</b>	13.87%
3-10 designs	<b>1498</b>	15.28%
11-100 designs	<b>328</b>	3.35%
> 100 designs	<b>31</b>	0.32%
<b>All</b>	<b>9805</b>	<b>100.00%</b>

**Registrations in force**  
**(34,324)**

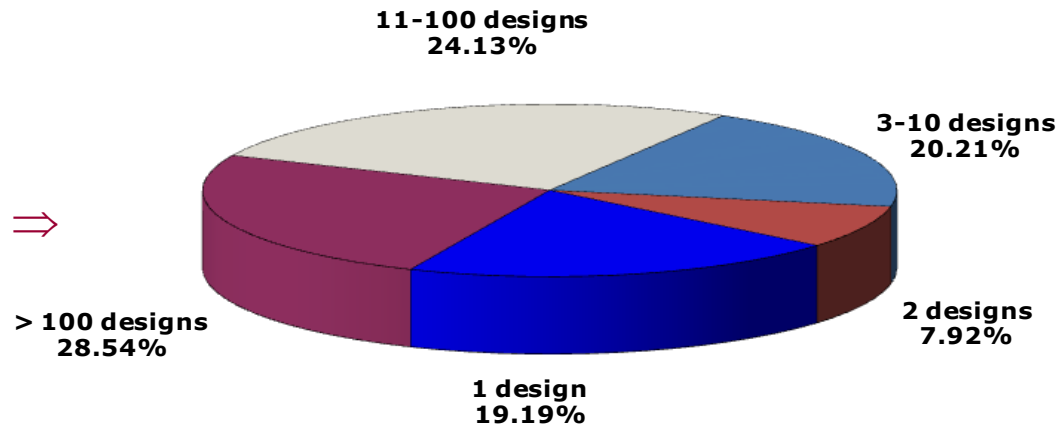



# Latest Developments



Regularization of international applications online (March 2016)



Guidance on reproductions



New Hague Express Database (January 2015)



Improvement of the E-filing interface



Developments in the legal framework

# Guidance on Reproductions

Prepared in consultation with Examining Offices under the Hague System and several user organizations

Detailed guidance on how to prepare and provide reproductions to overcome the most common refusal issues

- *Not enough views*
- *Unclear representations of the claimed design*
- *Unclear relief or contours of surfaces of a three-dimensional product*
- *Difference in form/color between the representations of the claimed design*

Information on which guidance should be taken into account when designating specific Contracting Parties

Not self-sufficient or all inclusive

Guidance on Preparing and Providing Reproductions in Order to Forestall Possible Refusals on the Ground of Insufficient Disclosure of an Industrial Design by Examining Offices available at:

[http://www.wipo.int/edocs/hagdocs/en/2016/hague\\_2016\\_9.pdf](http://www.wipo.int/edocs/hagdocs/en/2016/hague_2016_9.pdf)

# Disclosure Test: Reproduction Examples

1.1



1.1) Perspective

1.2



1.2) Perspective

**D089713 – Hilti Aktiengesellschaft**

1.3

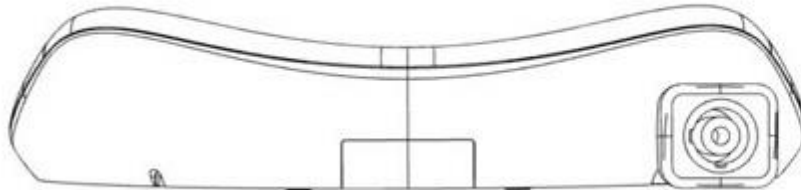

1.3) Back

1.4

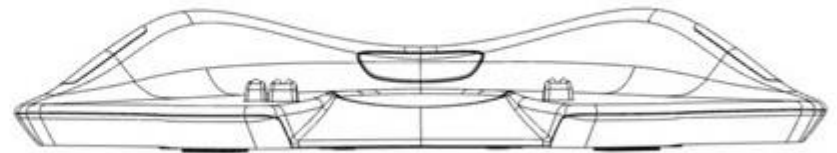

1.4) Front

**D087535 – Softbank Robotics**

# Disclosure Test: Reproduction Examples

1.2



1.2) Back

1.3



1.3) Left

1.4



1.4) Right

**D089858 – Ninebot (Beijing) Tech**

1.1

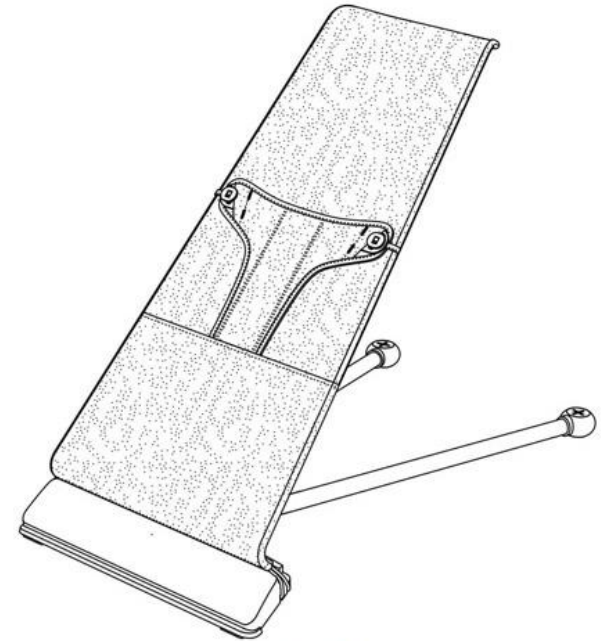

1.1) Perspective

**D086974 – Babybjörn AB**

# Hague Express Database

## Hague Express

The Hague Express Database, updated weekly, includes bibliographical data and, as far as international registrations governed exclusively or partly by the 1999 and/or by the 1960 Act(s) of the Hague Agreement are concerned, reproductions of industrial designs relating to international registrations that have been recorded in the International Register and published in the International Designs Bulletin as of issue No. 1/1999. International registrations that have lapsed are not removed from the database.

### SEARCH BY

Design Names Numbers Dates Country

Indication of Products =

Locarno =

Description =

search ↗

### CURRENT SEARCH

PROD:watch ✕

### FILTER BY

Designation Locarno Class Reg. Date \* Contracting Party \*

CH	1,535	MC	1,131	TN	991	MA	963	LI	960
FR	894	DE	890	IT	889	EG	887	BX	851
BE	851	NL	851	LU	851	ES	813	ME	684
MK	683	GR	666	MD	642	MN	634	SG	611
TR	594	UA	591	ID	586	EM	583	KP	556
RS	523	VA	489	SI	462	CW	409	BQ	408
SX	406	GE	380	RO	378	KG	376	BZ	364

Display: List Sort: Count - desc





filter ▼

1 - 10 / 1,627

edit columns ↔

10 per page

1 / 163

Reg. No	Holder	Reg. Date	Locarno Cl	Ind. Prod.	Des.	Designs	Image
DM/046674	HYSEK JÖRG	1999-02-03	03-01	Etui pour montre	AN,EG,ES,ID,MA,TN,V	1	
DM/082429	CARTIER CREATION STUDIO SA	2013-12-13	10-02	1. Watch; 2. Watch case; 3. Watch dial; 4. Watch; 5. Watch bracelet; 6. Watch dial; 7. Watch dial	CH,EM,SG,TR	8	
DM/083367	FRANCK MULLER WATCHLAND SA	2014-04-09	10-02	1. Montre-bracelet	EM,MC,SG	1	
DM/065362	SWATCH AG (SWATCH SA) (SWATCH LTD.)	2004-05-12	10-02	1. Montre-bracelet	BQ,CW,EG,ID,SX,TN,I	1	
DM/073485	BÉDAT & CO SA	2010-03-26	10-02	Watch	BX,KP,CH,EM,LI,OA,S	1	
DM/073351	HUBLOT SA, GENÈVE	2010-03-18	10-02	Watch	CH,EM,SG	1	
DM/073317	OMEGA SA (OMEGA AG) (OMEGA LTD.)	2010-02-12	10-02	Watch	BZ,MA,MC,ME,AL,AM,I	1	
DM/072570	ALEXIS BARTHELAY (SOCIÉTÉ ANONYME)	2009-10-20	10-02	Watch	MA,CH,EG,EM,OM,SG	1	

# Global Design Database

## Global Design Database

A world-wide collection of industrial designs data; including WIPO Hague registrations and information from participating national offices.

### SEARCH BY

Design Names Numbers Dates Country

Indication of Products ▾ =

Design class ▾ =

Description ▾ =

search ↗

### FILTER BY

Source Designation Locarno Class Reg. Year ✖

CA Designs	166,387	ES Designs	97,240	JP Designs	544,785	NZ Designs	47,479
US Designs	806,481	ID Designs	56,693	WO Designs	55,795		

Display: List ▾ Sort: Value - asc ▾

filter ▾

1 - 10 / 1,774,860

Display: 10 per page options

1 / 177,486

Reg. No	Source	Holder	Reg. Date	Locarno Cl.	National Cl.	Ind. Prod.	Designations	Designs	Image
D0807718	USID	SUMITOMO ELECTRIC HARDMETAL CORP.	2018-01-16	08-03	US.D08-020	Cutting tool	US	1	
D0807764	USID	Shallcross; Richard Scott	2018-01-16	10-04	US.D10-065	NPT/UN thread identification kit	US	1	
D0807777	USID	Fitbit, Inc.	2018-01-16	11-01	US.D11-094, US.D10-128	Receptacle insert for a wearable fitness band system	US	1	
D0807772	USID	EASYREAD TIME TEACHER LIMITED	2018-01-16	10-07	US.D10-126	Clock	US	1	
D0807795	USID	Brunswick Corporation	2018-01-16	12-16	US.D12-150 US.D09-434	Shock absorbing hub assembly for a marine propulsion apparatus	US	1	

# E-Filing Interface: Improvements



Receive and download notifications from the IB relating to international applications



Send corrections to irregularities or defects



Retrieve in real-time current status of IA



Indication of access code obtained from the IP office of first filing → access to priority document via the WIPO Digital Access Service (DAS) by designated IP office

# E-Filing Interface

WIPO reference

39014

- Applicant(s)
- Representative Correspondence
- Designation(s)
- Design(s)
- Related Design(s)
- Description
- Creator(s)
- Priority(ies)
- Exhibition(s)
- More Optional Contents
- Publication
- Signature
- Payment/Validat.
- Summary
-  Return to e-filing manager

## Information regarding data entry

Please continue on this page if you wish to register a new applicant. Otherwise, click on the next tab on the left.

## Information concerning the applicant

### Name and address

Name \*  Telephone

Address \*  Fax

Zip/Post code  E-mail address

Town\*  Address of website

Country\*

(\*) Compulsory

### Entitlements \*\*

Nationality

Domicile

Real and effective industrial or commercial establishment

Habitual residence

(\*\*) Indicate at least one entitlement



### Applicant's Contracting Party (ACP)

Applicant's Contracting Party

Save

Cancel

## Applicant(s) registered

Name	Address	Nat.	Dom.	Estab.	Res.	ACP	Act(s)	Actions
Yves Closet	34 Ch. des Colombettes 1211 Lausanne Switzerland	BX		EM		EM	60/99	 



# E-Filing Portfolio Manager

Welcome ASTON88 

## Portfolio Status

Number of application(s) sent: 46  
Number of application(s) unsent: 10



## E-Filing Manager Menu

E-Filing Application  
E-Filing Communications (0 unread)  
E-Filing Tutorial

File an international application | **Sent application(s)** | Unsent application(s)

## Application(s) sent to the International Bureau

(1 of 5) 

	WIPO reference ⇅	Filing date ⇅	Applicant(s) ⇅	Locarno Class ⇅	Designation(s) ⇅	Status ⇅	A.R.
1	WIPO4059	05/08/2016	Jack Smith	6	JP, KR, RS, SG, SN, SY, US	Examination	
2	WIPO4151	05/08/2016	New Designs SA	2	DE, ES, GH, JP, US	Registered	
3	WIPO4146	27/07/2016	Helen Williams	3	JP, KR, TR, UA, US	Abandoned	

# Developments in the Legal Framework

**Termination of the London (1934) Act of the Hague Agreement took place in October 2016**

**Amendments to the Common Regulations concerning safeguard against non-delivery of electronic communication (in force on 01.01.2017)**

**Entry into force of the eleventh edition of the Locarno Classification on 01.01.2017**

# New Hague Information Tools

New functionalities available at  
[www.wipo.int/hague](http://www.wipo.int/hague)

- **Contact Hague Form**
  1. Single point of contact for users
  2. History
  
- **Hague Member Profiles Database**
  1. Compilation of data
  2. Search tool

**Thank you  
for your attention**

[alexandra.grazioli@wipo.int](mailto:alexandra.grazioli@wipo.int)





# Il Sistema di Lisbona

## La registrazione e protezione internazionale delle denominazioni d'origine e delle indicazioni geografiche



Ms. Alexandra Grazioli, Director, Lisbon Registry, Law and Legislative Advice Division, Brands and Designs Sector, WIPO

**Brescia, Italia, 10 Aprile, 2017**

# Presentazione

- **Le Indicazioni Geografiche**

- **La situazione a livello internazionale**

*Il Sistema di Lisbona ed il nuovo Atto di Ginevra (2015)*

# **Cosa sono le indicazioni geografiche ?**





# Denominazione “GARDA” per Olio di oliva

- **Luogo d’origine specifico**
- **Caratteristiche specifiche**  
*(fattori naturali ed umani)*



# Cosa sono le indicazioni geografiche?

Un'**indicazione** che identifica un **prodotto** come originario di una **specifica area geografica** e le cui qualità, caratteristiche o reputazione sono **essenzialmente** attribuibili a tale origine geografica



**GARDA**



# IG = Interazione tra prodotto, produttori e area di produzione



## AREA DI PRODUZIONE

Influenza delle condizioni naturali → il prodotto è generalmente diverso da quelli prodotti altrove

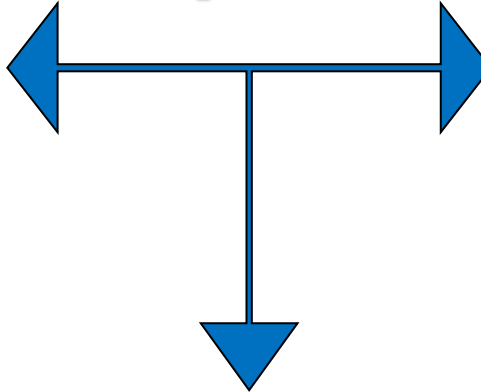

## KNOW-HOW DEI PRODUTTORI

I prodotti IG sono spesso prodotti tradizionali con una connessione al patrimonio e alle conoscenze locali



## PRODOTTO CON NOME SPECIFICO E SPECIFICHE QUALITÀ O REPUTAZIONE

→ I consumatori collegano direttamente le specifiche caratteristiche e qualità del prodotto alla sua origine geografica

# **Come proteggere le indicazioni geografiche nei mercati dei paesi terzi ?**

# Diversi strumenti di protezione delle indicazioni geografiche

## ■ Legislazioni *Sui generis*



## ■ Sistemi Marchi (marchi collettivi / di certificazione)



## ■ Sistemi amministrativi (etichettatura, etc.)

## ■ Legislazione sulla concorrenza sleale

# Come proteggere le IG all'estero?

## ■ Domande di registrazione dirette in paesi terzi

*Domanda individuale*

## ■ Accordi bilaterali o plurilaterali

*Attraverso tali accordi due o piu' Stati o partner commerciali si accordano per proteggere le rispettive IG (standard di protezione + frequentemente lista di IG)*

## ■ Accordi multilaterali

- **Accordo TRIPS (OMC)**

*Protezione delle IG*

- **Protocollo/Accordo di Madrid (WIPO)**

*Registrazione di Marchi*

- **Accordo di Lisbona e Atto di Ginevra (WIPO)**

*Protezione e registrazione di Denominazioni d'Origine (DO) e IG ai sensi dell'Atto di Ginevra*

# Il Sistema di Lisbona

- *Accordo di Lisbona (1958)*
- *Atto di Ginevra (2015)*

# L'Accordo di Lisbona in sintesi...

- Stabilito per facilitare la protezione internazionale delle denominazioni d'origine (DO) attraverso una **singola procedura di registrazione** (*“semplice ed accessibile”*)
- Amministrato da WIPO che mantiene il **Registro Internazionale delle Denominazioni d'Origine**



# L'Accordo di Lisbona in sintesi...

## ■ Protezione **illimitata** in **tutte le parti contraenti dell'accordo**

- eccezione: rifiuto, invalidazione, dichiarazione di protezione e
- fino a quando la DO è protetta nel paese di origine

## ■ **Alto livello di protezione delle** DO registrate negli altri paesi di Lisbona

(contro ogni tipo di **usurpazione** o **imitazione**)

## ■ Le DO registrate **non possono diventare generiche** negli altri paesi di Lisbona

## ■ Titolo per intraprendere **azione legale**

**Domanda per registrazione internazionale**  
*(da autorità competente del paese di origine)*

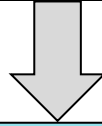

**Registrazione nel registro internazionale e pubblicazione (WIPO)**  
e  
**Notificazione della registrazione a tutte le parti contraenti (WIPO)**

**Rifiuto della protezione**  
**(totale/parziale)**  
*(un anno)*

**Notificazione di**  
**concessione della**  
**protezione (opzionale)**

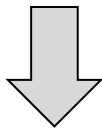
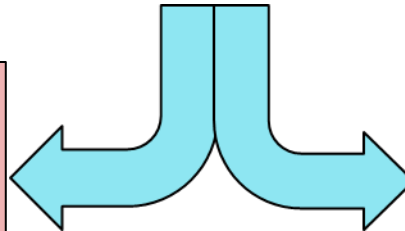

**Ritiro del rifiuto**  
**(totale/parziale)**  
o  
**Notificazione della**  
**protezione**



**Periodo di Transizione**  
*(2 anni)*

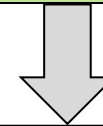

**Invalidazione**  
o  
**Rinuncia**

# Copertura geografica:

Domanda singola = protezione in 28+1 Paesi  
ed altri a seguire

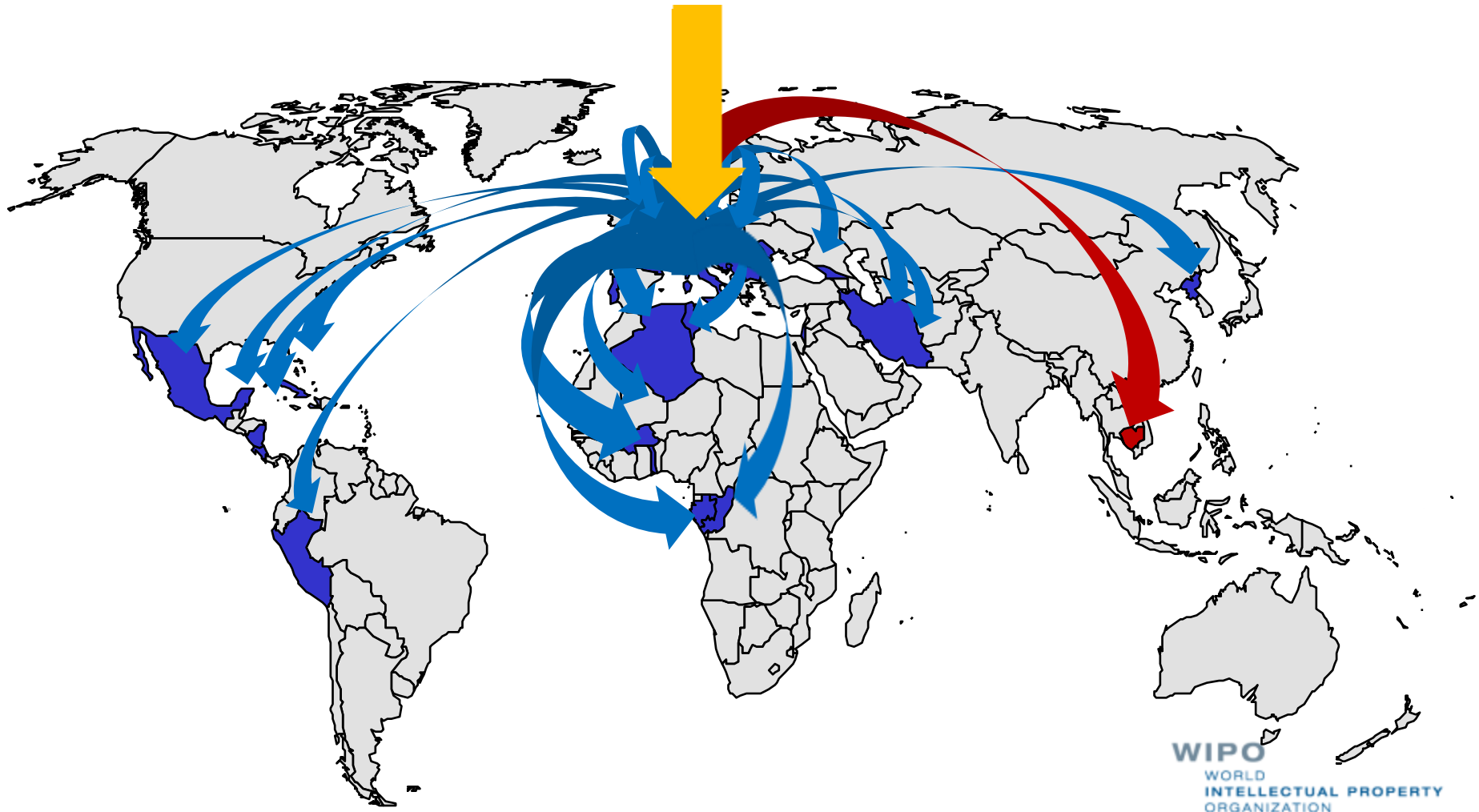

# Unione di Lisbona: 28+1 Paesi membri

## Europe (13)

Bosnia e Erzegovina

Bulgaria

Repubblica Ceca

Francia

Georgia

Ungheria

**Italia**

Moldavia

Montenegro

Portogallo

Serbia

Slovacchia

ERY di Macedonia

## Asia (3)

**Cambogia**

*(Atto di Ginevra)\**

Rep. Islamica dell'Iran

Israele

RPD di Corea

## America (6)

Costa Rica

Cuba

Haiti

Messico

Nicaragua

Perù

## Africa (6)

Algeria

Burkina Faso

Congo

Gabon

Togo

Tunisia

# 1111 registrations – 1005 in force

■ Algeria	7	■ <b>Italia</b>	<b>174</b>
■ Bulgaria	51	■ <b>Messico</b>	<b>15</b>
■ <i>Bosnia-Erzegovina</i>	2	■ Montenegro	2
■ Costa Rica	1	■ Perù	8
■ <b>Cuba</b>	<b>20</b>	■ Portogallo	7
■ ERY di Macedonia	5	■ Rep. di Moldavia	1
■ <b>Francia</b>	<b>509</b>	■ RDP di Corea	6
■ <b>Georgia</b>	<b>28</b>	■ <b>Rep. Ceca</b>	<b>75</b>
■ <b>Ungheria</b>	<b>28</b>	■ Serbia	3
■ <i>Iran (Rep. Islamica)</i>	<b>47</b>	■ Slovacchia	8
■ Israele	1	■ Tunisia	7

(Marzo 2018)

# Esempi di Denominazioni d'Origine nel Registro di Lisbona



**TEQUILA**  
(669 / Messico)



**CAFE VERACRUZ**  
(840 / Messico)



**BANANO DE COSTA RICA**  
(900 / Costa Rica)



**PROSCIUTTO DI PARMA**  
(843 / Italia)



**VAZISUBANI** (871 / Georgia)



**SAROUGH HANDMADE  
CARPET** (956 / Iran)



**CHULUCANAS** (869 / Perù)

# Esempi di registrazioni italiane ai sensi dell'Accordo di Lisbona



(AO 519) VALPOLICELLA



(AO 932) NOCCIOLA DEL PIEMONTE /  
NOCCIOLA PIEMONTE



(AO 924) ASIAGO



(AO 961) ACETO BALSAMICO  
TRADIZIONALE DI MODENA



(AO 960) POMODORO DI PACHINO



(AO 1052) LIMONE DI SIRACUSA

# Denominazioni d'Origine registrate

The *LISBON EXPRESS* database

The *AO Bulletin*



Il bollettino “*Appellations of origin*” è la pubblicazione ufficiale del Sistema di Lisbona. È pubblicato da WIPO per render note le nuove registrazioni ed altre operazioni relative al registro internazionale oltre alle informazioni concernenti i cambi nella struttura giuridica del sistema di Lisbona. Inoltre, il bollettino contiene informazioni statistiche sulle denominazioni d'origine registrate.





**The Geneva Act of the Lisbon Agreement  
on Appellations of Origin  
and Geographical Indications  
of May 20, 2015**

# Origine della Revisione

***Migliorare il sistema di Lisbona per renderlo **piu' attrattivo** per gli utilizzatori e per i potenziali nuovi membri,***

***preservando al contempo i principi e gli obiettivi dell'Accordo di Lisbona.***

(Fonte LI/A/25/3, para. 19(i))

# Atto di Ginevra dell'Accordo di Lisbona su Denominazioni d'Origine ed Indicazioni Geografiche

- **Adottato il 20 Maggio 2015**

- 54 firmatari dell'Atto finale (*Cina, Rep. Ceca, Francia, Germania, Grecia, Ungheria, **Italia**, Lettonia, Messico, Perù, Romania, Federazione Russa, Svizzera, African Intellectual Property Organization, Unione Europea, etc.*)

- 15 firmatari

(*Bosnia e Erzegovina, Burkina Faso, Congo, Costa Rica, Francia, Gabon, Ungheria, **Italia**, Mali, Nicaragua, Perù, Portogallo, Repubblica di Moldavia, Romania, Togo*)

- Entrerà in vigore con **cinque** accessioni/ratifiche



# Le novità dell'Atto di Ginevra

1. Possibilità di adesione per le **organizzazioni intergovernative**
2. Definizione di **indicazione geografica**
3. Rafforzato il riconoscimento dei diversi mezzi di **protezione delle DO** e delle **IG** a livello nazionale e regionale (*sui generis, marchi, etc.*)
4. Specificazione delle **eccezioni** e **limitazioni** della protezione
5. Possibilità di richiedere il **pagamento di tasse individuali**

# Adesione delle organizzazioni intergovernative



- **Unione Europea**  
**28 Stati Membri**



- **Organizzazione Africana della Proprietà Intellettuale (OAPI)**  
**17 Stati Membri**

# Le novità dell'Atto di Ginevra

1. Possibilità di adesione per le **organizzazioni intergovernative (OIG)**
2. Definizione di **indicazione geografica**
3. Rafforzato il riconoscimento dei diversi mezzi di protezione delle DO e delle IG a livello nazionale e regionale (*sui generis, marchi, etc.*)
4. Specificazione delle **eccezioni e limitazioni** della protezione
5. Possibilità di richiedere il **pagamento di tasse individuali**

# IP, IG, DO: quale è la differenza ?

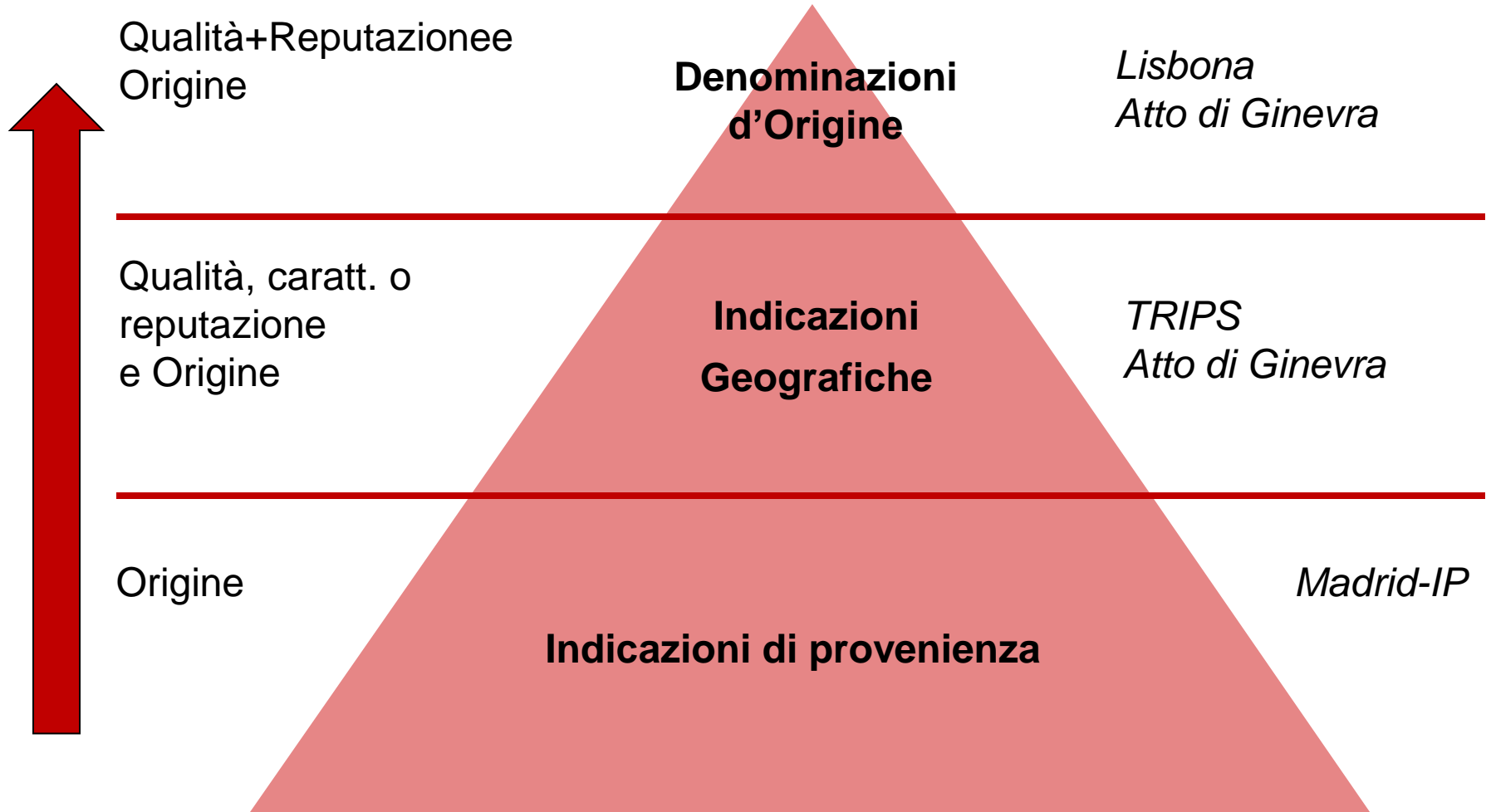

# Protezione delle IG



Cacao de Tonga  
Cacao de Ngoumou  
(Cameroun)



Darjeeling Tea  
(India)



Toiles de Korhogo  
(Côte d'Ivoire)



Kopi Luwak Coffee  
(Indonesia)



Miel de Rodrigues  
(Maurice)



Ananas Pain de Sucre  
(Benin)



Huile d'Argan  
(Maroc)



Jamaican Jerk  
(Jamaica)



# Le novità dell'Atto di Ginevra

1. Possibilità di adesione per le **organizzazioni intergovernative (OIG)**
2. Definizione di **indicazione geografica**
3. **Rafforzato il riconoscimento dei diversi mezzi di protezione delle DO e delle IG a livello nazionale e regionale (*sui generis, marchi, etc.*)**
4. Specificazione delle **eccezioni e limitazioni** della protezione
5. Possibilità di richiedere il **pagamento di tasse individuali**

# Diversi strumenti di protezione delle indicazioni geografiche

## ■ Legislazioni *Sui generis*



## ■ Sistemi Marchi (marchi collettivi / di certificazione)

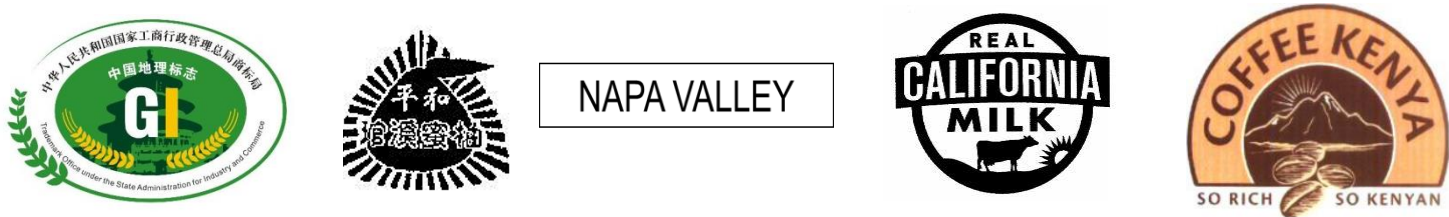

## ■ Sistemi amministrativi (etichettatura, etc.)

## ■ Legislazione sulla concorrenza sleale

# Flessibilità rispetto agli strumenti di protezione

- **Flessibilità** rispetto al **tipo di legislazione** in base alla quale una parte contraente protegge le DO/IG registrate (*sui generis, marchi, etc.*) (**Art.10**)
- **Flessibilità** rispetto **alla qualifica di richiedente** (**Art.5.2**) (*persona legittimata ad utilizzare una DO/IG; persone che possono far valere i diritti degli utilizzatori o altri diritti sulle DO/IG*)
- **Depositi diretti** da parte dei beneficiari dei diritti (**Art.5.3**)
- Possibilità di richiedere una dichiarazione di **intenzione d'uso** (**Rule 5.4**)
- Nuova definizione della **portata della tutela** (**Art.11**)

# Portata della tutela (Articolo 11(1)(a)(i)e(2))

- Strumenti giuridici per prevenire l'uso rispetto a **prodotti dello stesso tipo**

New

- **che non provengono** dall'area geografica di origine, o
- **che non rispettano** ogni altra condizione applicabile per utilizzare la DO o l'IG

- Strumenti giuridici per prevenire ogni uso equivalente alla **imitazione** della DO o IG, anche quando la **vera origine** dei prodotti è indicata o se la DO/IG è usata in **forma tradotta**, o quando la DO/IG è accompagnata da termini quali **“stile”**, **“tipo”**, etc.

# Portata della tutela (Articolo 11(1)(a)(ii)&(2))

- Strumenti giuridici per prevenire l'uso rispetto a prodotti **che non sono dello stesso tipo** o **servizi**, laddove tale uso:
  - suggerisca una **connessione** con i beneficiari della DO/IG ed è probabile che **danneggi** i loro interessi, o
  - ove applicabile, quando tale uso **indebolisca** o **diluisca** in maniera sleale, o **tragga un indebito vantaggio** della **reputazione** della DO/IG
- Strumenti giuridici per prevenire ogni uso equivalente alla **imitazione** della DO/IG, anche quando la **vera origine** dei prodotti è indicata o se la DO/IG è usata in **forma tradotta**, o quando la DO/IG è accompagnata da termini quali **“stile”, “tipo”, etc.**

New

# Protezione contro determinati usi (Article 11(1)(b) and (3))

New

- Ogni altra pratica capace di ingannare i **consumatori** sulla vera origine, la provenienza o la natura dei prodotti
- La parte contraente dovrà, *ex officio* se la sua legislazione lo permette o a richiesta di una parte interessata, **rifiutare o invalidare la registrazione di un marchio successivo** se l'uso di tale marchio ricade in una delle situazioni previste dall'Articolo 11(1)

# Genericità (Articolo 12)

■ Protezione contro la **genericità**

■ **Eccezioni:**

- **Uso precedente come termine generico** in una parte contraente è un possibile **motivo di rifiuto**
- se la DO/IG contiene un termine che è **considerato generico nella parte contraente di origine**, gli altri membri **non sono obbligati a proteggere tale termine**

New

# Le novità dell'Atto di Ginevra

1. Possibilità di adesione per le **organizzazioni intergovernative (OIG)**
2. Definizione di **indicazione geografica**
3. Rafforzato il **riconoscimento dei diversi mezzi di protezione delle DO e delle IG a livello nazionale e regionale** (*sui generis, marchi, etc.*)
4. **Specificazione delle eccezioni e limitazioni della protezione**
5. Possibilità di richiedere il **pagamento di tasse individuali**



# Eccezioni e Limitazioni

- Opportunità per le **parti interessate di richiedere il rifiuto della protezione (Art. 15)**
- **Garanzie** per:
  - Diritti di marchio anteriori **(Art. 13.1)**
  - Nomi di persona utilizzati nel commercio **(Art. 13.2)**
  - Denominazioni di varietà vegetali o specie animali **(Art 13.3)** e
  - Termini generici **(agreed statements, Rule 5.5)**

# Le novità dell'Atto di Ginevra

1. Possibilità di adesione per le **organizzazioni intergovernative (OIG)**
2. Definizione di **indicazione geografica**
3. Rafforzato il **riconoscimento dei diversi mezzi di protezione delle DO e delle IG a livello nazionale e regionale** (*sui generis, marchi, etc.*)
4. Specificazione delle **eccezioni e limitazioni** della protezione
5. Possibilità di richiedere il **pagamento di tasse individuali**

New

**Domanda per registrazione internazionale**  
*(da autorità competente del paese di origine + **domanda diretta**)*

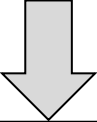

**Registrazione nel registro internazionale e pubblicazione (WIPO)**  
&  
**Notificazione della registrazione a tutte le parti contraenti (WIPO)**



**Rifiuto della protezione (totale/parziale)**  
*(un anno)*

**Notificazione di concessione della protezione (opzionale)**

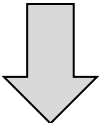

**Ritiro del rifiuto (totale/parziale)**  
o  
**Notificazione della protezione**

**Periodo di Transizione**  
*(2) anni → **15 anni***

New

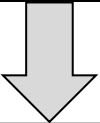

**Invalidazione**  
o  
**Rinuncia**

# Effetti legali della registrazione internazionale ai sensi dell'Atto di Ginevra

- **Alto livello di protezione delle IG e AO registrate negli altri membri dell'Unione di Lisbona**
- **Protezione in tutte le parti contraenti dell'Atto di Ginevra**  
*eccetto in quelle che hanno notificato un rifiuto / invalidazione / rinuncia di protezione*
- **Protezione indefinita**  
*fino a quando la IG o AO è protetta nella parte contraente di origine*

# L'Atto di Ginevra dell'Accordo di Lisbona un'opportunità per....



**LENTICCHIA DI ALTAMURA**  
(UE-IGP / Italy)



**MELONE MANTOVANO**  
(UE-IGP / Italy)



**MAIOLICHE DI DERUTA**



**PIZZOCCHERI DELLA VALTELLINA**  
(UE-IGP / Italy)



**COTECHINO MODENA**  
(UE-IGP ( Italy)



**MARMO DI BOTICINO**

# Lavori in corso sul Sistema di Lisbona...

- **Assemblee WIPO, Assemblea dell'Unione di Lisbona**
  - Adozione del Regolamento Comune
  - Sostenibilità finanziaria dell'Unione di Lisbona

*Ottobre 2017*

- **Gruppo di Lavoro sullo sviluppo del Sistema di Lisbona**
  - Sviluppo del Sistema di Lisbona
  - Sostenibilità finanziaria dell'Unione di Lisbona

*11 e 12 giugno 2018*

# Lavori in corso in WIPO...

- **Comitato Permanente sul Diritto dei Marchi, Didegno Industriale ed Indicazioni Geografiche**

- Indicazioni Geografiche

- Indicazioni Geografiche – nomi di dominio

+

- Marchi - Protezione di nomi di paesi

*prossimo meeting: 23 - 26 aprile 2018*

**Grazie!**

**[alexandra.grazioli@wipo.int](mailto:alexandra.grazioli@wipo.int)**

**Piu' informazioni sul Sistema di Lisbona:  
[www.wipo.int/lisbon/en/](http://www.wipo.int/lisbon/en/)**





*Ministero  
dello Sviluppo Economico*



UNIVERSITY  
OF BRESCIA



**WIPO**

WORLD  
INTELLECTUAL PROPERTY  
ORGANIZATION

# Global Databases for IP and Tools for the Connected Knowledge Economy



Mr. Christophe Mazenc, Director, Global Databases Division,  
Global Infrastructure Sector

**Brescia, Italy, April 10, 2018**

# Strategic Goals of Global Databases and Tools

■ 2 related goals:

■ “Coordination and Development of Global IP Infrastructure”

■ “World Reference Source for IP Information and Analysis”

# WIPO Knowledge Network (Concept)

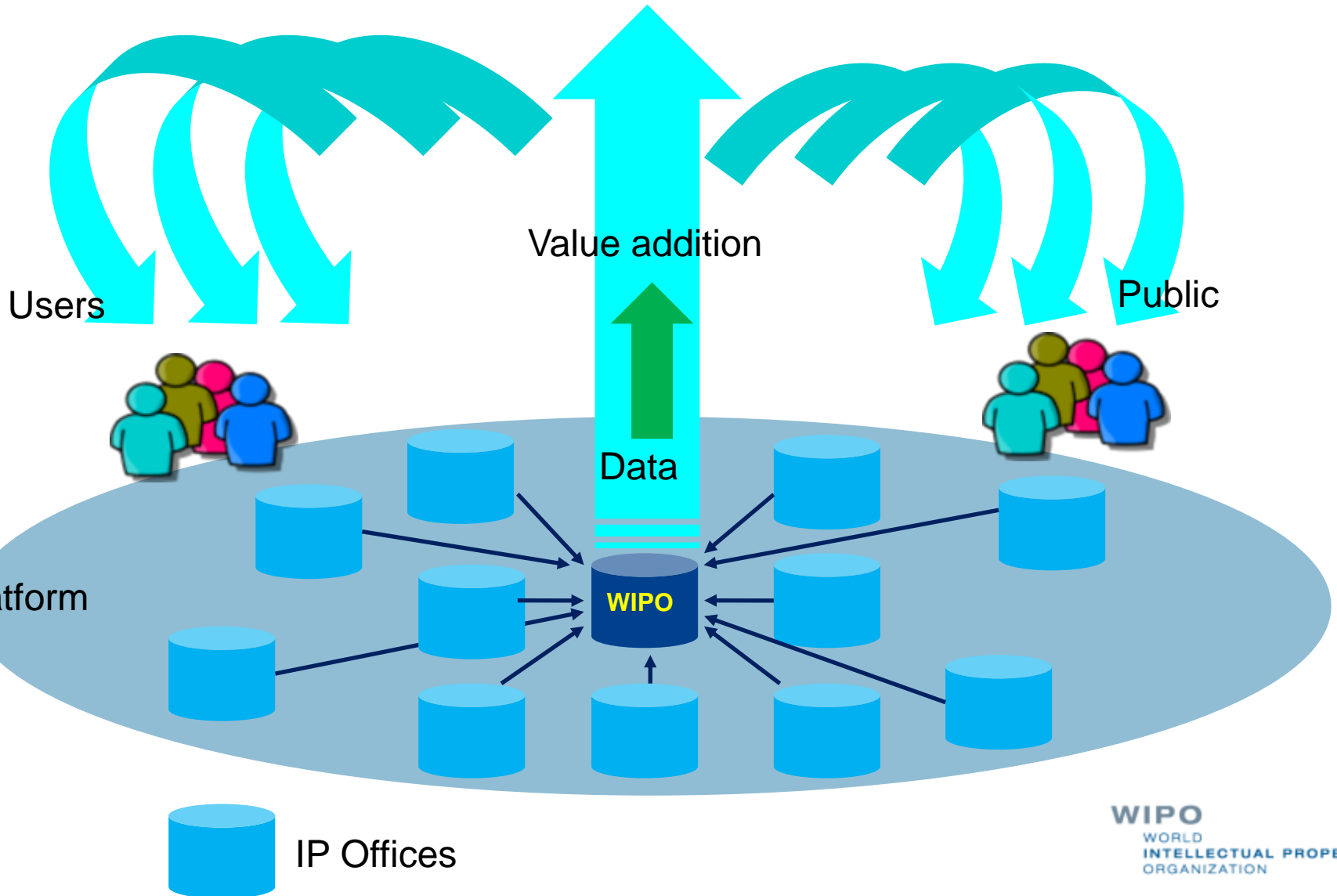

# GLOBAL DATABASES, TOOLS, AND PLATFORMS FOR IP BUSINESS (FREE)



- PATENTSCOPE
- Global Brand Database
- Global Design Database
- WIPO Lex
- WIPO Pearl

# PATENTSCOPE Summary

- 3.3 million published PCT applications (first publish every week, high quality full text)
- 69 million patent applications from 50+ countries or regions
- Full text data from 20 countries or regions
- 35,000 unique users per day
- Analyze results by graphs and charts
- Search and read in your language

# PATENTSCOPE Key features



The screenshot displays the WIPO PATENTSCOPE website. At the top left is the WIPO logo, and to its right is the PATENTSCOPE logo. A language selection bar includes links for Mobile, Deutsch, Español, Français, 日本語, 한국어, Português, Русский, and 中文. Below this is the tagline "Search International and National Patent Collections". A navigation bar contains links for Search, Browse, Translate, Options, News, Login, and Help. A red arrow points to the "Search" link, which has opened a dropdown menu with the following options: Simple, Advanced Search, Field Combination, and Cross Lingual Expansion. The "Cross Lingual Expansion" option is highlighted in yellow. Below the menu, a text box states "35 million patent documents including 2.2 million published international patent applications (PCT). Found here (->)". At the bottom of the interface, there is a search input field with a "Front Page" dropdown menu on the left, a search button labeled "Office: All Search" on the right, and a help icon.

Input search terms

Query

[\[Help\]](#)

electric car

- » Query Language: English
  - » Expansion Mode: English
  - » Precision:  Recall
- Submit Query

- English
- French
- German
- Spanish
- Portuguese
- Japanese
- Russian
- Chinese
- Korean
- Italian
- Swedish
- Dutch

Electric car  
only 16,000 hits

Search Query  
(synonyms &  
technologically  
related terms)

Results 1-10 of 153,538 for Criteria: (EN\_TI:(("electric car" OR "electric vehicle" OR "electrical motor" OR "hybrid car" OR "electric vehicular"~21 OR "electric automobile"~21) OR EN\_AB:(("electric car" OR "electric vehicle" OR "electrical motor" OR "hybrid car" OR "electric vehicular"~21 OR "electric automobile"~21)) OR (DE\_TI:(("Elektrofahrzeug" OR "Elektroauto" OR "Elektromotors" OR "Elektroautos" OR "Hybridfahrzeug" OR "Hybridautomobil" OR "elektrisches Fahrzeug") OR DE\_AB:(("Elektrofahrzeug" OR "Elektroauto" OR "Elektromotors" OR "Elektroautos" OR "Hybridfahrzeug" OR "Hybridautomobil" OR "elektrisches Fahrzeug")) OR (ES\_TI:(("vehículo eléctrico" OR "motor eléctrico" OR "vagón eléctrico" OR "coche eléctrico" OR "carro eléctrico" OR "automóvil eléctrico" OR "vehículo híbrido") OR ES\_AB:(("vehículo eléctrico" OR "motor eléctrico" OR "vagón eléctrico" OR "coche eléctrico" OR "carro eléctrico" OR "automóvil eléctrico" OR "vehículo híbrido") OR (FR\_TI:(("véhicule électrique" OR "voiture électrique" OR "auto électrique" OR "moteur électrique" OR "véhicule hybride" OR "voiture hybride") OR FR\_AB:(("véhicule électrique" OR "voiture électrique" OR "auto électrique" OR "moteur électrique" OR "véhicule hybride" OR "voiture hybride")) OR (JA\_TI:(("電動車両" OR "電気自動車" OR "ハイブリッド自動車" OR "ハイブリッドカ" OR "電気車" OR "ハイブリッド車" OR "ハイブリッドカー") OR JA\_AB:(("電動車両" OR "電気自動車" OR "ハイブリッド自動車" OR "ハイブリッドカ" OR "電気車" OR "ハイブリッド車" OR "ハイブリッドカー")) OR (KO\_TI:(("전기자동차" OR "전기 차량" OR "전동 차량" OR "전기차" OR "차량의제어" OR "하이브리드 자동차와아이" OR "전기 모터 제어" OR "전기 모터" OR "하이브리드 자동차용")) OR KO\_AB:(("전기자동차" OR "전기 차량" OR "전동 차량" OR "전기차" OR "차량의제어" OR "하이브리드 자동차와아이" OR "전기 모터 제어" OR "전기 모터" OR "하이브리드 자동차용")) OR (PT\_TI:(("veículo elétrico" OR "veículo eléctrico" OR "automóvel eléctrico" OR "veículo elétrico" OR "motor eléctrico") OR PT\_AB:(("veículo elétrico" OR "veículo eléctrico" OR "automóvel eléctrico" OR "veículo elétrico" OR "motor eléctrico")) OR (RU\_TI:(("электрической автомобиля"~22 OR "электрической средства"~22 OR "электрической вагона"~22 OR "электроподвижного автомобиля"~22 OR "электроподвижного транспортных средств"~22 OR "электроподвижного средства"~22 OR "электроподвижного вагона"~22 OR "электротранспорта") OR RU\_AB:(("электрической автомобиля"~22 OR "электрической транспортных средств"~22 OR "электрической средства"~22 OR "электрической вагона"~22 OR "электроподвижного автомобиля"~22 OR "электроподвижного транспортных средств"~22 OR "электроподвижного средства"~22 OR "электроподвижного вагона"~22 OR "электротранспорта")) OR (ZH\_TI:(("电车" OR "电动车辆" OR "电动汽车" OR "电动机动" OR "用于电动机动" OR "混合动力汽车" OR "混合动力车发电") OR ZH\_AB:(("电车" OR "电动车辆" OR "电动汽车" OR "电动机动" OR "用于电动机动" OR "混合动力汽车" OR "混合动力车发电")) Office(s):all Language:EN Stemming: true

prev 1 2 3 4 5 6 7 8 9 10 next Page:1 / 15354 Go >

Refine Search  Search RSS

Analysis

Sort by: Relevance View All List Length 10

No	Ctr	Title	PubDate	Int.Class	Appl.No	Applicant	Inventor
1.	WO	WO/2012/167518 - SOLAR HYBRID VEHICLE	13.12.2012	B60K 6/28	PCT/CN2011/079446	ZHU, Shuyi	ZHU, Shuyi

A solar hybrid vehicle comprises a vehicle body, a vehicle energy configuration system, and a braking energy recycling device (11). The vehicle body collects solar energy with a solar energy collection system, the collected solar energy is stored in the vehicle energy configuration system, and the braking energy recycling device is connected to a storage battery pack (6). A power is disposed between the vehicle energy configuration system and the storage battery pack. The vehicle







1. (WO2012167518) SOLAR HYBRID VEHICLE

- [PCT Biblio. Data](#)
- [Description](#)
- [Claims](#)
- [National Phase](#)
- [Notices](#)
- [Drawings](#)
- [Documents](#)

Latest bibliographic data on file with the International Bureau

PermaLink

**Pub. No.:** WO/2012/167518    **International Application No.:** PCT/CN2011/079446  
**Publication Date:** 13.12.2012    **International Filing Date:** 07.09.2011  
**IPC:** B60K 6/28 (2007.10), B60L 8/00 (2006.01)   
**Applicants:** ZHU, Shuyi [CN/CN]; (CN)  
**Inventors:** ZHU, Shuyi; (CN)  
**Agent:** BEIJING GENIUS ESSEN INTELLECTUAL PROPERTY OFFICE; Room 806 ~ 809 Taifeng Huizhong Mansion No.120 Zhushikou W. St., Xicheng District Beijing 100050 (CN)

**Priority Data:** 201110151619.9 08.06.2011 CN

**Title**  
 (EN) SOLAR HYBRID VEHICLE  
 (FR) VÉHICULE HYBRIDE SOLAIRE  
 (ZH) 太阳能混合动力汽车

**Abstract:** (EN) A solar hybrid vehicle comprises a vehicle body, a vehicle energy configuration system, and a braking energy recycling device (11). The vehicle body collects solar energy with a solar energy collection system, the collected solar energy is stored in the vehicle energy configuration system, and the braking energy recycling device is connected to a storage battery pack (6). A sensor is disposed between the vehicle energy configuration system and the storage battery pack. The vehicle energy configuration system is connected to an on-board automatic control system, an external charging interface (15) and an electric motor (7). The present invention combines multiple technical solutions, reduces energy consumption, increases the utilization of solar energy, and is more aesthetic and user-friendly.



图 1 / Fig. 1

(FR) La présente invention concerne un véhicule hybride solaire comportant une carrosserie de véhicule, un système de configuration d'énergie de véhicule, et un dispositif de recyclage d'énergie au freinage (11). La carrosserie de véhicule collecte de l'énergie solaire grâce à un système de collecte d'énergie solaire, l'énergie collectée est stockée dans le système de configuration d'énergie de véhicule et le dispositif de recyclage d'énergie au freinage est connecté à un bloc d'éléments d'accumulateur (6). Un capteur est disposé entre le système de configuration d'énergie de véhicule et le bloc d'éléments d'accumulateur. Le système de configuration d'énergie de véhicule est connecté à un système de commande automatique embarqué, à une interface de charge externe (15) et à un moteur électrique (7). La présente invention est une combinaison de plusieurs solutions techniques, réduit la consommation d'énergie, accroît l'utilisation de l'énergie solaire, et est plus esthétique et conviviale.

(ZH) 一种太阳能混合动力汽车, 包含汽车本体、车体能量配置系统、制动能量回收装置 (11); 汽车本体通过太阳能采集系统收集太阳能, 收集的太阳能存储在车体能量配置系统中, 制动能量回收装置与蓄

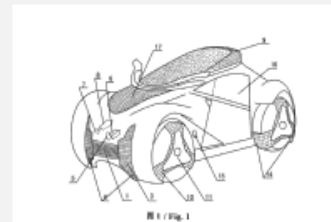

PCT Biblio. Data

Description

Claims

National Phase

1. (WO2012/000000)

Machine translation

Google Translate

Bing/Microsoft Translate

Baidu Translate

**Note:** Text based on automatic Optical Character Recognition. legal matters

太阳能混合动力汽车

技术领域

本发明涉及一种太阳能混合动力汽车，属于新能源汽车技术领域。

背景技术

随着国民经济的快速发展，越来越多的家庭已经或即将拥有汽车。但是，国际原油价格的一路飙升为我们敲响了能源紧缺的警钟。汽车在中国家庭中的普及要求我们在新能源汽车上取得实质性的技术突破。

目前，国内外众多科研机构、公司都在致力于新能源汽车的研究。其中，混合动力汽车是现有新能源汽车中最接近成熟的产品。混合动力汽车的性能可以超过传统的燃油汽车，但其电池蓄电量成为影响其发展的瓶颈，所以还不能完全取代燃油汽车。

在太阳能汽车的开发研究上，人们已经取得了较大的进展。近年来对太阳能收集转化技术的研究，也有效提高了太阳能的吸收利用率。太阳能汽车的车体玻璃对太阳能的有效吸收利用情况在很大程度上影响了汽车的整体性能。为此，人们在太阳能汽车上尝试使用可烘烤低辐射镀膜玻璃和太阳能薄膜电池来提高太阳能的吸收效率，并取得了一定的效果。

因此，借助技术的更新可以为市场提供更好的节能环保型太阳能混合动力汽车。

发明内容

本发明所要解决的技术问题在于克服现有技术的不足，提供一种太阳能混合动力汽车。

为实现上述的发明目的，本发明采用下述的技术方案：

一种太阳能混合动力汽车，包括汽车本体、太阳能采集系统、车体能量配置系统、车载自动控制系统和制动能量回收装置；

所述汽车本体通过所述太阳能采集系统收集太阳能；收集的太阳能储存在车体能量配置系统中，所述制动能量回收装置与蓄电池组连接；所述车体能量配置系统与所述蓄电池组之间设有传感器，所述车体能量配置系统分别与所述车载自动控制系统、外接充电接口和电动机相连；

所述太阳能采集系统包括太阳能天窗、可烘烤低辐射镀膜玻璃、太阳能薄膜电池以及车轮太阳能板，其中所述太阳能天窗为设置在所述汽车本体顶部的太阳能蜂窝吸光体；

在所述车体能量配置系统中，供电控制单元分别与光强检测单元、太阳能采集单元、能量存储单元、汽车用电单元连接，用于实时接收所述检测单元检测到的光强信号，并根据该光强信号控制所述太阳能采集单元、所述能量存储单元以及所述汽车用电单元的运行；

在所述汽车本体的车轮外侧分别设置有磁浮制动盘罩，所述磁浮制动盘罩的表面设置有车轮太阳能板；

1. (WO2012/00000)

PCT/IT/2011/00000

[PCT Biblio. Dati](#)[Descrizione](#)[Reclami](#)[Fase Nazionale](#)[Annunci](#)[Disegni](#)[Documentazione](#)

Translated by google

Italian

Powered by Google Translate

**Nota:** testo sulla base di processi automatici riconoscimento ottico dei caratteri. Si prega di utilizzare la versione PDF per questioni legali

Auto ibride solari

CAMPO

La presente invenzione riguarda un veicoli ibridi solari, appartenente al campo dei veicoli nuovi tecnologie energetiche.

BACKGROUND

Con il rapido sviluppo dell'economia nazionale, sempre più famiglie sono stati o stanno per avere una macchina. Tuttavia, i prezzi internazionali del greggio salito a noi ha lanciato l'allarme per la carenza di energia. Car popolare in famiglie cinesi ci impongono di fare sostanziali progressi tecnologici in nuovi veicoli di energia.

Allo stato attuale, molti istituti di ricerca nazionali ed esteri, le aziende stanno lavorando su veicoli di nuova energia. Tra questi, le auto ibride sono i veicoli di nuova energia più vicini esistenti maturano prodotto. Le auto ibride possono superare le prestazioni dei veicoli a combustibile tradizionale, ma la sua capacità della batteria è diventato un collo di bottiglia che interessano il loro sviluppo, in modo che non può sostituire completamente veicoli a carburante.

Sulla ricerca e lo sviluppo di automobili solari, le persone hanno fatto grandi progressi. Recenti studi sulla conversione della tecnologia solare raccolta di energia, ma anche di migliorare efficacemente l'assorbimento e l'utilizzazione dell'energia solare. Carrozzeria solare efficace assorbire vetro solare è largamente influenzato le prestazioni generali della macchina utilizzazione. Per questo motivo, si cerca di utilizzare la macchina solare può cuocere piegato bassa emissività vetro rivestito e celle solari a film sottile per migliorare l'efficienza di assorbimento di energia solare, e hanno raggiunto alcuni risultati.

Pertanto, l'uso di tecnologia aggiornata per fornire una migliore risparmio energetico veicoli ibridi solari al mercato.

SINTESI

I problemi tecnici da risolvere dalla presente invenzione è quello di superare le carenze della tecnica anteriore per fornire un veicoli ibridi solari.

Per raggiungere il suddetto scopo dell'invenzione, la presente invenzione impiega lo schema seguente tecnica:

A veicoli ibridi solari, tra cui il corpo vettura, il sistema di raccolta solare, i sistemi di configurazione di energia del corpo, i sistemi di controllo dei veicoli e il recupero dell'energia di frenata automatica;

# WIPO Translate



PATENTSCOPE

[English](#) | [Français](#) | [中文](#)

Translation Assistant for Patent Titles and Abstracts

[Home](#) > [IP Services](#) > [PATENTSCOPE](#) > [Database Search](#) > [Translation Assistant](#)

## Translate

[\[help/user guide\]](#)

This tool is based on statistics and trained only on patent titles and abstracts.  
You can cut and paste titles/abstracts from any patent application.

Source text:

Polymers which can be used in p-type materials for organic electronic devices and photovoltaic cells. Compounds, monomers, dimers, trimers, and polymers comprising formula (I) and/or formula (VIII) are prepared

Language pair:

- ...
- ...
- English->French
- French->English
- English->German
- German->English
- Japanese->English
- English->Japanese
- English->Chinese
- Chinese->English
- English->Korean (Beta)
- Korean->English (Beta)
- Russian->English
- English->Russian
- English->Spanish (Beta)
- Spanish->English

Domain:

Translate



Home > IP Services > PATENTSCOPE > Database Search > Translation Assistant

## Translate

[\[help/user guide\]](#)

This tool is based on statistics and trained only on patent titles and abstracts.  
You can cut and paste titles/abstracts from any patent application.

Source text:

Language pair:

Domain:

- [automatic detection]
- ADMN-Admin, Business, Management & Soc Sci
- AERO-Aeronautics & Aerospace Engineering
- AGRI-Agriculture, Fisheries & Forestry
- AUDV-Audio, Audiovisual, Image & Video Tech
- AUTO-Automotive & Road Vehicle Engineering
- BLDG-Civil Engineering & Building Construction
- CHEM-Chemical & Materials Technology
- DATA-Computer Sci, Telecom & Broadcasting
- ELEC-Electrical Engineering & Electronics
- ENGY-Energy, Fuels & Heat Transfer Eng
- ENVR-Environmental & Safety Engineering
- FOOD-Foods & Food Technology
- GENR-Generalities, Language, Media & Info Sci
- HOME-Home Contents & Household Maintenance
- HORO-Precision Mechanics, Jewelry & Horology
- MANU-Manufacturing & Materials Handling Tech
- MARI-Marine Engineering
- MEAS-Standards, Units, Metrology & Testing
- MECH-Mechanical Engineering

Translate

This tool is based on statistics and trained only on patent titles and abstracts.  
You can cut and paste titles/abstracts from any patent application.

Source text:

/ 一种页岩气作业方法、包括如下步骤：a、钻井；b、压裂；c、导出页岩气；d 将能够供给页岩气的井所输出的全部页岩气，或至少部分页岩气供给燃气发电机进行发电，并将所发出的电能输出至页岩气作业所使用的设备，或至少部分页岩气作业所使用的设备中改变了现有技术中、开采全程均用柴油发电机，或外界工业用电的方式进行供电的方式，实现“以气打气，气电结合”的方式、降低施工成本。 /

Language pair:

Chinese-&gt;English

Domain:

MECH-Mechanical Engineering

Translate

This automatic translation is provided for information only, it may contain discrepancies or mistakes and does not have any juridical value.

- Please hover your mouse over parallel segments of text
- Click to view other proposals
- Select words or phrases on the left to access other translations

一种页岩气作业方法、包括如下步骤：a、钻井；b、压裂；c、导出页岩气；d 将能够供给页岩气的井所输出的全部页岩气，或至少部分页岩气供给燃气发电机进行发电，并将所发出的电能输出至页岩气作业所使用的设备，或至少部分页岩气作业所使用的设备中改变了现有技术中、开采全程均用柴油发电机，或外界工业用电的方式进行供电的方式，实现“以气打气，气电结合”的方式、降低施工成本。 /

Edit translation

Choose among proposals, or edit the text

or at least partially shale gas operation of changing the equipment in the prior art, exploitation whole process are all made of diesel generator

Ok

or at least partially shale gas operation of changing the equipment in the prior art, exploitation whole process are all made of diesel generator

or at least partially shale gas operation of changing the equipment in the prior art, exploitation whole **course by** diesel generator

or at least partially shale gas operation of changing the equipment in the prior art, exploitation whole process **by** diesel generator

or at least partially shale gas operation of changing the equipment in the prior art, exploitation whole process of diesel generator

or at least partially shale gas operation of changing the equipment in the prior art, exploitation whole **course** are all made of diesel generator

# WIPO Translate: Neural Machine Translation

- NMT replaces gradually SMT
- Pilot system put in production in October 2016 on PATENTSCOPE for the ZH↔EN language pairs
- Now covers in addition the following language pairs:  
EN↔(AR, DE, ES, FR, JA, KO, PT, RU)
- NMT: better translation quality, better fluency, especially for “distant” language pairs

# Why is NMT different? (Phrase-based vs Neural-net)

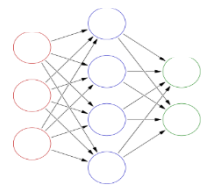

发明公布了一种通过在不同位置摆放现实物体来演奏音乐的娱乐装置



PBSMT (previous WIPO translate)

invention discloses	a by	placing a real object	at a	different location	to	play a music	entertainment device
---------------------	------	-----------------------	------	--------------------	----	--------------	----------------------



NMT (new WIPO translate)

the	invention discloses	an	entertainment device	for	playing music	by	placing real objects	at	different position
-----	---------------------	----	----------------------	-----	---------------	----	----------------------	----	--------------------



# Amazing comparative quality for patent texts

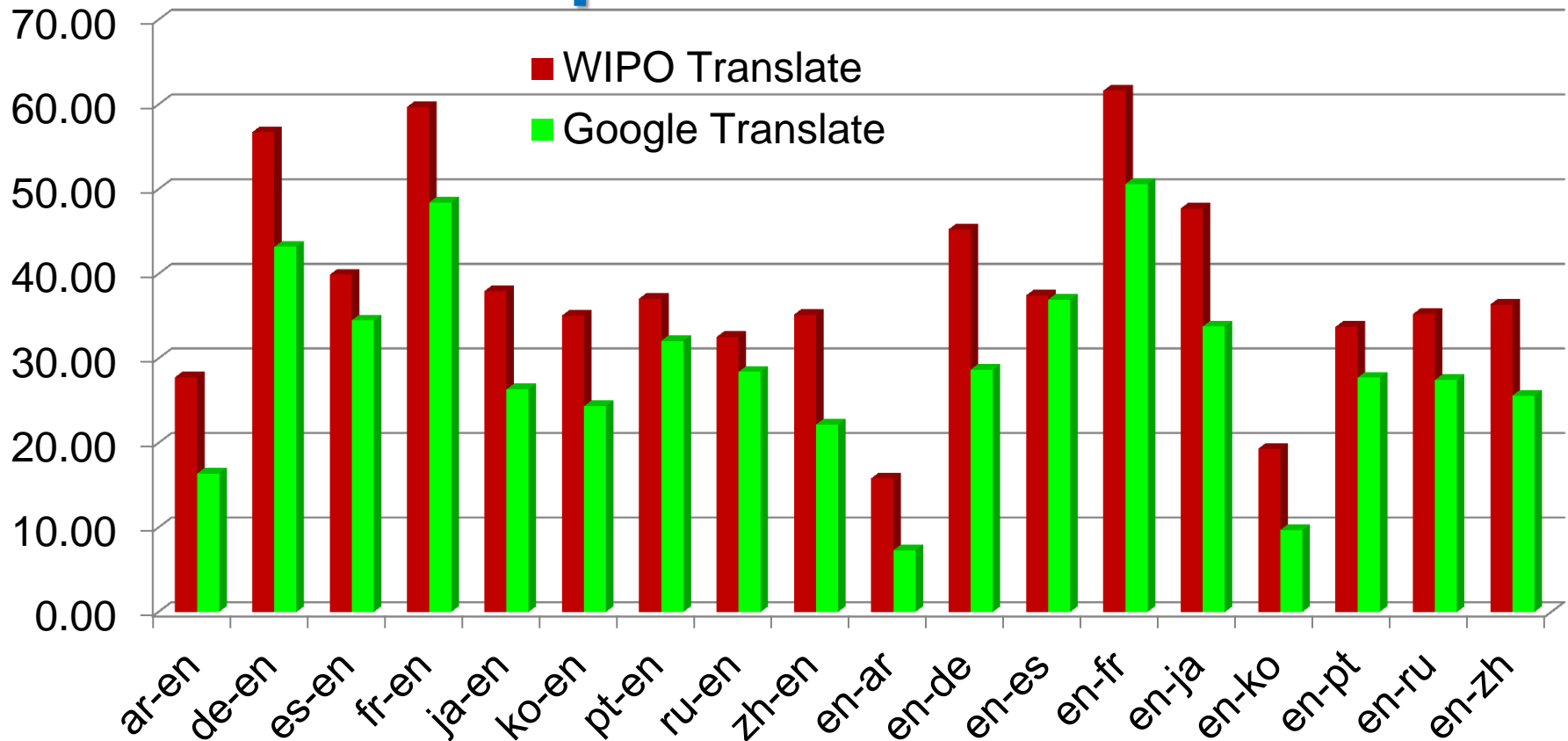

BLEU score comparison between WIPO Translate and Google Translate (both using NMT models), testset containing titles and abstracts from patents published after July 2017(except Arabic). Tested uniquely with new sentences NOT used in the training of WIPO Translate

# PATENTSCOPE latest additions (last 12 months)

- **Denmark:** 1895 to 2018: 400'000 applications
- **Australia:** 1959 to 2018: 1.6 million applications, bibliographic data and full text since 1993
- **Asean countries (only bibliographic data):**
  - **Brunei Darussalam:** 1'200 applications from 1985
  - **Cambodia:** 15 applications from 2015
  - **Philippines:** 20'000 applications from 2012
  - **Indonesia:** 115'000 applications from 1994
  - **Malaysia:** 150'000 applications from 1986
  - **Thailand:** 130'000 applications from 1981
- **India:** 1996 to 2016: 465'000 patent applications published from 2005 to 2018 (Bibliographic data only)

# Search chemical compounds



Principle:

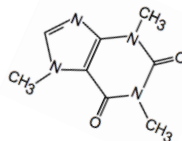

- Recognize chemical compounds in patent texts and from embedded drawings included in patent texts
- Standardize all the different representations of chemical structures into Inchikeys
- Implement search functions for Inchikeys that can be used by non chemists

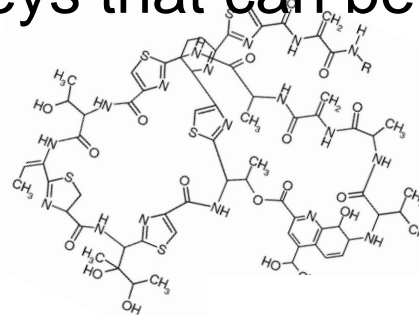
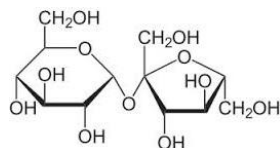

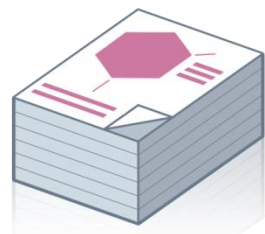

**PATENTSCOPE Documents**

(...) At the moment the surgical procedure starts, benzodiazepin, e.g. diazepam, is administered in a dose of no more than 5 mg. (...)

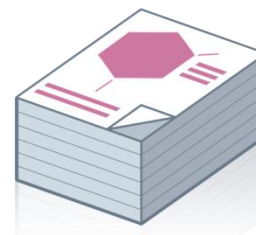

**Enriched PATENTSCOPE Documents**

(...) At the moment the surgical procedure starts, benzodiazepin, e.g. @AAOVKJBEBIDNHE-UHFFFAOYSA-N@, is administered in a dose of no more than 5 mg. (...)

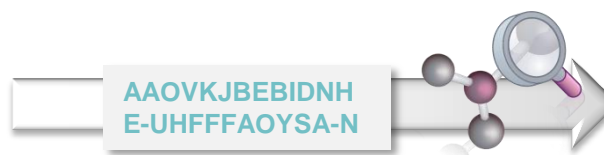
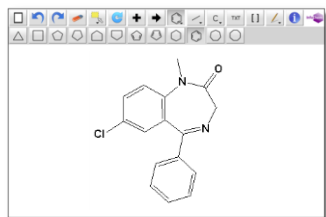

# Standardization

IUPAC name

N-(4-hydroxyphenyl)acetamide

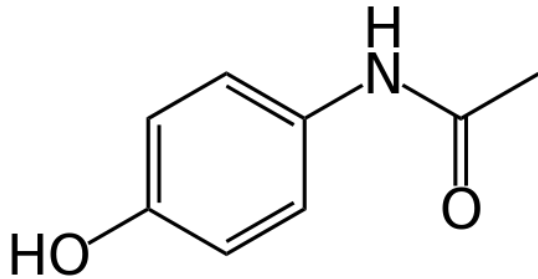

INN

paracetamol

Other names

Acetaminophen, panadol, tylenol, ...

RZVAJINKPMORJF-UHFFFAOYSA-N

# ■ Access only with the PATENTSCOPE account

The screenshot shows the WIPO PATENTSCOPE website. At the top left is the WIPO logo. To its right, the text 'PATENTSCOPE' is displayed, followed by the tagline 'Search International and National Patent Collections'. A horizontal navigation bar contains the following items: 'Search', 'Browse', 'Translate', 'Options', 'News', 'Login' (circled in red), and 'Help'. Below the navigation bar, the breadcrumb path 'Home > IP Services > PATENTSCOPE' is visible. The main content area is titled 'Simple Search' and contains the text: 'Using PATENTSCOPE you can search 58 million patent documents including 3 million published international patent applications (PCT). Detailed coverage information can be found here (->)'. Below this text is a search input field with a dropdown menu set to 'Front Page' and a 'Search' button. To the right of the input field, the text 'Office: All' is displayed. At the bottom of the page, a notification box states: 'PCT Publication 36/2016 (2016/09/09) is now available. The next publication date is scheduled as follows: Gazette number 37/2016 (2016/09/15). More'.

# How does it work?



PATENTSCOPE

Mobile | Deutsch | Español | Français | 日本語 | 한국어 | Português | Русский | 中文 | العربية |

Search International and National Patent Collections

WORLD INTELLECTUAL PROPERTY ORGANIZATION

Search Browse Translate Options News User: info@infochem.de Help

- Simple
- Advanced Search
- Field Combination
- Cross Lingual Expansion
- Chemical compounds

Front Page

Office: All

Search

PCT Publication 36/2016 (2016/09/09) is now available. The next publication date is scheduled as follows: Gazette number 37/2016 (2016/09/15). [More](#)

# How does it work?



PATENTSCOPE

Mobile | Deutsch | Español | Français | 日本語 | 한국어 | Português | Русский | 中文 |

Search International and National Patent Collections

WORLD INTELLECTUAL PROPERTY ORGANIZATION

Search

Browse

Translate

Options

News

Login

Help

Home > IP Services > PATENTSCOPE

Chemical Compounds

Structure editor

Convert structure

Load structure

Search For:

compound name

Type an accepted name, commercial name, CAS name, IUPAC name

Search for scaffold:

Office: All [Specify](#) ⇌

Search

Show in editor

Reset

Tooltip Help



# Example 1: Theobromine

- Its chemical formula is  $C_7H_8N_4O_2$  and IUPAC name: 3,7-dimethyl-1 *H*-purine-2,6-dione
- Theobromine is found in the seeds of the plant *Theobroma Cacao*, which is the well-known source of chocolate and cocoa. It has a bitter flavor, which gives dark chocolate its typical bitter taste.



## PATENTSCOPE

[Mobile](#) | [Deutsch](#) | [Español](#) | [Français](#) | [日本語](#) | [한국어](#) | [Português](#) | [Русский](#) | [中文](#) | [العربية](#) |

Search International and National Patent Collections

WORLD INTELLECTUAL PROPERTY ORGANIZATION

[Search](#)

[Browse](#)

[Translate](#)

[Options](#)

[News](#)

User: [info@infochem.de](#)

[Help](#)

[Home](#) > [IP Services](#) > PATENTSCOPE

### Chemical compounds search

[\[Help\]](#)

[Structure editor](#)

**[Convert structure](#)**

[Upload structure](#)

Compound name



Theobromine

[Search](#)

[Show in editor](#)

[Reset](#)

Search for scaffold:

Office:

[All](#)

[Specify](#) ⇌

Tooltip Help

Structure editor   Convert structure   Upload structure

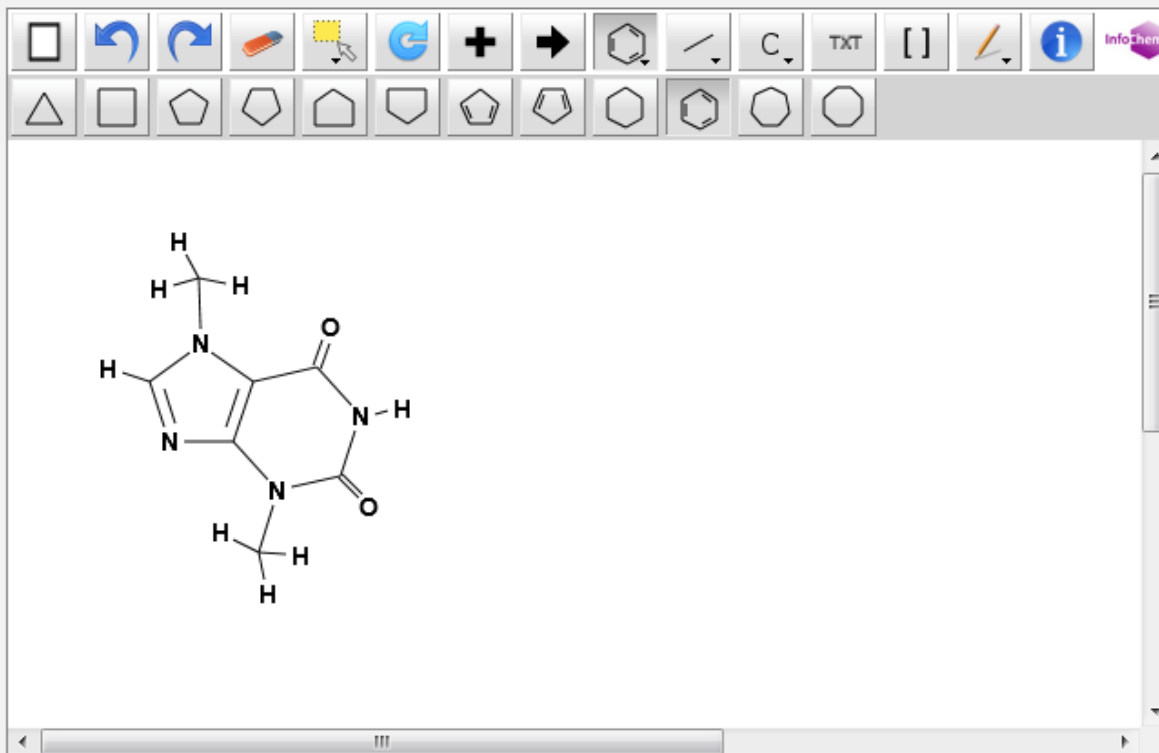

InChI: InChI=1S/C7H8N4O2/c1-10-3-8-5-4(10)6(12)9-7(13)11(5)2/h3H,1-2H3,(H,9,12,13)  
InChIKey: YAPQBXQYLJRXSA-UHFFFAOYSA-N  
Molecular Formula: C7H8N4O2  
Molecular Weight: 180.167 g/mol

Search

Reset

Search for scaffold:

Office: All [Specify ⇌](#)

Tooltip Help

Results 1-10 of 5,978 for Criteria:CHEM:(YAPQBXQYLJRXSA-UHFFFAOYSA-N) Office(s):all Language:EN Stemming: true



prev

1

2

3

4

5

6

7

8

9

10

next

Page: 1 / 598 Go >

Refine Search

CHEM:(YAPQBXQYLJRXSA-UHFFFAOYSA-N)

Search



## Analysis

Sort by: Pub Date Desc

View

All

List Length 10

Machine translation

Int.Class	Appl.No	Title	Applicant	Ctr	PubDate
1. WO/2016/141458		<b>BISPHENOL ETHER DERIVATIVES AND METHODS FOR USING THE SAME</b>		WO	15.09.2016
C07C 69/21	PCT/CA2016/000070		BRITISH COLUMBIA CANCER AGENCY BRANCH		ANDERSEN, Raymond John
Compounds having a structure of Formula I, or a pharmaceutically acceptable salt, tautomer or stereoisomer thereof, wherein R1, R2, L1, L2, L3, X, a, b, c, n, and m are as defined herein, are provided. Uses of such compounds for modulating androgen receptor activity and uses as therapeutics as well as methods for treatment of subjects in need thereof, including prostate cancer are also provided.					
2. WO/2016/142250		<b>BENZAZEPINE DICARBOXAMIDE COMPOUNDS</b>		WO	15.09.2016
C07D 403/12	PCT/EP2016/054487		F. HOFFMANN-LA ROCHE AG		HOVES, Sabine
This invention relates to novel benzazepine dicarboxamide compounds of the formula (I), wherein R1 to R4 are as defined in the description and in the claims, as well as pharmaceutically acceptable salts thereof. These compounds are TLR agonists and may therefore be useful as medicaments for the treatment of diseases such as cancer, autoimmune diseases, inflammation, sepsis, allergy, asthma, graft rejection, graft-versus-host disease, immunodeficiencies, and infectious diseases.					
3. WO/2016/142310		<b>TRICYCLIC DLK INHIBITORS AND USES THEREOF</b>		WO	15.09.2016
C07D 491/14	PCT/EP2016/054725		F. HOFFMANN-LA ROCHE AG		ESTRADA, Anthony
The invention relates to compounds of formula (I) and salts thereof, wherein ring A and R1-R2 have any of the values defined in the specification. The compounds and salts are useful for treating DLK mediated disorders. The invention also provides pharmaceutical compositions comprising a compound of formula (I), or a pharmaceutically acceptable salt thereof, as well as methods of using said compounds, salts, or compositions as DLK inhibitors and for treating neurodegeneration diseases and disorders.					

## 1. (WO2016141458) BISPHENOL ETHER DERIVATIVES AND METHODS FOR USING THE SAME

PCT Biblio. Data Description Claims National Phase Notices **Compounds** Drawings Documents

Latest bibliographic data on file with the International Bureau [Submit observation](#)

PermaLink 

Pub. No.: WO/2016/141458 International Application No.: PCT/CA2016/000070

Publication Date: 15.09.2016 International Filing Date: 11.03.2016

IPC: C07C 69/21 (2006.01), A61K 31/05 (2006.01), A61P 35/00 (2006.01), C07C 43/23 (2006.01), C07F 9/40 (2006.01) 

Applicants: BRITISH COLUMBIA CANCER AGENCY BRANCH [CA/CA]; 600 West 10th Avenue Vancouver, British Columbia V5Z 4E6 (CA).  
THE UNIVERSITY OF BRITISH COLUMBIA [CA/CA]; University-Industry Liaison Office #103-6190 Agronomy Road Vancouver, British Columbia V6T 1ZE (CA)

Inventors: ANDERSEN, Raymond John; (CA).  
JIAN, Kunzhong; (CA).  
SADAR, Marianne Dorothy; (CA).  
MAWJI, Nasrin R.; (CA).  
BANUELOS, Carmen Adriana; (CA)

Agent: DEETH WILLIAMS WALL LLP; 150 York Street, Suite 400 Toronto, Ontario M5H 3S5 (CA)

Priority Data: 62/131,969 12.03.2015 US

Title (EN) BISPHENOL ETHER DERIVATIVES AND METHODS FOR USING THE SAME  
(FR) DÉRIVÉS D'ÉTHÉR DE BISPHÉNOL ET LEURS PROCÉDÉS D'UTILISATION

Abstract: (EN) Compounds having a structure of Formula I, or a pharmaceutically acceptable salt, tautomer or stereoisomer thereof, wherein R<sup>1</sup>, R<sup>2</sup>, L<sup>1</sup>, L<sup>2</sup>, L<sup>3</sup>, X, a, b, c, n, and m are as defined herein, are provided. Uses of such compounds for modulating androgen receptor activity and uses as therapeutics as well as methods for treatment of subjects in need thereof, including prostate cancer are also provided.  
(FR) Cette invention concerne des composés ayant une structure de formule I : ou un sel, un tautomère ou un stéréoisomère pharmaceutiquement acceptable de ceux-ci, où R<sup>1</sup>, R<sup>2</sup>, L<sup>1</sup>, L<sup>2</sup>, L<sup>3</sup>, X, a, b, c, n et m étant tels que définis dans la présente. L'invention concerne également les utilisations de ces composés pour moduler l'activité du récepteur des androgènes et leurs utilisations comme substances thérapeutiques, ainsi que des méthodes destinées à traiter des sujets en ayant besoin, dont des sujets atteints de cancer de la prostate.

Designated States: AE, AG, AL, AM, AO, AT, AU, AZ, BA, BB, BG, BH, BN, BR, BW, BY, BZ, CA, CH, CL, CN, CO, CR, CU, CZ, DE, DK, DM, DO, DZ, EC, EE, EG, ES, FI, GB, GD, GE, GH, GM, GT, HN, HR, HU, ID, IL, IN, IR, IS, JP, KE, KG, KN, KP, KR, KZ, LA, LC, LK, LR, LS, LU, LY, MA, MD, ME, MG, MK, MN, MW, MX, MY, MZ, NA, NG, NI, NO, NZ, OM, PA, PE, PG, PH, PL, PT, QA, RO, RS, RU, RW, SA, SC, SD, SE, SG, SK, SL, SM, ST, SV, SY, TH, TJ, TM, TN, TR, TT, TZ, UA, UG, US, UZ, VC, VN, ZA, ZM, ZW.  
African Regional Intellectual Property Organization (BW, GH, GM, KE, LR, LS, MW, MZ, NA, RW, SD, SL, ST, SZ, TZ, UG, ZM, ZW)  
Eurasian Patent Organization (AM, AZ, BY, KG, KZ, RU, TJ, TM)  
European Patent Office (AL, AT, BE, BG, CH, CY, CZ, DE, DK, EE, ES, FI, FR, GB, GR, HR, HU, IE, IS, IT, LT, LU, LV, MC, MK, MT, NL, NO, PL, PT, RO, RS, SE, SI, SK, SM, TR)

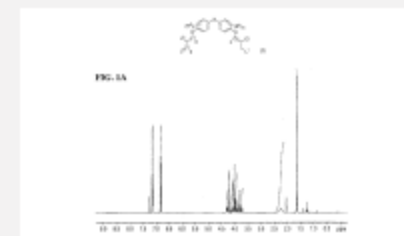

1. (WO2016141458) BISPHENOL ETHER DERIVATIVES AND METHODS FOR USING THE SAME

PCT Biblio. Data Description Claims National Phase Notices Compounds Drawings Documents

Title Abstract Description Claims

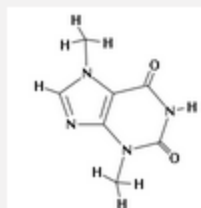

Theobromine

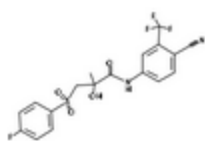
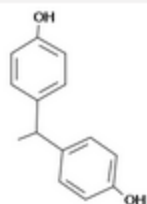

Bicalutamide

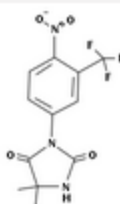

Nilutamide

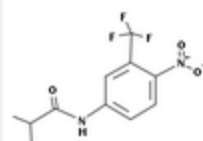

Flutamide

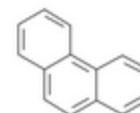
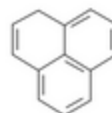
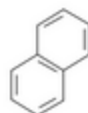
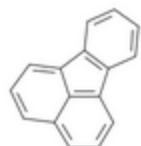
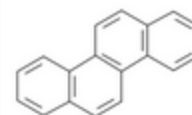
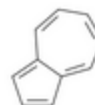
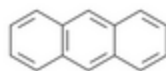
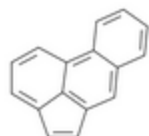
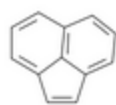
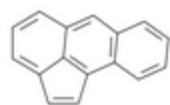
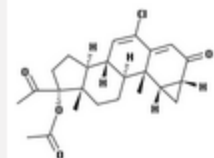
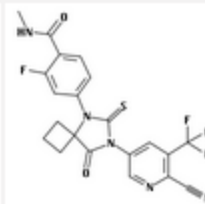

Compounds as described herein may be in the free form or in the form of a salt thereof. In some embodiments, compounds as described herein may be in the form of a pharmaceutically acceptable salt, which are known in the art (Berge et al., J. Pharm. Sci. 1977, 66, 1). Pharmaceutically acceptable salt as used herein includes, for example, salts that have the desired pharmacological activity of the parent compound (salts which retain the biological effectiveness and/or properties of the parent compound and which are not biologically and/or otherwise undesirable). Compounds as described herein having one or more functional groups capable of forming a salt may be, for example, formed as a pharmaceutically acceptable salt. Compounds containing one or more basic functional groups may be capable of forming a pharmaceutically acceptable salt. Pharmaceutically acceptable salts may be derived from benzoic acid, benzenesulfonic acid, butyric acid, cinnamic acid, digluconic acid, dodecylsulfonic acid, ethanesulfonic acid, hemisulfonic acid, heptanoic acid, hexanoic acid, hydrochloric acid, malic acid, maleic acid, malonic acid, mandelic acid, nitric acid, oxalic acid, pantoic acid, pectic acid, pyruvic acid, salicylic acid, succinic acid, sulfuric acid, and other acids. Functional groups may be capable of forming pharmaceutically acceptable salts with inorganic bases based on alkaline metals or alkaline earth metals, organic bases based on primary and secondary amine compounds, quaternary amine compounds, sulfonium compounds, phosphonium compounds, pyridinium compounds, and other bases. Pharmaceutically acceptable salts may be derived from a pharmaceutically acceptable metal cation such as ammonium, sodium, potassium, lithium, calcium, magnesium, iron, zinc, copper, manganese, aluminum, and other metals. Pharmaceutically acceptable salts may also be derived from ammonium, sodium, potassium, lithium, calcium, magnesium, iron, zinc, copper, manganese, aluminum, and other metals. Pharmaceutically acceptable salts may also be derived from ammonium, sodium, potassium, lithium, calcium, magnesium, iron, zinc, copper, manganese, aluminum, and other metals.

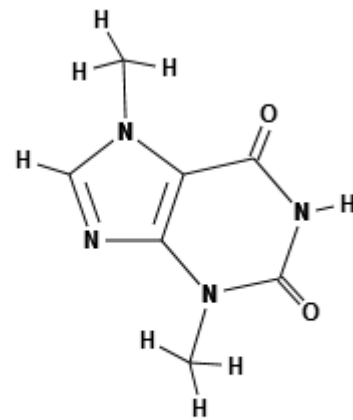

Theobromine

sodium, potassium, lithium, calcium, magnesium, iron, zinc, copper, manganese, aluminum, and other metals. Pharmaceutically acceptable salts may also be derived from ammonium, sodium, potassium, lithium, calcium, magnesium, iron, zinc, copper, manganese, aluminum, and other metals. Pharmaceutically acceptable salts may also be derived from ammonium, sodium, potassium, lithium, calcium, magnesium, iron, zinc, copper, manganese, aluminum, and other metals. Pharmaceutically acceptable salts may also be derived from ammonium, sodium, potassium, lithium, calcium, magnesium, iron, zinc, copper, manganese, aluminum, and other metals.

In some embodiments, compounds and all different forms thereof (e.g. free forms, salts, polymorphs, isomeric forms) as described herein may be in the solvent addition form, for example, solvates. Solvates contain either stoichiometric or non-stoichiometric amounts of a solvent in physical association with the compound or salt thereof. The solvent may be, for example, and without limitation, a pharmaceutically acceptable solvent. For example, hydrates are formed when the solvent is water or alcoholates are formed when the solvent is an alcohol.

In some embodiments, compounds and all different forms thereof (e.g. free forms, salts, solvates, isomeric forms) as described herein may include crystalline and amorphous forms, for example, polymorphs, pseudopolymorphs, conformational polymorphs, amorphous forms, or a combination thereof. Polymorphs include different crystal packing arrangements of the same elemental composition of a compound. Polymorphs usually have different X-ray diffraction patterns, infrared spectra, melting points, density, hardness, crystal shape, optical and electrical properties, stability and/or solubility. Those skilled in the art will appreciate that various factors including recrystallization solvent, rate of crystallization and storage temperature may cause a single crystal form to dominate.

In some embodiments, compounds and all different forms thereof (e.g. free forms, salts, solvates, polymorphs) as described herein include isomers such as geometrical isomers, optical isomers based on asymmetric carbon, stereoisomers, tautomers, individual enantiomers, individual diastereomers, racemates, diastereomeric mixtures and combinations thereof, and are not limited by the description of the formula illustrated for the sake of convenience.

### III. Methods

The present compounds find use in any number of methods. For example, in some embodiments the compounds can be useful in methods for modulating

pharmaceutically acceptable organic or inorganic acid. Pharmaceutically acceptable acids include, for example, acetic acid, adipic acid, alginate, aspartic acid, ascorbic acid, benzoic acid, camphorsulfonic acid, cyclopentanepropionic acid, diethylacetic acid, heptanoic acid, gluconic acid, glycerophosphoric acid, glycolic acid, hydrochloric acid, hydroiodic acid, 2-hydroxyethanesulfonic acid, isomotic acid, lactic acid, maleic acid, malic acid, malonic acid, mandelic acid, nitric acid, oxalic acid, pantoic acid, pectic acid, pyruvic acid, salicylic acid, succinic acid, sulfuric acid, and other acids. Functional groups may be capable of forming pharmaceutically acceptable salts with inorganic bases based on alkaline metals or alkaline earth metals, organic bases based on primary and secondary amine compounds, quaternary amine compounds, sulfonium compounds, phosphonium compounds, pyridinium compounds, and other bases. Pharmaceutically acceptable salts may be derived from a pharmaceutically acceptable metal cation such as ammonium, sodium, potassium, lithium, calcium, magnesium, iron, zinc, copper, manganese, aluminum, and other metals. Pharmaceutically acceptable salts may also be derived from ammonium, sodium, potassium, lithium, calcium, magnesium, iron, zinc, copper, manganese, aluminum, and other metals. Pharmaceutically acceptable salts may also be derived from ammonium, sodium, potassium, lithium, calcium, magnesium, iron, zinc, copper, manganese, aluminum, and other metals.

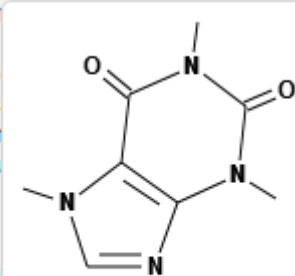

num, ammonium, sodium, potassium, lithium, calcium, magnesium, iron, zinc, copper, manganese, aluminum, and other metals. Pharmaceutically acceptable salts may also be derived from ammonium, sodium, potassium, lithium, calcium, magnesium, iron, zinc, copper, manganese, aluminum, and other metals. Pharmaceutically acceptable salts may also be derived from ammonium, sodium, potassium, lithium, calcium, magnesium, iron, zinc, copper, manganese, aluminum, and other metals. Pharmaceutically acceptable salts may also be derived from ammonium, sodium, potassium, lithium, calcium, magnesium, iron, zinc, copper, manganese, aluminum, and other metals.

# Combine chemical search criteria



PATENTSCOPE

Mobile | Deutsch | Español | Français | 日本語 | 한국어 | Português | Русский | 中文 | العربية |

Search International and National Patent Collections

WORLD INTELLECTUAL PROPERTY ORGANIZATION

Search

Browse

Translate

Options

News

User: info@infochem.de

Help

Home > IP Services > PATENTSCOPE

Results 1-10 of 9 for Criteria:(CTR:WO AND CHEM:(YAPQBXQYLJRXSA-UHFFFAOYSA-N)) AND EN\_AB:chocolate Office(s):wo Language:All   
Stemming: true

prev 1 next Page: 1 / 1 [Go >](#)

Refine Search (CTR:WO AND CHEM:(YAPQBXQYLJRXSA-UHFFFAOYSA-N)) AND EN\_AB:chocolate



Search

RSS



## Analysis

Sort by: Pub Date Asc  View All  List Length 10  [Machine translation](#)

Int.Class	Appl.No	Title	Applicant	Ctr	PubDate
1. WO/2002/074321		COMPOSITION COMPRISING COCOA AND A DOPAMINE D2 RECEPTOR AGONIST		WO	26.09.2002
A23L 1/30	 PCT/NL2002/000184	N.V. NUTRICIA		TER LAAK, Wies	
The invention pertains to a composition and a method for the treatment of mood disorders, in particular of treating, preventing or alleviating depression, mood disorders or insufficient mood, obesity, overweight, premenstrual syndrome, craving, carbohydrate craving, chocolate craving, menopausal complaints, erectile dysfunction and/or reduced libido. The composition contains cocoa or one or more if its pharmacologically active components, and a dopamine D2 receptor agonist.					
2. WO/2002/078746		NOVEL CHOCOLATE COMPOSITION AS DELIVERY SYSTEM FOR NUTRIENTS AND MEDICATIONS		WO	10.10.2002
A23G 1/00	 PCT/US2002/009597	ALTAFFER, Paulo		HUGHES, Kerry	

A novel chocolate product for use in delivering medicaments and/or nutrients to animals, particularly humans, specially formulated so that the craving for such product by animals, particularly humans, is significantly greater than the craving for chocolate conventionally used in pharmaceutical compositions and the concentration, optimization, and the addition of endogenous and exogenous ingredients to increase such craving as well as to treat specific indications. The chocolate product contains: from about 0.5 to about 200 milligrams, more preferably from about 5 to about 20 milligrams, of one or more biogenic amines per 1 gram of the chocolate product; from about 10 to about 500 milligrams, more preferably from about 20 to about 200 milligrams, of one or more amino acids per 1 gram of the chocolate product; from about 1 micrometer to about 20 milligrams, more preferably from about 10 micrometers to about 10 milligrams, of one or more



# International Non proprietary Names

## WIKIPEDIA:

- INNs are official generic and non proprietary names given to a pharmaceutical drug or active ingredients issued by the World Health Organization (WHO).
- Growing need to be able to search INNs in patent texts
- PATENTSCOPE supports the search of 6917 INNs by Inchikey

# Example 2: ritonavir

Chemical compounds search [Help]

Structure editor Convert structure Upload structure

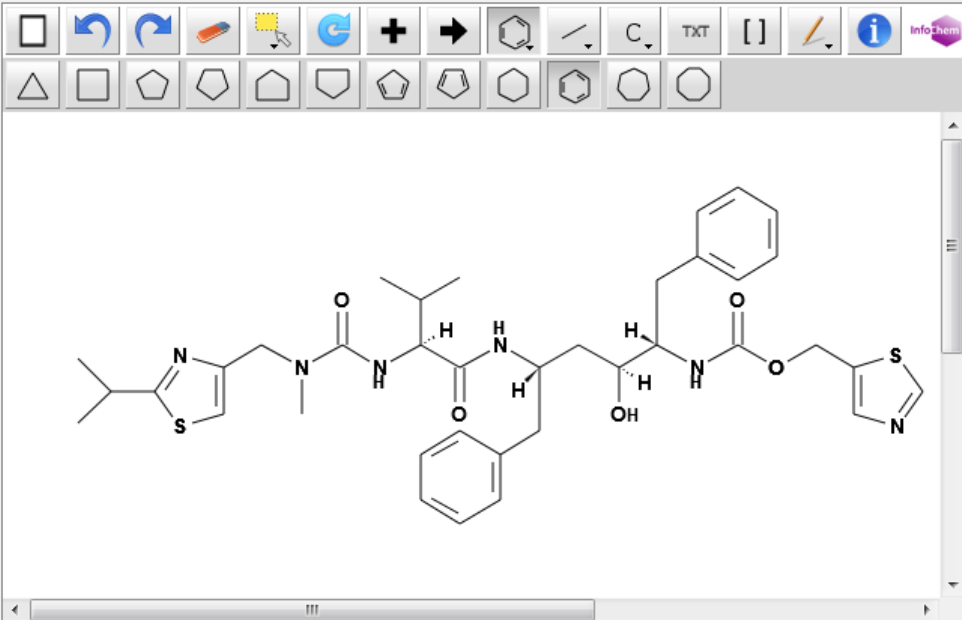

**InChI:** InChI=1S/C37H48N6O5S2  
/c1-24(2)33(42-36(46)43(5)20-29-22-49-35(40-29)25(3)4)34(45)39-28(16-26-12-8-6-9-13-26)18-32(44)31(17-27-14-10-7-11-15-27)41-37(47)48-21-30-19-38-23-50-30  
/h6-15,19,22-25,28,31-33,44H,16-18,20-21H2,1-5H3,(H,39,45)(H,41,47)(H,42,46)/t28-,31-,32-,33-/m0/s1

**InChIKey:** NCDNCNXCDXHOMX-XGKFQTDJSA-N

**Molecular Formula:** C37H48N6O5S2

**Molecular Weight:** 720.9572 g/mol

**Weight:**

Search Reset

Results 1-10 of 5,738 for [Criteria](#):CTR:WO AND CHEM:(NCDNCNXCDXHOMX-XGKFQTDJSA-N) [Office\(s\)](#):wo [Language](#):All [Stemming](#):true[prev](#)[1](#)[2](#)[3](#)[4](#)[5](#)[6](#)[7](#)[8](#)[9](#)[10](#)[next](#)Page:  / 574 [Go >](#)Refine Search [Search](#)

## Analysis

Sort by: View List Length [Machine translation](#)

Int.Class	Appl.No	Title	Applicant	Ctr	PubDate
1. WO/1994/014436		RETROVIRAL PROTEASE INHIBITING COMPOUNDS		WO	07.07.1994
A61K 31/425	PCT/US1993/012326	ABBOTT LABORATORIES		KEMPF, Dale, J.	
A retroviral protease inhibiting compound of formula (A) is disclosed.					
2. WO/1995/007696		PHARMACEUTICAL COMPOSITION OF HIV-PROTEASE INHIBITORS		WO	23.03.1995
A61K 9/48	PCT/US1994/009788	ABBOTT LABORATORIES		AL-RAZZAK, Laman, A.	
A pharmaceutical composition is disclosed which comprises a solution of an HIV protease inhibiting compound in a pharmaceutically acceptable organic solvent comprising a pharmaceutically acceptable alcohol. The composition can optionally comprise a pharmaceutically acceptable acid or a combination of pharmaceutically acceptable acids. The solution can optionally be encapsulated in hard gelating capsule or soft elastic gelating capsules. The solution can optionally be granulated with a pharmaceutically acceptable granulating agent.					
3. WO/1995/009614		PHARMACEUTICAL COMPOSITION		WO	13.04.1995
A61K 9/14	PCT/US1994/010096	ABBOTT LABORATORIES		AL-RAZZAK, Laman, A.	

A solid pharmaceutical composition is disclosed which comprises a pharmaceutically acceptable adsorbent or a mixture of pharmaceutically acceptable adsorbents to which is adsorbed a mixture of (1) a pharmaceutically acceptable organic solvent or a mixture of pharmaceutically acceptable organic solvents, (2) an HIV protease inhibiting compound and (3) one or more pharmaceutically acceptable acids. The solid composition can optionally be encapsulated in a hard gelatin capsule.

8. (2S,3S,5S)-5-(N-(N-((N-Methyl-N-((2-isopropyl-4-thiazolyl)methyl)-amino)carbonyl)valinyl)amino)-2-(N-((5-thiazolyl)methoxycarbonyl)amino)-1,6-diphenyl-3-hydroxyhexane; or a pharmaceutically acceptable salt, ester or prodrug thereof.

9. (2S,3S,5S)-5-(N-(N-((N-Methyl-N-((2-isopropyl-4-oxazolyl)methyl)-amino)carbonyl)valinyl)amino)-2-(N-((5-oxazolyl)methoxycarbonyl)amino)-1,6-diphenyl-3-hydroxyhexane; or a pharmaceutically acceptable salt

10. A compound selected from the group consisting of:  
 2-(N-((5-thiazolyl)methoxycarbonyl)amino)-1,6-diphenyl-3-hydroxyhexane;  
 (2S,3S,5S)-5-(N-(N-((2-Isopropyl-4-thiazolyl)methoxycarbonyl)amino)-2-(N-((2-Isopropyl-4-thiazolyl)methoxycarbonyl)amino)-1,6-diphenyl-3-hydroxyhexane;  
 (2S,3S,5S)-5-(N-(N-((2-Isopropyl-4-thiazolyl)methoxycarbonyl)amino)-2-(N-((2-(N,N-Dimethylamino)-4-thiazolyl)methoxycarbonyl)amino)-1,6-diphenyl-3-hydroxyhexane;  
 (2S,3S,5S)-5-(N-(N-((2-(N,N-Dimethylamino)-4-thiazolyl)methoxycarbonyl)amino)-2-(N-((2-(N,N-Dimethylamino)-4-thiazolyl)methoxycarbonyl)amino)-1,6-diphenyl-3-hydroxyhexane;  
 (2S,3S,5S)-5-(N-(N-((2-(4-Morpholinyl)-4-thiazolyl)methoxycarbonyl)amino)-2-(N-((2-(4-Morpholinyl)-4-thiazolyl)methoxycarbonyl)amino)-1,6-diphenyl-3-hydroxyhexane;  
 (2S,3S,5S)-5-(N-(N-((2-(1-Pyrrolidinyl)-4-thiazolyl)methoxycarbonyl)amino)-2-(N-((2-(1-Pyrrolidinyl)-4-thiazolyl)methoxycarbonyl)amino)-1,6-diphenyl-3-hydroxyhexane;

(2S,3S,5S)-5-(N-(N-((N-Methyl-N-((2-isopropyl-4-oxazolyl)methyl)-amino)carbonyl)valinyl)amino)-2-(N-((5-oxazolyl)methoxycarbonyl)amino)-1,6-diphenyl-3-hydroxyhexane;  
 (2S,3S,5S)-5-(N-(N-((N-Methyl-N-((2-isopropyl-4-thiazolyl)methyl)-amino)carbonyl)valinyl)amino)-2-(N-((5-thiazolyl)methoxycarbonyl)amino)-1,6-diphenyl-3-hydroxyhexane;  
 (2S,3S,5S)-5-(N-(N-((N-Methyl-N-((2-isopropyl-4-thiazolyl)methyl)-amino)carbonyl)valinyl)amino)-2-(N-((5-thiazolyl)methoxycarbonyl)amino)-1,6-diphenyl-3-hydroxyhexane; and  
 (2S,3S,5S)-5-(N-(N-((N-Methyl-N-((2-isopropyl-4-oxazolyl)methyl)-amino)carbonyl)valinyl)amino)-2-(N-((5-oxazolyl)methoxycarbonyl)amino)-1,6-diphenyl-3-hydroxyhexane; or a pharmaceutically acceptable salt, ester or prodrug thereof.

11. A compound of the formula:

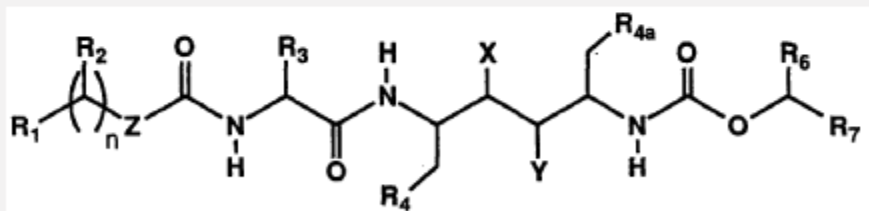

wherein R<sub>1</sub> is monosubstituted thiazolyl, monosubstituted oxazolyl, monosubstituted isoxazolyl or monosubstituted isothiazolyl wherein the substituent is selected from (i) loweralkyl, (ii) loweralkenyl, (iii) cycloalkyl, (iv) cycloalkylalkyl, (v) cycloalkenyl, (vi) cycloalkenylalkyl, (vii) heterocyclic wherein the heterocyclic is selected from aziridinyl, azetidiny, pyrrolidinyl, piperidinyl, piperazinyl, morpholinyl, thiomorpholinyl, thiazolyl, oxazolyl, isoxazolyl, isothiazolyl, pyridinyl, pyrimidinyl, pyridazinyl and pyrazinyl and wherein the heterocyclic is unsubstituted or substituted with a substituent selected from halo, loweralkyl, hydroxy, alkoxy and thioalkoxy, (viii) (heterocyclic)alkyl wherein heterocyclic is defined as above, (ix) alkoxyalkyl, (x) thioalkoxyalkyl, (xi) alkylamino, (xii) dialkylamino, (xiii) phenyl wherein the phenyl ring is unsubstituted or substituted with a substituent selected from halo, loweralkyl, hydroxy, alkoxy and thioalkoxy, (xiv) phenylalkyl wherein the phenyl ring is unsubstituted or substituted as defined above, (xv) dialkylaminoalkyl, (xvi) alkoxy and (xvii) thioalkoxy;

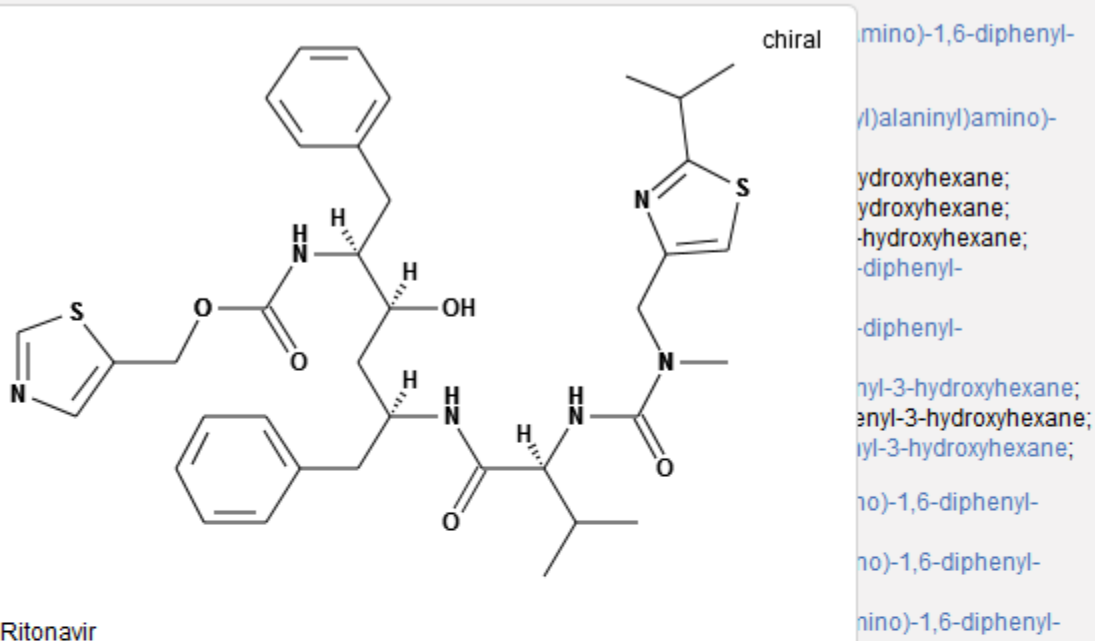

# Scope

- Works on **developed complete exact formulas** ≠ Markush structures (-R) that are chemical symbols used to indicate a collection of chemicals with similar structures.

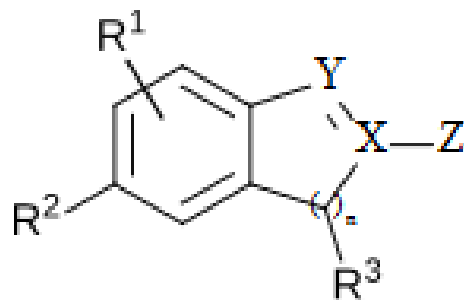

- Chemical elements, short names (less than 4 characters), common solvents and polymers are not annotated by design
- PCT and US national collections with IPC codes related to chemistry
- Languages: English and German

# Warning

- Based on state of the art fully automated chemical recognition algorithms: the technology is NOT 100% accurate
- OCR errors in the available patent full texts make the recognition of chemical compound even more challenging
- => Use it as a discovery tool knowing that the results are not exhaustive, nor all exact (precision, recall)

# New video tutorials

<https://patentscope.wipo.int/search/en/tutorial.jsf>

## Presentation

What is PATENTSCOPE, what is included in its database and how to access it?

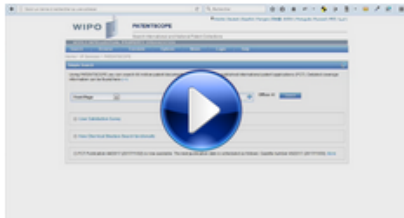

## Search by keyword, number, inventor/company name

How to find patent documents using simple keywords, numbers, dates etc.

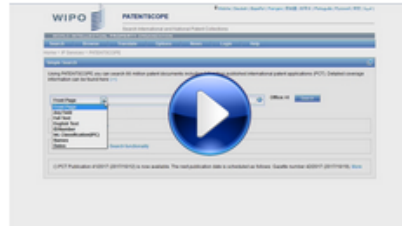

## Complex queries with predefined search fields

How to use and combine many predefined fields to build more complex queries

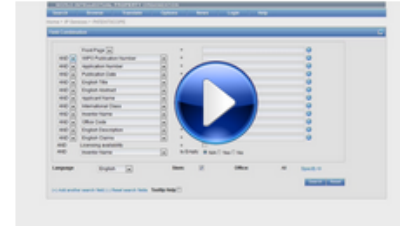

## Complex queries

How to combine search fields, operators and search criterias to build complex queries from scratch



## Chemical information search

How to search for chemical information

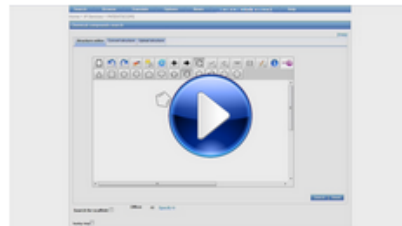

## Extend your queries by adding synonyms and translations

How to use CLIR to add synonyms and their translations to your query in order to search in collections disclosed in a foreign language

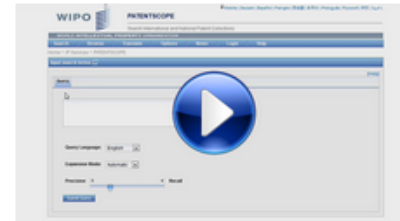

# PATENTSCOPE what's next?

Future Coverage:

- IT, NZ, RO, GE, NL,...

Future functionality:

- Search of chemical compounds for the collections of EP, CN, JP, KR and RU
- Search of substructures for chemical compounds



# Monthly webinar



## PATENTSCOPE Webinars

Webinars are used by WIPO to deliver information, training and updates on the [PATENTSCOPE search system](#) to a remote audience using the Internet.

Please [contact us](#) if your firm, company or organization is interested in attending a webinar on a particular topic.

### Quick links

- [Frequently asked questions](#)

# GLOBAL DATABASES, TOOLS, AND PLATFORMS FOR IP BUSINESS (FREE)

- PATENTSCOPE



- Global Brand Database

- Global Design Database

- WIPO Lex

- WIPO Pearl

# GLOBAL BRAND DATABASE

- Over 34 million records relating to internationally-protected trademarks, etc.
- Goal is to include all brand-related information from all sources
- Currently searches across multiple collections, including:
  - Trademarks registered under Madrid System
  - Appellations of Origin registered under Lisbon System
  - Emblems protected under the Paris Convention 6ter
  - National trademark collections of 38 countries – with more coming soon

# Global Brand Database

Video demo:

[http://www.wipo.int/pressroom/en/articles/2014/article\\_0007.html](http://www.wipo.int/pressroom/en/articles/2014/article_0007.html)

# Global Brand Database

Perform a trademark search by text or image in brand data from multiple national and international sources, including trademarks, appellations of origin and official emblems.

<b>Data from Papua New Guinea</b> 2016-02-16 available Over 23,000 records added	<b>Reports with images</b> 2016-01-21 PDF and HTML reports now include embedded images	<b>Data from the Republic of Korea</b> 2015-11-20 available Over 3,000,000 records added	<b>Moldovan data available</b> 2015-11-10 Over 35,000 records added	<b>Germa NEWS</b> 2015-11-10 Over 1,800,000 records added
--	--	--	--	--

## SEARCH BY

Brand | Names | Numbers | Dates | Class | Country

Text =

Image Class =

Goods (All) ▾ =

search 🔍

## FILTER BY

Source | Image | Status | Origin | App. Date \* | Expiration \* |

AE TM	39,540	AU TM	1,503,884	BN TM	38,002
CA TM	1,448,752	CH TM	367,508	DE TM	1,848,197
DK TM	282,649	DZ TM	26,187	EE TM	56,027
EG TM	75,567	EM TM	1,311,719	ID TM	755,527
IL TM	249,914	LA TM	37,031	JP TM	1,877,512
KH TM	69,078	KR TM	3,083,609	MA TM	135,386

Display: List ▾ Sort: Value - asc ▾

filter 🔽

1 - 30 / 25,047,218

TMview

Display: 30 ▾ per page options ⚙

1 / 834,908

	Brand	Source	Status	Score	Origin	Holder	Number	App. Date	Image Class	Nice Class	Image
<input type="checkbox"/>	Arrowsmith	NZ TM	Pending	1	NZ	ARROWSMITH BRANDS LIMITED	1040442	2016-04-04	VC.24.15, VC.26.03	45	
<input type="checkbox"/>	BOSS	NZ TM	Pending	1	NZ	AUTOGROW SYSTEMS LIMITED	1040452	2016-04-04		9	
<input type="checkbox"/>	Raw Blends	NZ TM	Pending	1	NZ	NEW ZEALAND'S PATCH LIMITED	1040455	2016-04-04		39	
<input type="checkbox"/>	ONL	NZ TM	Pending	1	NZ	OCEANIA NATURAL LIMITED	1040449	2016-04-04		3, 5, 30, 32	
<input type="checkbox"/>	No Verbal Elements	NZ TM	Pending	1	NZ	Yun-Yi Wang	1040453	2016-04-04		3	
<input type="checkbox"/>	RIDEFAR Extra Virgin Coconut Oil	NZ TM	Pending	1	NZ	RIDEFAR LIMITED	1040445	2016-04-04	VC.05.07	29	
<input type="checkbox"/>	Kiwiadviser	NZ TM	Pending	1	NZ	Yevgen Bidnyy	1040447	2016-04-04		45	

# Global Brand Database – Features

- Single intuitive interface to search 30 data collections
- Image Search by example
- Interactive & dynamic search with immediate feedback
- Fuzzy, phonetic and word-stem matches
- Automatic term suggestion
- Easy search of US or Vienna image class
- Full Boolean, proximity and range options
- Unlimited, customizable results browsing
- Saved searches and record sets
- Instant, graphical data analysis

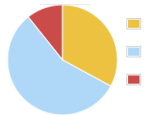
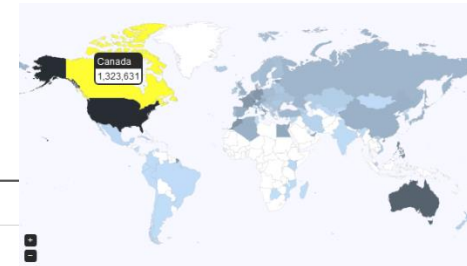
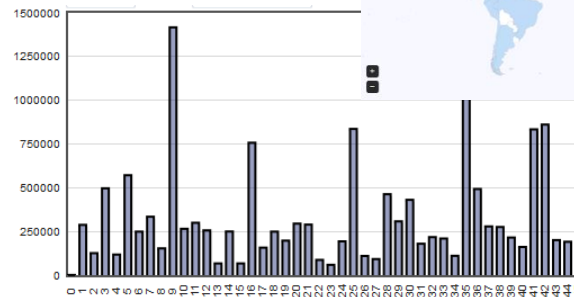
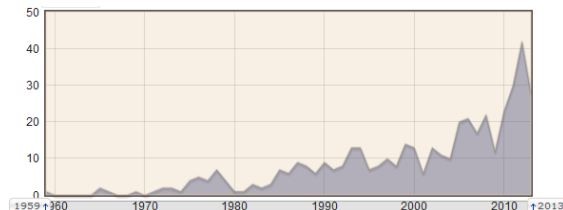

# IMAGE SEARCH

- Sort your results by their visual similarity to an image you provide
- World's first public trademark database to provide search by image
- Choose the search strategy best suited to your particular mark

Search For

Find (in top results – without Vienna Class)



# How it works – Looking for logos similar to ‘Arla’

NEWS

## SEARCH BY

Brand Names Numbers Dates Class Country

Text =

Image Class =

Goods (All) ▾ =

1 - 30 / 25,034,570

Sort by

- arla
- arlac
- arlacel
- arlatone
- arlamol
- arlasolve
- arlanc
- arlanxeo
- arlan
- arlam

## FILTER BY

Source	Image	Status	Origin	App. Date *	Expiration *
AE TM	39,540	AU TM	1,502,367	BN TM	38,002
CA TM	1,448,752	CH TM	367,273	DE TM	1,846,960
DK TM	282,597	DZ TM	26,187	EE TM	56,020
EG TM	75,567	EM TM	1,310,387	ID TM	755,518
IL TM	249,839	LA TM	37,007	JP TM	1,877,512
KH TM	69,073	KR TM	3,082,279	MA TM	135,386

Display:  Sort:

				ArtAndOnly	FASHION WITH A POSITIVE IMPACT	LOOK GOOD, FEEL GOOD, BE GOOD	ingenus Pharmaceuticals	FLAWA	
HIERBABUEN DELMEDIO MENTHA HEMINGWAY	KAROKA wellness	leadxpro	BIOTOOL	HN	BODUM	FARAWAVES	FIBERNOMICS	HACHENE	TOMAIL
BIONIC	COFFEE SOUL	MAXI BAZAR	Q FERMENTATIO	MET	BYSTRIC	almacasa SELBSTBESTI UMSORGT	MMS Pulse	LEADXPRO	medic jobs



# Global Brand Database

NEWS

Perform a trademark search by text or image in brand data from multiple national and international sources, including trademarks, appellations of origin and official emblems.

## SEARCH BY

Brand | Names | Numbers | Dates | Class | Country

Text =

Image Class =

Goods (All) ▾ =

search 🔍

CURRENT SEARCH

BRAND:arla ✕

## FILTER BY

Source | Image | Status | Origin | App. Date \* | Expiration \*

AE TM	4	AU TM	8	BN TM	0
CA TM	7	CH TM	1	DE TM	9
DK TM	63	DZ TM	0	EE TM	1
EG TM	10	EM TM	29	ID TM	11
IL TM	14	LA TM	4	JP TM	0
KH TM	4	KR TM	7	MA TM	0
MD TM	0	MX TM	11	NZ TM	5
OM TM	3	PG TM	0	PH TM	7
SG TM	24	TO TM	0	US TM	13

Display: List ▾ Sort: Value - asc ▾

filter ▾

31 - 60 / 251

TMview 🔗



Display: 30 ▾ per page

options ⚙

2 / 9

Sort by Origin - asc ▾



ARLA



ARLA



ARLA  
NATURA

ARLA  
WELLNESS



WO TM (Active)  
990596  
Arla  
2008-09-08 (DK)  
Arla Foods amba  
NC: 1, 5, 29, 30, 31, 32



ARLA  
PROTINO



ARLA  
MINI

31 - 60 / 251



Display: 30 ▾ per page

options ⚙

2 / 9

← back

(Information valid as of 2014-09-09)

## International Trademark



◀ 65 / 158 ▶

990596 - Arla

**(151) Date of the registration**

08.09.2008

**(180) Expected expiration date of the registration/renewal**

08.09.2018

**(270) Language(s) of the application**

English

**(732) Name and address of the holder of the registration**

Arla Foods amba  
Sønderhøj 14  
DK-8260 Viby J (DK)

**(813) Contracting State or Contracting Organization in the territory of which the holder has his domicile**

DK

**(740) Name and address of the representative**

Zacco Denmark A/S  
Hans Bekkevolds Allé 7  
DK-2900 Hellerup (DK)

**(540) Mark**



**(531) International Classification of the Figurative Elements of Marks (Vienna Classification)- VCL (6)**

**i** [05.05.20](#); [26.01.18](#); [29.01.13](#)

**(591) Information on colors claimed**

Dark green; Yellow; Stylized flowers

# Using Vienna Class – 05.05.20 (stylized flowers) and 26.01.18 (circles or ellipses containing one or more letters)

## SEARCH BY

Brand | Names | Numbers | Dates | Class | Country

Text =

Image Class =

Goods (All) ▾ =

search 🔍

### CURRENT SEARCH

IC:(05.05.20 AND 26.01.18) \*

## FILTER BY

Source | Image | Status | Origin | App. Date \* | Expiration \*

AE TM	0	AU TM	0	BN TM	0
CA TM	159	CH TM	0	DE TM	128
DK TM	0	DZ TM	17	EE TM	13
EG TM	2	EM TM	17	ID TM	0
IL TM	0	LA TM	2	JP TM	613
KH TM	48	KR TM	181	MA TM	0
MD TM	7	MX TM	159	NZ TM	45
OM TM	0	PG TM	0	PH TM	49
SG TM	0	TO TM	0	US TM	0

Display: List ▾ Sort: Value - asc ▾

filter ▾

1 - 30 / 1,484

TMview



Display: 30 ▾ per page options

1 / 50

Sort by Origin - asc ▾



1 - 30 / 1,484



Display: 30 ▾ per page options

1 / 50

# Using Image Search – drag image from results to image filter

**SEARCH BY** Brand Names Numbers Dates Class Country

Text =

Image Class =

Goods (All) ▾ =

**FILTER BY** Source Image Status Origin App. Date \* Expiration \*

Pick an image  or

Pick a strategy

Shape	Verbal	16
Color	Nonverbal	0
Texture	Combined	142
Composite	Unknown	19

Pick an image type

CURRENT SEARCH

31 - 60 / 251  Display: 30 per page  2 / 9

Sort by



31 - 60 / 251  Display: 30 per page  2 / 9

download report

Select a search strategy and, optionally, what type of image to look for and all images are sorted by similarity to your source image

Goods (All) =

search ↗

**FILTER BY**

Source Image Status Origin App. Date \* Expiration \*

Pick an image  delete

Pick a strategy

- Shape
- Color
- Texture
- Composite

Pick an image type

Verbal	0
Nonverbal	1,522,717
Combined	6,865,315
Unknown	0

filter ▼

CURRENT FILTER

IMAGE: Shape \* ITY: (Nonverbal Combined) \*

1 - 60 / 8,388,032

TMview ↗



Display: 60 per page

options ⌘



1

/ 139,801



Sort by Score - desc ▼



Combine with Vienna class – or any other terms or filters. The image filter will sort matching records accordingly.

Image Class =

Goods (All) ▾ =

CURRENT SEARCH

FILTER BY

Display:  Sort:

CURRENT FILTER

Sort by



# Global Brand Database what's next?

Future Coverage:

- IT,...

Future functionality:

- New semantic image similarity search algorithm using Machine Learning

# GLOBAL DATABASES, TOOLS, AND PLATFORMS FOR IP BUSINESS (FREE)

- PATENTSCOPE
- Global Brand Database
-  ■ Global Design Database
- WIPO Lex
- WIPO Pearl



# GLOBAL DESIGN DATABASE

- URL: <http://www.wipo.int/designdb>
- Launched on January, 9<sup>th</sup> 2015.
  
- Free of charge simultaneous design-related searches across multiple collections, including:
  - designs registered under the Hague System
  - national design collections of CA, ES, JP, NZ, US, ID
  - other national collections, including DE, KR and EM coming soon

# Global Design Database

A world-wide collection of industrial designs data; including WIPO Hague registrations and information from participating national offices.

## SEARCH BY

Design Names Numbers Dates Country

Indication of Products ▾ =

Design class ▾ =  >

Description ▾ =

search 🔍

## FILTER BY

Source Designation Locarno Class Reg. Date ✕

CA Designs	<b>153,343</b>	ES Designs	<b>93,809</b>
JP Designs	<b>479,755</b>	NZ Designs	<b>44,187</b>
US Designs	<b>483,493</b>	WO Designs	<b>41,016</b>

Display: List ▾ Sort: Value - asc ▾

filter 🔍

1 - 10 / 1,295,603

edit columns <>

10 per page

1 / 129,561

☐	Reg. No	Source	Holder	Reg. Dat	Locarn	Nation	Ind. Prod.	Designations	Designs	Image
☐	ES700000000	ESID	ANDRÉS MORENO TORRES	2015-08-3	11-02		Esculturas	ES	9	
☐	ES700000000	ESID	SERGIO PESTAÑA CAMACHO	2015-08-3	02-02		CHALECOS	ES	4	
☐	ES700000000	ESID	F2WORK TRABAJOS ESPECIALES S.L.	2015-08-3	06-03		Banco de trabajo	ES	5	
☐	ES700000000	ESID	INNOVACION BAÑO, S.L.	2015-08-2	23-01		VALVULA DE DESAGÜE PARA SANITARIOS	ES	1	
☐	157901	CA ID	HUSQVARNA AB	2015-08-2		CA.003-	CONNECTOR NUT	CA	1	
☐	150851	CA ID	ECO GUTTER IP HOLDINGS PTY LTD.	2015-08-2		CA.018-	GUTTER SECTION	CA	1	

# Search by national classification as well as Locarno

## Global Design Database

A world-wide collection of design registrations and information

**SEARCH BY**

Design Names Numbers Dates Country

Indication of Products =

Design class =  >

- LC.01-01: *Waffles*
- LC.07-02: *Waffle* irons
- J.P.C5-41100F: Pots, Grills, Hot Plates - *Waffle* Iron S
- U.S.D07-410: - Warming or cooking - Grid, grille, hold - *Waffle*

?

**FILTER**

Lookup individual design classes

Class Description =

Code =

search

Current Search

DESC:"ice cream" ✕

clear

1 - 21 / 21

Description	Type	Code
Ice cream	LC	01-01
Ice cream cornets [edible]	LC	01-01
Ice cream goblets	LC	07-01
Vessels for making ice cream, non-electric	LC	07-04
Scoops for ice cream	LC	07-99
Ice cream cornets [containers]	LC	09-05
Ice cream drip guards	LC	09-99
Ice cream sticks	LC	09-99
Ice cream cornets (Automatic vending machines for —)	LC	20-01
Ice cream freezers, electric	LC	31-00
Ice Cream Cone Cup	JP	A1-191

← back

◀ 1/2 ▶

## Hague Registration

Current Status History

### Designated contracting parties:

All EM

### Invalidation: EM: Bulletin No. 41/2012

**(11) Registration Number**

DM/070593

**(73) Name of holder**

LIMITED LIABILITY COMPANY "LOGOS"  
249, Geroev Stalingrada Street, Dnipropetrovsk (UA)

**(81) Designated Contracting Party which pronounced the invalidation, followed by its effective date where that date was communicated to the International Bureau**

EM; 03.05.2012

**(58) Date of recording in the International Register**

11.09.2012

### Statement of Grant of Protection: EM: Bulletin No. 10/2008

**(11) Registration Number**

DM/070593

**(81) Designated Contracting Party which made the notification**

EM

**(58) Date of recording in the International Register**

# GLOBAL DATABASES, TOOLS, AND PLATFORMS FOR IP BUSINESS (FREE)

- PATENTSCOPE
- Global Brand Database
- Global Design Database
- WIPO Lex
- WIPO Pearl





## WIPO Lex

WIPO Lex is a one-stop **search facility** for national laws and treaties on intellectual property (IP) of WIPO, WTO and UN Members. It also features related information which elaborates, analyzes and interprets these laws and treaties. It provides streamlined access to reference material of key importance for optimal information on the global IP System.

- [About WIPO Lex](#)
- [Contact us](#)

[Members' Profiles](#)  
[Treaty Secretariat](#)  
[WIPO-WTO Common Portal](#)  
[Glossary](#)

[IP Legislation](#)[Treaties](#)[Full Text Search](#)

WIPO/WTO/UN Members

Select a Member

Afghanistan (14)  
Albania (34)  
Algeria (26)  
Andorra (16)  
Angola (22)

Subject Matter

Select a Topic

[Search WIPO Lex](#)[Reset](#)

WIPO/WTO/UN Members

Select a Member

Afghanistan (14)  
 Albania (34)  
 Algeria (26)  
 Andorra (16)  
 Angola (22)

Subject Matter

Select a Topic

Select a Topic

Alternative Dispute Resolution (ADR)  
 Competition  
 Copyright and Related Rights (Neighboring Rights)  
 Domain Names  
 Enforcement of IP and Related Laws  
 Genetic Resources  
 Geographical Indications  
 Industrial Designs  
 Industrial Property  
 IP Regulatory Body  
 Layout Designs of Integrated Circuits  
 Patents (Inventions)  
 Plant Variety Protection  
 Trade Names  
 Trademarks  
 Traditional Cultural Expressions  
 Traditional Knowledge (TK)  
 Transfer of Technology  
 Undisclosed Information (Trade Secrets)  
 Utility Models  
 Other

## News on IP Laws

December 10, 2013 [South Africa: The Intellectual Property Laws](#)  
 shall come into force on a date to be fixed by the Minister of Trade and Industry. The new laws will provide for the protection of indigenous knowledge and to create a system for the protection of indigenous knowledge in South Africa. To that end, it amends the existing intellectual property laws, namely, the [Performers' Rights Act 1993](#) and the [Designs Act 1993](#).

October 18, 2013 [Philippines: The BOT Office Order No. 13-06, Series of 2013, on the Implementation of the Guidelines for Office Order No. 13-061, Series 2013, on Trademark Applications with Priority Right Claim](#), issued by the Bureau of Trademarks (BOT) on October 18, 2013, provides for the guidelines to ensure the accurate implementation of the Office Order No. 13-061, which became effective on May 2, 2013. These guidelines primarily refer to the pending trademark applications at the time the Order became effective, the requirement of a copy of the foreign application as a basis for claiming convention priority, the application of goods and services in the Philippines compulsorily covered by the applications used as basis for claiming convention priority, the national applications where fees are not paid in full, the notice of registration of foreign application to the IP office of the Philippines (the IPOPHL) and the conditions for exemption from conformity to the list of goods and services in the foreign registration for the trademark applications for goods and services in the Philippines.



WORLD INTELLECTUAL PROPERTY ORGANIZATION

IP Services

Policy

Cooperation

Reference

About IP

Inside WIPO

Search WIPO



Home | Reference | WIPO Lex

# WIPO Lex

WIPO Lex is a one-stop **search facility** for national laws and treaties on intellectual property (IP) of WIPO, WTO and UN Members. It also features related information which elaborates, analyzes and interprets these laws and treaties. It provides streamlined access to reference material of key importance for optimal information on the global IP System.

- [Members' Profiles](#)
- [Treaty Secretariat](#)
- [WIPO-WTO Common Portal](#)
- [Glossary](#)

[About WIPO Lex](#)

[Contact us](#)

IP Legislation

Treaties

Full Text Search

WIPO/WTO/UN Members

- Indonesia (34)
- Iran (Islamic Republic of) (30)
- Iraq (63)
- Ireland (148)
- Israel (67)
- Italy (162)**

Subject Matter

Select a Topic

Search WIPO Lex

Reset



## Italy (162 texts)

**Quick Access:** [Laws \(102 texts\)](#) | [Implementing Rules/Regulations \(25 texts\)](#) |

[Geographical Indications \(34 texts\)](#) | [Treaty Approvals \(1 texts\)](#) | [Treaty Membership \(95 texts\)](#) |

[Relevant links](#)



### Laws

#### Constitution / Basic Law (Date of current version)

- [Constitution of the Republic of Italy \(2012\)](#)

#### Main IP Laws: enacted by the Legislature (Date of current version)

- [Industrial Property Code \(Legislative Decree No. 30 of February 10, 2005, as amended up to Decree-Law No. 1 of January 24, 2012, converted into law with changes by Law No. 27 of March 24, 2012\) \(2012\)](#)
- [Law No. 633 of April 22, 1941, for the Protection of Copyright and Neighboring Rights \(as amended up to Decree-law No. 64 of April 30, 2010\) \(2010\)](#)
- [Legislative Decree No. 219 of April 24, 2006 on the Implementation of Directive 2001/83/EC \(& Subsequent Amending Directives\) on the Community Code on Medicinal Products for Human Use, and the Directive 2003/94/EC \(2006\)](#)
- [Law No. 109 of June 25, 2005 Conversion into Law, with Amendments of the Decree-Law No. 63 of April 26, 2005 Containing Urgent Provisions for the Development & Territorial Cohesion, as well as for the Protection of Copyright. Provisions Concerning the Adoption of Single Texts on Compulsory & Supplementary Insurance \(2005\)](#)
- [Legislative Decree No. 224 of July 8, 2003 Implementation of Directive 2001/18/EC on the Deliberate Release of Genetically Modified Organisms \(2003\)](#)
- [Regional Act No.11 of 2002 on Protection of Autochthonous Genetic Resources of Agricultural Interest \(2002\)](#)
- [Legislative Decree No. 204 of March 15, 1996 on Amendments and Additions to Legislative Decree No. 685 of 16 November, 1994 concerning Right of Lease and other Copyright-Related Rights \(1996\)](#)

# GLOBAL DATABASES, TOOLS, AND PLATFORMS FOR IP BUSINESS (FREE)

- PATENTSCOPE
- Global Brand Database
- Global Design Database
- WIPO Lex
- WIPO Pearl





# Other systems

- WIPO IPAS, WIPO DAS
- WIPO CASE
- WIPO RE:SEARCH
- WIPO GREEN...



# Take home highlights

- PATENTSCOPE: very powerful full text patent prior art search engine: advised to be used in conjunction with fee-based professional systems for comprehensive searches
- Try the new neuronal WIPO\*Translate
- Global Brand Database: use for internet domain names and trademark searches. Try Image similarity search when Vienna classification searches do not perform

**Thank you for your attention**