

# **Roving Seminar on WIPO Services and Initiatives**



**London, United Kingdom  
April 30, 2018**

# **PARALLEL PROGRAM B (IP/LEGAL PROFESSION)**

## **Recent Developments And The Future Of WIPO Systems**

# Developments of the PCT System



Mr. Michael Richardson, Director,  
PCT Business Development Division,  
PCT Legal and International Affairs Department,  
Patents and Technology Sector (PTS), WIPO

**London, April 30, 2018**

# PCT Coverage Today – 152 States

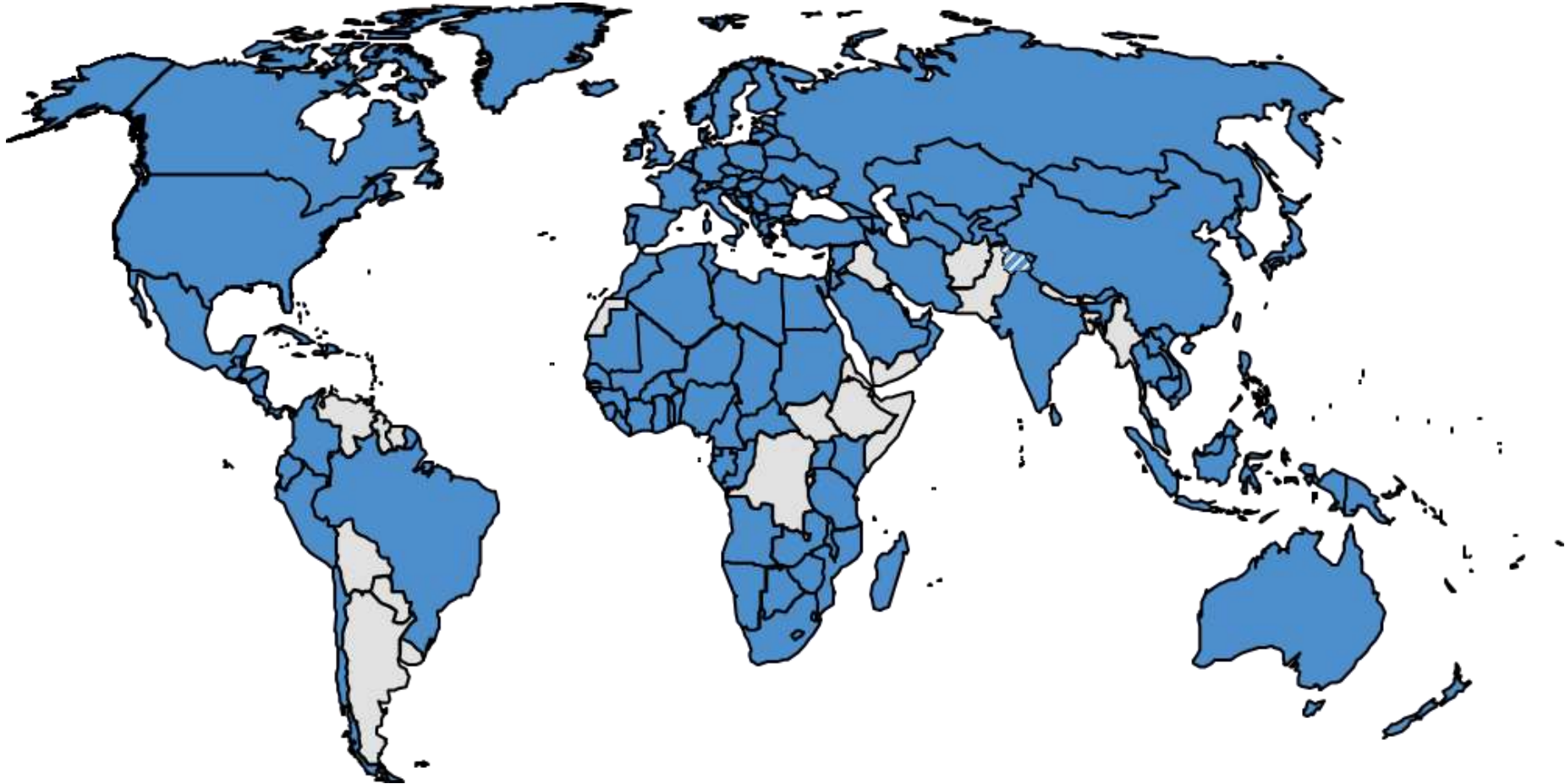

## *Recent accessions:*

Kuwait (June 2016), Djibouti (June 2016),  
Cambodia (September 2016), Jordan (March 2017)

# UN Member States not yet in PCT

Afghanistan	Kiribati	Timor-Leste
Andorra*	Lebanon	Tonga
Argentina**	Maldives	Tuvalu
Bahamas	Marshall Islands	Uruguay**
Bangladesh*	Mauritius**	Vanuatu
Bhutan	Micronesia	Venezuela
Bolivia	Myanmar	Yemen
Burundi	Nauru	
Cape Verde	Nepal	(41)
Democratic Republic of Congo	Pakistan	
Eritrea	Palau	
Ethiopia	Paraguay**	
Fiji	Samoa	<i>Also in discussions</i>
Guyana	Solomon Islands	<i>with GCC Patent</i>
Haiti	Somalia	<i>Office about linking</i>
Iraq	South Sudan	<i>its system to PCT</i>
Jamaica	Suriname*	

\*preparing to accede

\*\*PCT discussions ongoing

# PCT Applications

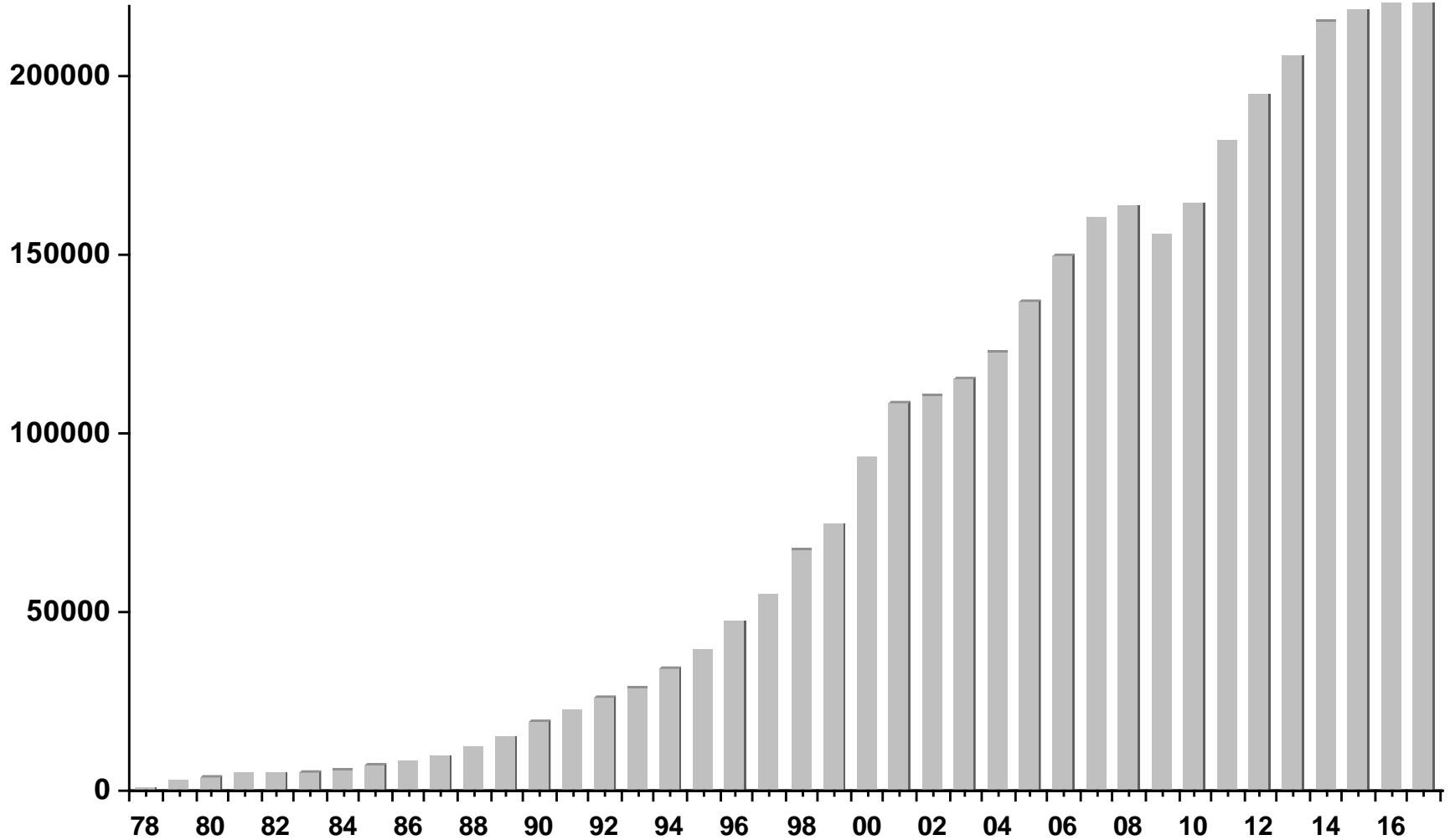

2017: 243,500 (+4.5%)

# GB in the PCT

- #7 filing nation
  - (5,567 international applications by GB residents in 2017, leading to around 21,000 national phase entries)
- 64% file to RO/GB
  - 25% to EP, 5% to IB, 6% other (mainly US)
- Top filers Unilever, Jaguar Land Rover, ARM

# PCT Changes July 2016 (1)

2 additional protections/safeguards for applicants

- Mistakenly filed/submitted “sensitive” information
  - effectively remove from filed PCT applications and publicly accessible application-related documents “sensitive” information mistakenly submitted (amendments to PCT Rules 9, 48 & 94)
  - information sought to be removed must be:
    - irrelevant to the disclosure
    - prejudicial to personal or economic interests, and
    - no prevailing public interest in its access



# PCT Changes July 2016 (2)

- Missed time limits due to large-scale Internet outages
  - extension of *force majeure* excuse of delay provision to time limits missed due to “general unavailability of electronic communications services” (amended Rule 82*quater*)
  - covers outages that affect widespread geographical areas or many individuals, as distinct from localized problems associated with a particular building or single user

# PCT Changes July 2017 (1)

- designated Offices required to provide IB with timely national phase entry and related data (Rules 86 & 95)
- PATENTSCOPE “National phase” tab will contain more information than it currently does
- Information also made available to other patent information service providers

# PCT Changes July 2017 (2)

- PCT “Receiving Offices” required to forward any earlier search or classification results on priority applications to the PCT ISA (amendments to Rules 12*bis*, 23*bis* & 41)
  - Efficiency/work-sharing measure
  - Some exceptions, unlikely to be relevant to GB applicants

# 2017 PCT Assembly

- Reappointed all ISAs/IPEAs
- Appointed new ISA/IPEA Philippines IPO (#23)
- Clarified eligibility for fee reductions for nationals and residents of certain low-income countries

# PCT Working Group 2018

## ■ Workshops

- potential fee reductions for universities
- incorporation by reference of “correct” elements or parts

## ■ Proposals

- PCT fee reductions for universities (BR)
- Further safeguards for outages of IT systems (EP)
- Earlier start of Chapter II (EP)

# Electronic filing

- Moving away from PCT-SAFE/epoline
- Aim:
  - Secure processing via system always up to date
  - Exchange usable data – eliminate transcription errors
- Browser-based interface
  - Web services being developed

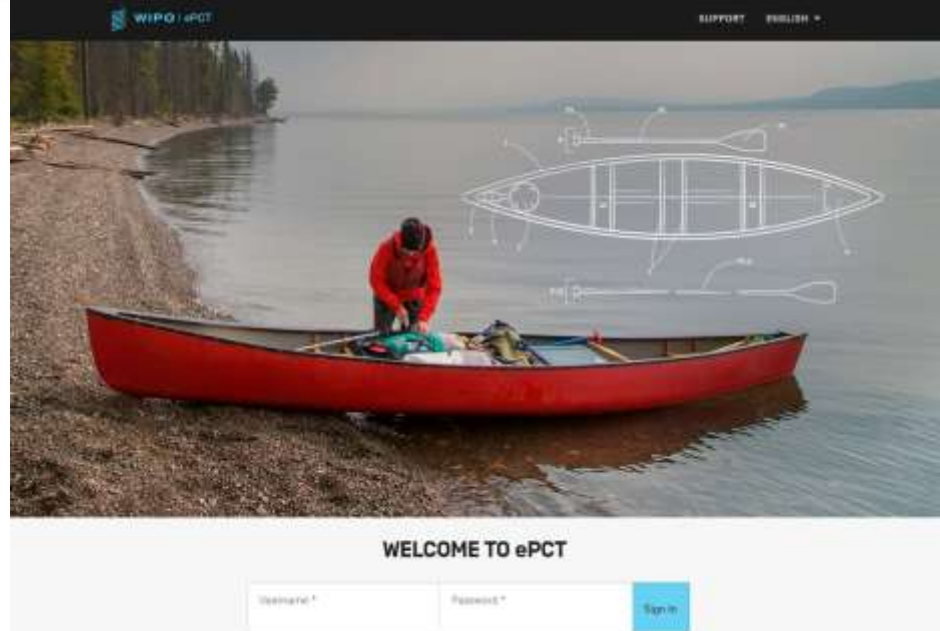

# Electronic Filing (2)

- ePCT integrated in to HFS (EPO's forthcoming filing tool)
  - Aim for as much consistency as possible between Offices
  - Minimize requirements for multiple user accounts and file formats
  
- Issues
  - DOCX filing
  - Color drawings
  - Integration with patent management systems?
  - National phase entry assistance?
  - Centralized payment system?

# Other PCT Issues

- Quality
  - Search and preliminary examination
  - Timeliness and accuracy of administrative actions
  
- IP5 collaborative search and examination
  - 500 PCT applications (100 from each Office) passed to other IP5 Offices for collaborative search
  - selected from requests by applicants
  - beginning July 1, 2018
  - 2 years of international phase tests, follow into national phase
  
- More effective exchange of information



# PCT Information and Training

[www.wipo.int/pct/en](http://www.wipo.int/pct/en)

- Applicant's Guide
- Monthly Newsletter
- Videos
- Distance learning course
- Webinars
- Seminar calendar

# Want Something to Change?

Get involved

- ePCT – contact [pct.eservices@wipo.int](mailto:pct.eservices@wipo.int)

“The fact that the ePCT people at WIPO listen and attempt to improve their system is one of the reasons we like using ePCT.”

- Generally – talk to CIPA – get CIPA to talk to us
- Or tell me now...

# Questions for You

- PCT Inconveniences?
  - Cost?
  - Timeliness?
  - Quality/reliability/predictability?
- Decision-making on use of PCT
  - What factors determine whether you file a PCT application or not?
- “Magic wand”
  - features/functionalities you most wish PCT contained?
  - countries to add?
- Areas where more information or training needed?

# Developments of The Hague System



Ms. Päivi Lähdesmäki  
Head, Development and Promotion Section  
The Hague Registry  
World Intellectual Property Organization (WIPO)

**London, April 30, 2018**

# Hague System : Current and Foreseen Coverage



# **The Expansion to Examining Jurisdictions:**

## **What Impacts?**

# Designating Japan, the Republic of Korea the United States of America and the Russian Federation

- «Examining jurisdictions» under the Hague System:
  - Some declarations may only be made by a CP with an Examining Office (Art.1(xvii) of the 1999 Act);
  - Specific elements required by USPTO, JPO, KIPO and ROSPATENT

# Obvious and Less Obvious Impacts

- More elements/constraints at filing stage
  - ... but intelligent e-filing system keeps it simple
    - Prevention of omission or systemic mistakes
    - Facilitated declarations and claim
    - Links to national websites for guidance
  
- Substantive appreciation by those Offices
  - ... and that's the real game changer



# **UK Filings in Examining Jurisdictions:**

## **How Have They Been Faring?**

# USPTO, JPO & KIPO - Refusal Grounds

Representative sample of refusal recorded up to March 13, 2018 against UK-origin designs

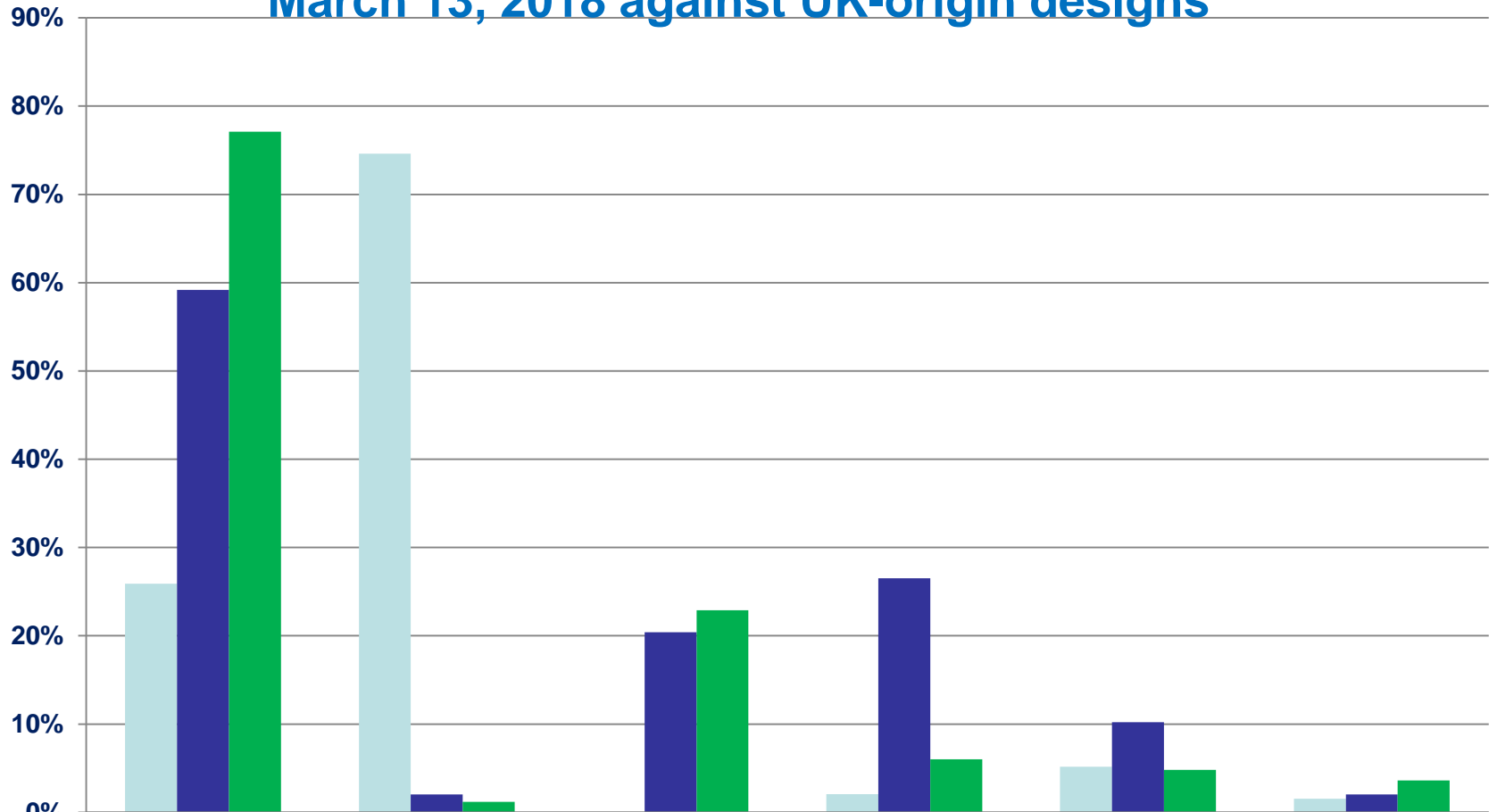

	Insufficient disclosure	Unity of Design	Conflict Appl/Reg	Lack of Novelty	Ambiguous Product Designation	Definition of Design
■ USPTO	25.90%	74.61%	0.00%	2.07%	5.18%	1.55%
■ JPO	59.18%	2.04%	20.40%	26.53%	10.20%	2.04%
■ KIPO	77.10%	1.20%	22.89%	6.02%	4.82%	3.61%

Source: Internal WIPO statistics



**ISSUE COMMON TO ALL  
EXAMINING JURISDICTIONS :  
HOW TO ACHIEVE APPROPRIATE  
DISCLOSURE?**

# Don't confuse disclosure requirement and formal requirements !

- A single set of representations works for all Offices
- Offices cannot reject on formal grounds to:
  - Require, or oppose to surface shading or dotted line
  - Oppose to photographs, color or CADs
  - Require a description
  - Require a legend
- It's your liberty under the Hague to use these or not
- ... but using them or not has an impact on your disclosure

# Success Stories:

These cases accepted by all of the US, JP and KR Offices !



DM/92589 DM/95101 DM/89713  
DM/92108 DM/89858 DM/89019

http://www.wipo.int/hague/en/ Hague – The International ...

File Edit View Favorites Tools Help

Media Meetings Contact Us My Account English

**WIPO**  
WORLD INTELLECTUAL PROPERTY ORGANIZATION

IP Services Policy Cooperation Knowledge About IP Inside WIPO Search WIPO

Home > IP Services > Hague System

## WIPO | HAGUE

### Hague – The International Design System

The Hague System for the International Registration of Industrial Designs provides a practical business solution for registering up to 100 designs in over 66 territories through filing one single international application.

Learn more:

- [What is an industrial design?](#)
- [Main features and advantages](#)
- [Geographical coverage and legal framework](#)
- [FAQs](#)



[Read the case study.](#) (Photo: Jeff Harris/Artnix; RoundTAIL)

## Guidance on Preparing and Providing Reproductions in Order to Forestall Possible Refusals on the Ground of Insufficient Disclosure of an Industrial Design by Examining Offices

### News

[2017 Hague Yearly Review available](#)   [Strong growth in international design applications in 2016](#)

# Provide Enough Views



1.1



1.2

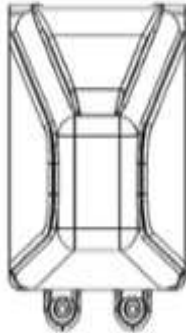

1.3

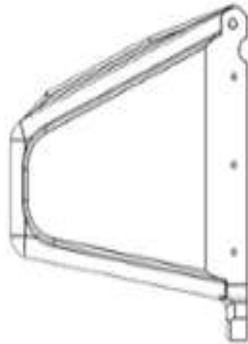

1.4

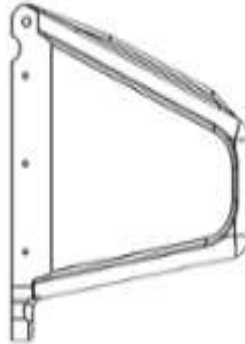

1.5



1.6



1.7



1.1) Perspective; 1.2) Front; 1.3) Left; 1.4) Right; 1.5) Back; 1.6) Top; 1.7) Bottom

## It's Always Safer with a Legend

[DM/092-108](#) for a "security bulwark"

# Use the «description» to justify absent views

- DM/088980: “front view is omitted because it is identical with the back view; right side view is omitted because it is identical with the left side view”

1.1



1.1) Perspective

1.2



1.2) Perspective

1.3

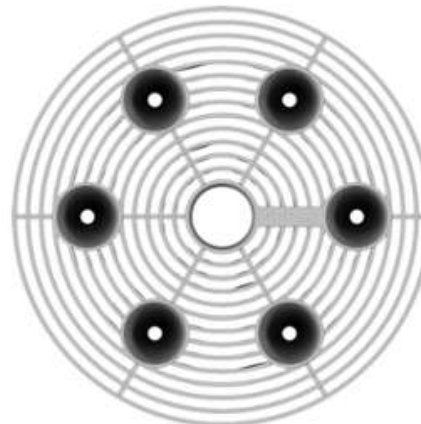

1.3) Top

1.4

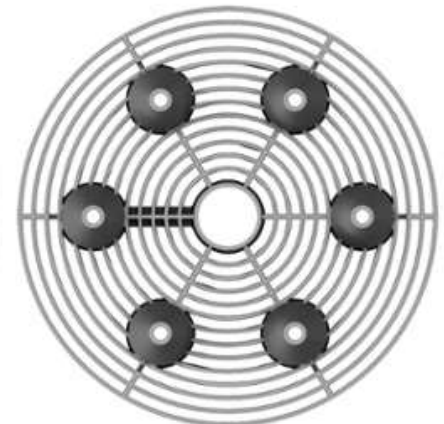

1.4) Bottom

1.5



1.5) Left

1.6



1.6) Back



# What Went Wrong Here?

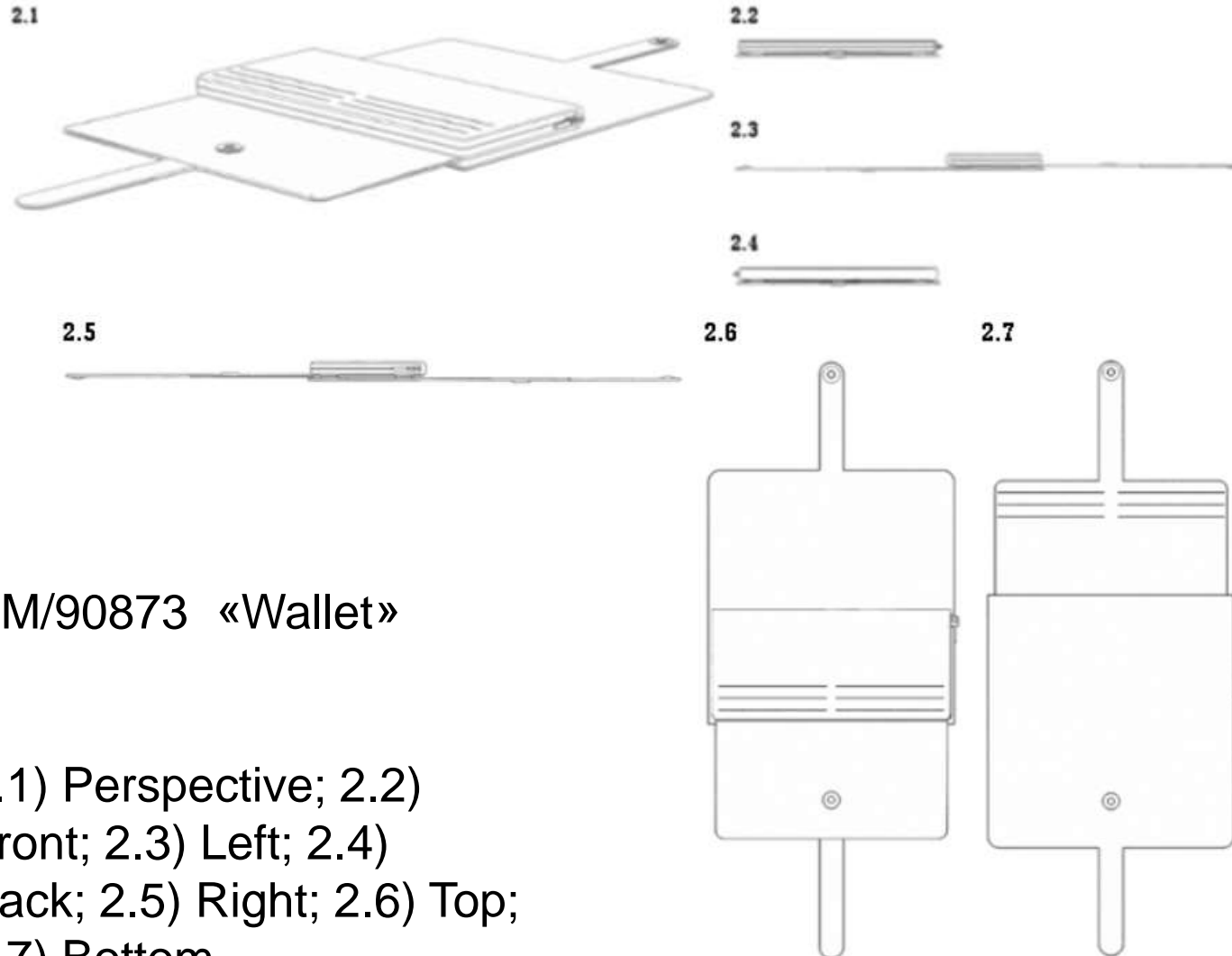

DM/90873 «Wallet»

2.1) Perspective; 2.2)  
Front; 2.3) Left; 2.4)  
Back; 2.5) Right; 2.6) Top;  
2.7) Bottom

2.1



2.1) Perspective

## JPO Refused because...

The design in this application for design registration is not a specific design because of the following reason:

The state of use and the method of use of "Wallet" as shown in the indication of product in this application for design registration cannot be derived from the reproductions, and the design is not specific.

(The method on how to fold "Wallet" and the state where it is folded are not clear. It is also not clear whether the lines shown on the surface of "Wallet" indicate a pattern or card slots.)

# Shading lines not explained = Refusal

Refusal by  
JPO :

A single definite design cannot be identified.

Thin lines are shown on the surface in the reproduction of this design; however, the meaning of these lines is not stated in DESCRIPTION.

Accordingly, it is unclear whether these thin lines constitute surface pattern or not.

1.1

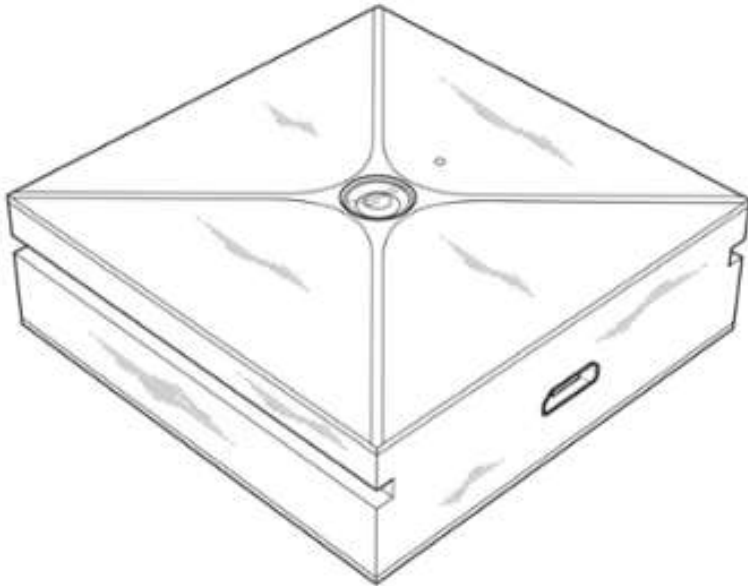

1.2

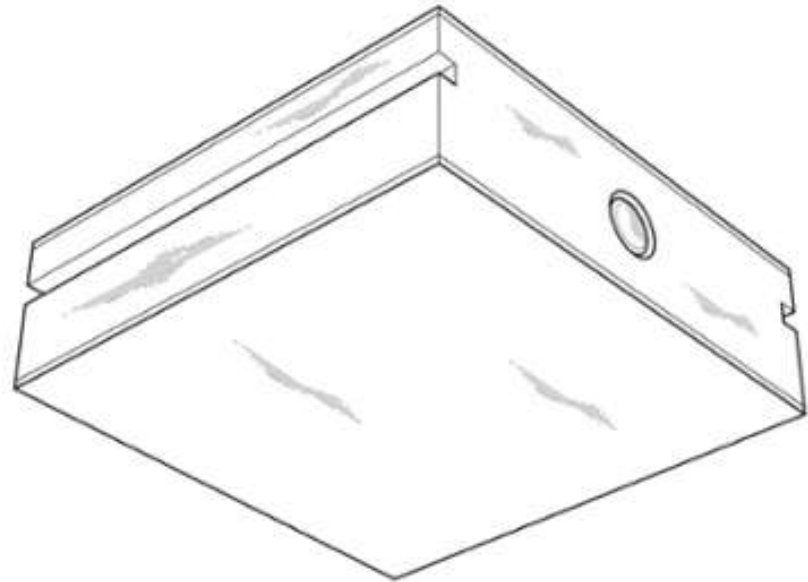

# Also Explain Presence of Dotted Lines

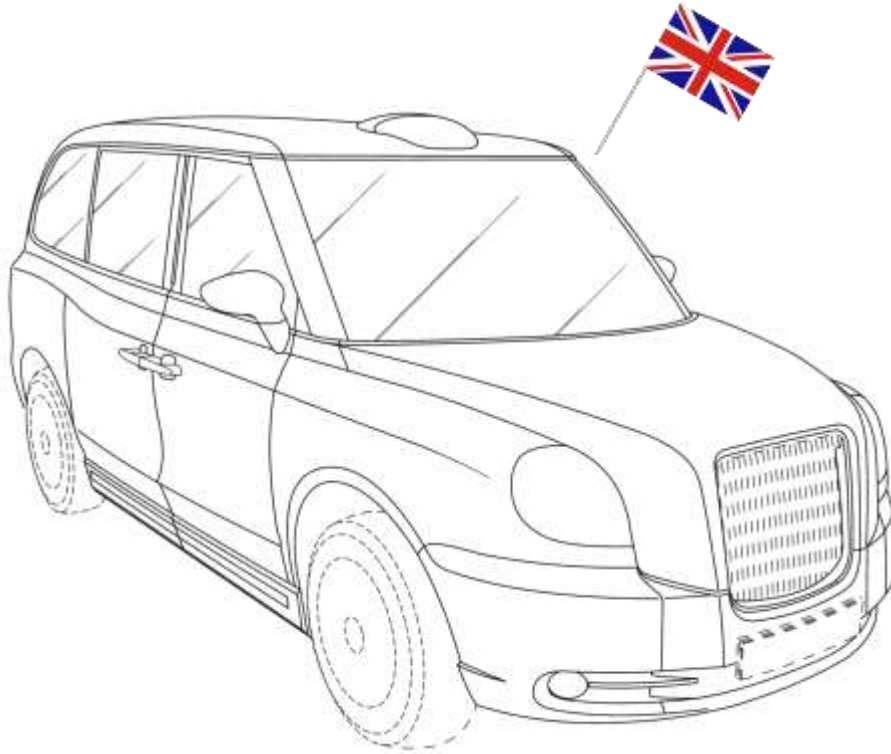

1.3

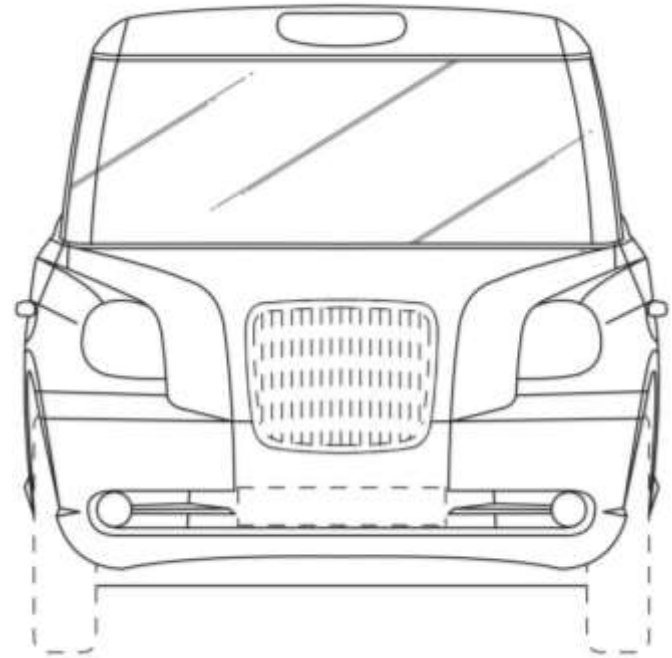

DM/91054 -

*“No protection is sought for the matters shown in dotted lines”*

# Be consistent amongst all views

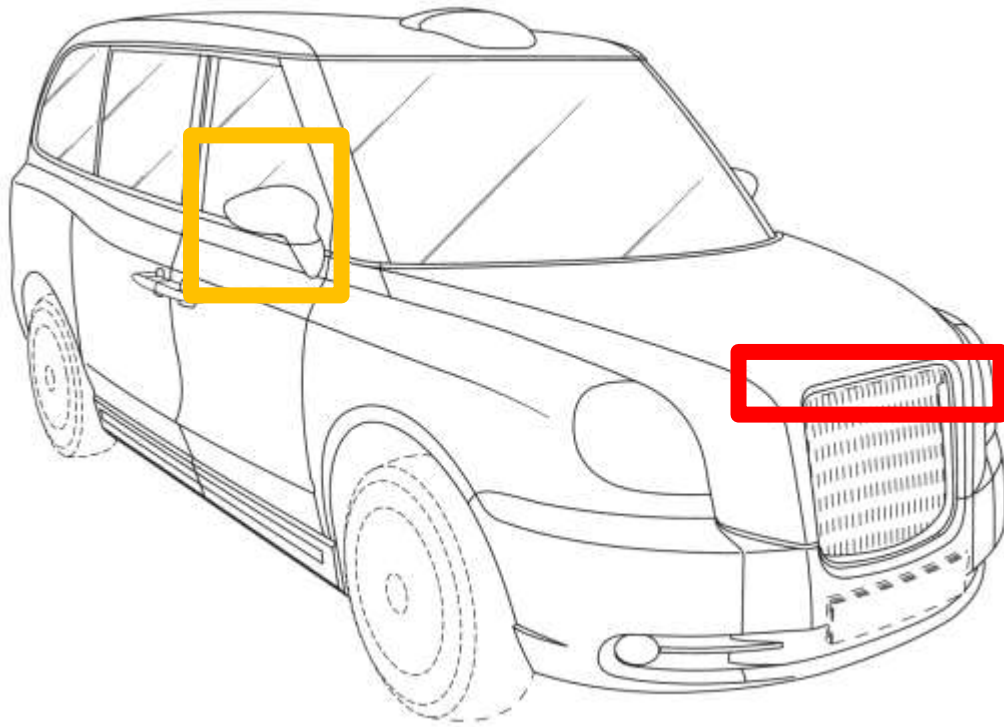

1.3

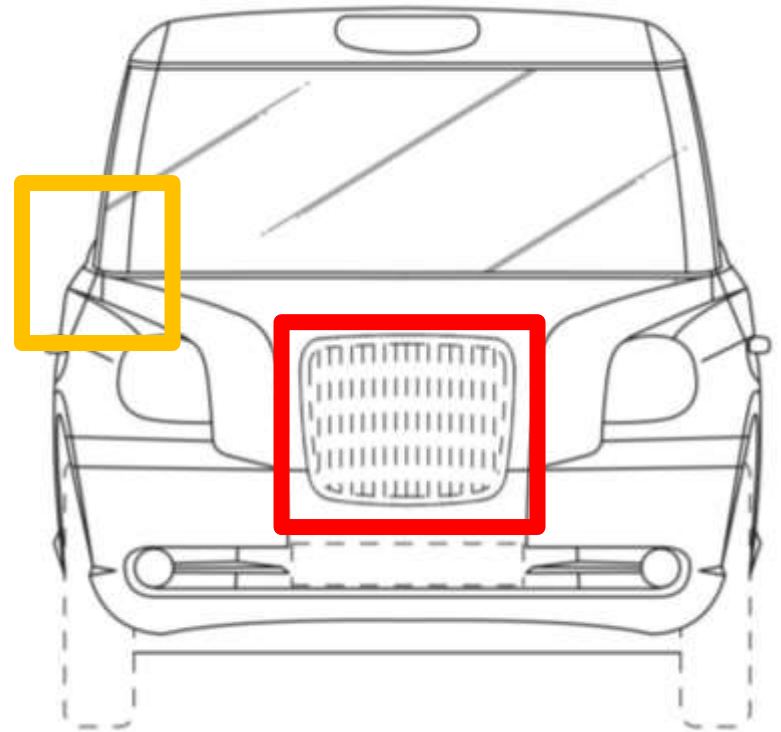

# Avoid mixing reproduction styles

1.1

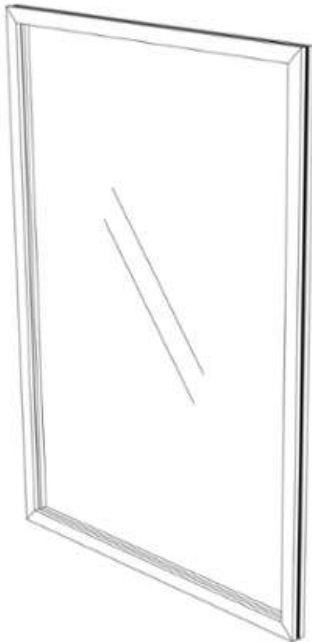

1.2



1.3



1.4

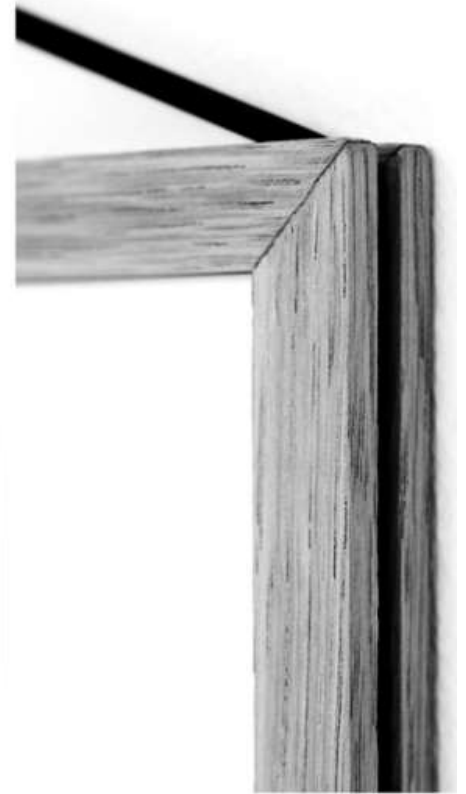

High risk that Inconsistencies be detected and lead to a substantive refusal!



# **ISSUE COMMON ALL :** **PRODUCT INDICATION**

# Product indication: be as specific as possible

1.1

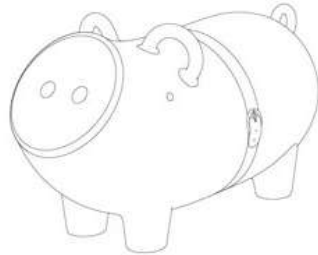

1.2

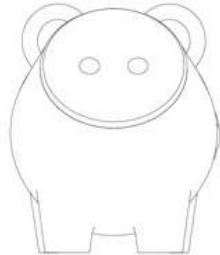

1.3

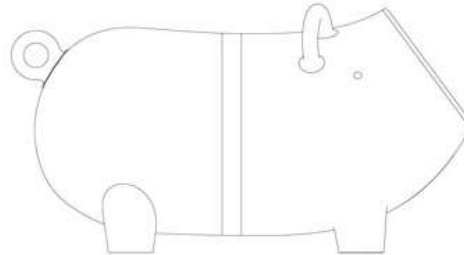

1.4

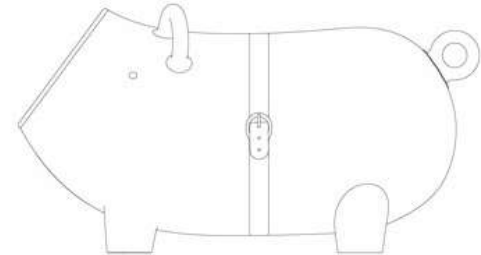

1.5

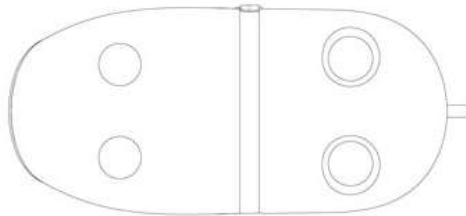

1.6



1.7

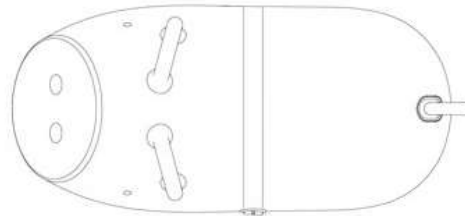

- JPO: «Toy» changed into «Riding Toy»
- Note : description *did* say «Toy to sit on in the form of a pig”...



# Couple More Things on Product Indication

- Japan and Korea: don't file «logos», etc...
- USA : be consistent with your claim
  - IB will help prevent formal mistakes only
  - The claim is for one design (the 1st by default)



**ISSUE SPECIFIC TO THE USA (AND  
NOW ALSO RUSSIA):**

**UNITY OF DESIGN**

# Unity of Design

Indistinct designs or obvious variations:

**DM/086900:** Designs 1-4, 7-11 “Toothbrushes”;

Designs 5-6 “Toothbrush heads”

1.1



2.1



3.1



4.1



5.1



6.1

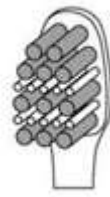

7.1



8.1



9.1



10.1



11.1



# Unity of Design

Indistinct designs or obvious variations:

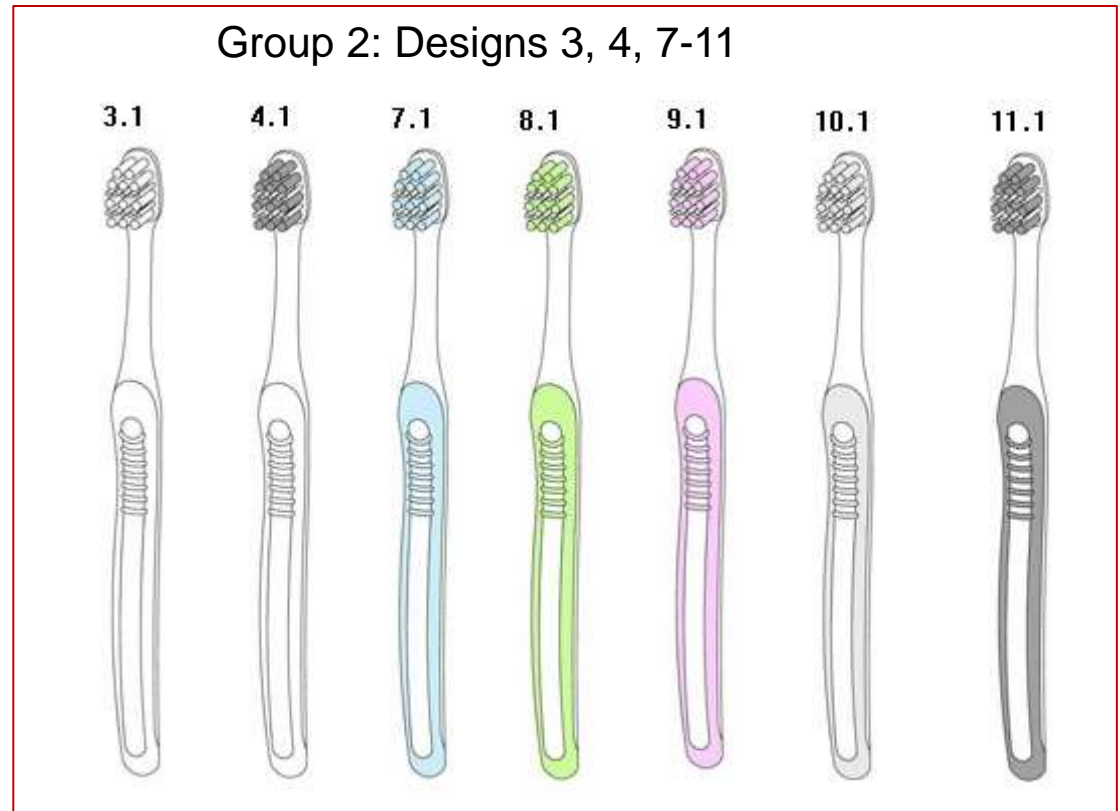
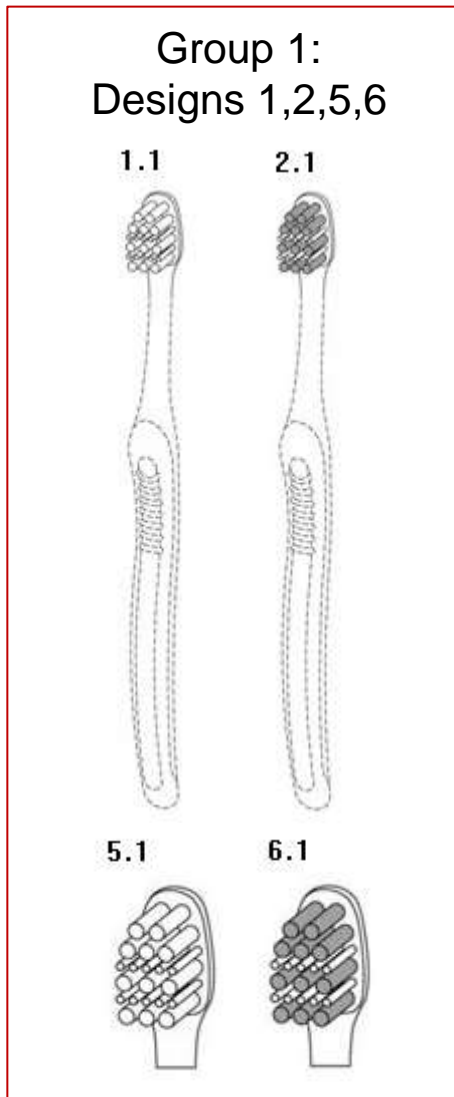

Designs grouped together have the same basic design characteristics:

- similar in overall appearance
- similar in visual impression
- similar in shape/ configuration



**ISSUES SPECIFIC TO  
JAPAN AND THE REPUBLIC OF  
KOREA:**

**CONFLICT WITH OTHER  
APPLICATION AND  
LACK OF NOVELTY**

# Surprise: it's almost never prior art

- What destroys your novelty in KR and JP is almost always your own design...
  - when designs are similar they destroy each other's novelty
- That's easy to avoid!
  - Identify one as the «principal design»
  - Identify the others as «related designs»

# Identify the Principal and Related Designs in the dedicated e-filing tab

1.1



2.1



1.1



2.1



...think about it even if the first design was filed in another Hague or domestic application!

# Priority Claim Issues

- KR: Attach your priority document under dedicated tab
- JP: File your priority document with JPO
- RU: File your priority document with Rospatent

➤ *Why don't you make the IA the priority application?*



**CONCLUSION:**  
**MOST REFUSALS CAN BE EASILY**  
**OVERCOME...**  
**BUT COULD HAVE BEEN EASILY**  
**AVOIDED TOO!**

# Shy, still? Here are a few incentives...

- In Japan:
  - Domestic applications must be single design only
  - But multiple design IRs are not refused!
- In **all** examining jurisdictions:
  - No provisional rights for domestic applications
  - But provisional rights for IRs from publication!

# Success Stories from the UK

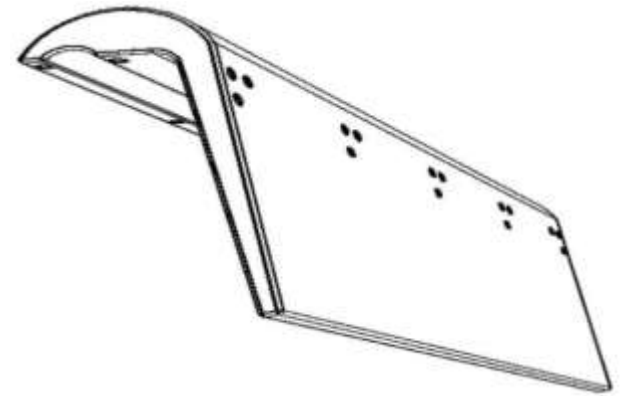

DM/92589 DM/92567 DM/95951  
DM/92108 DM/96359 DM/91433

# A 34/35 Score...

DM/091 895

Designated Jurisdictions: AL, AM, AZ, BA, BN, BW, CH, EG, EM, GE, GH, IS, JP, KG, KR, LI, MC, MD, ME, MK, MN, NA, NO, OA, OM, RS, RW, SG, ST, **SY**, TJ, TM, TN, TR, UA

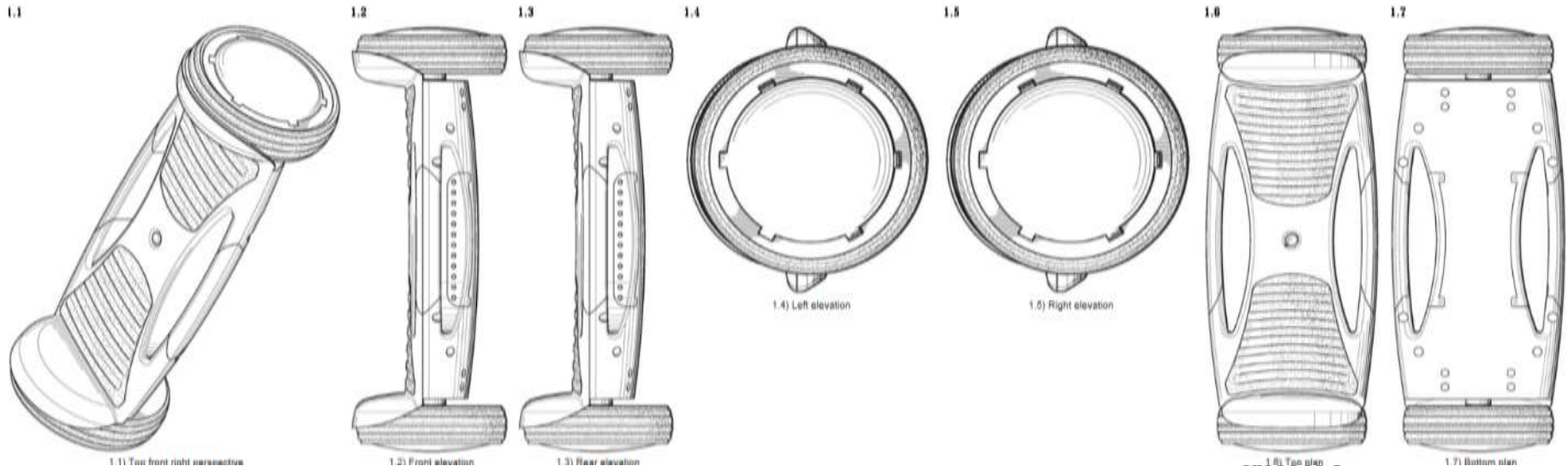

# The Hague System for Examining Jurisdictions : It Works!



MORE INFO ON THE HAGUE SYSTEM AT:

[www.wipo.int/hague/en](http://www.wipo.int/hague/en)

<https://www3.wipo.int/newsletters/en/#haguenotices>



# **Discussion: The Future of the Hague System; Going Global**

Ms. Päivi Lähdesmäki  
Head, Development and Promotion Section  
The Hague Registry  
World Intellectual Property Organization (WIPO)

**London April 30, 2018**

# Hague System : Current and Foreseen Coverage

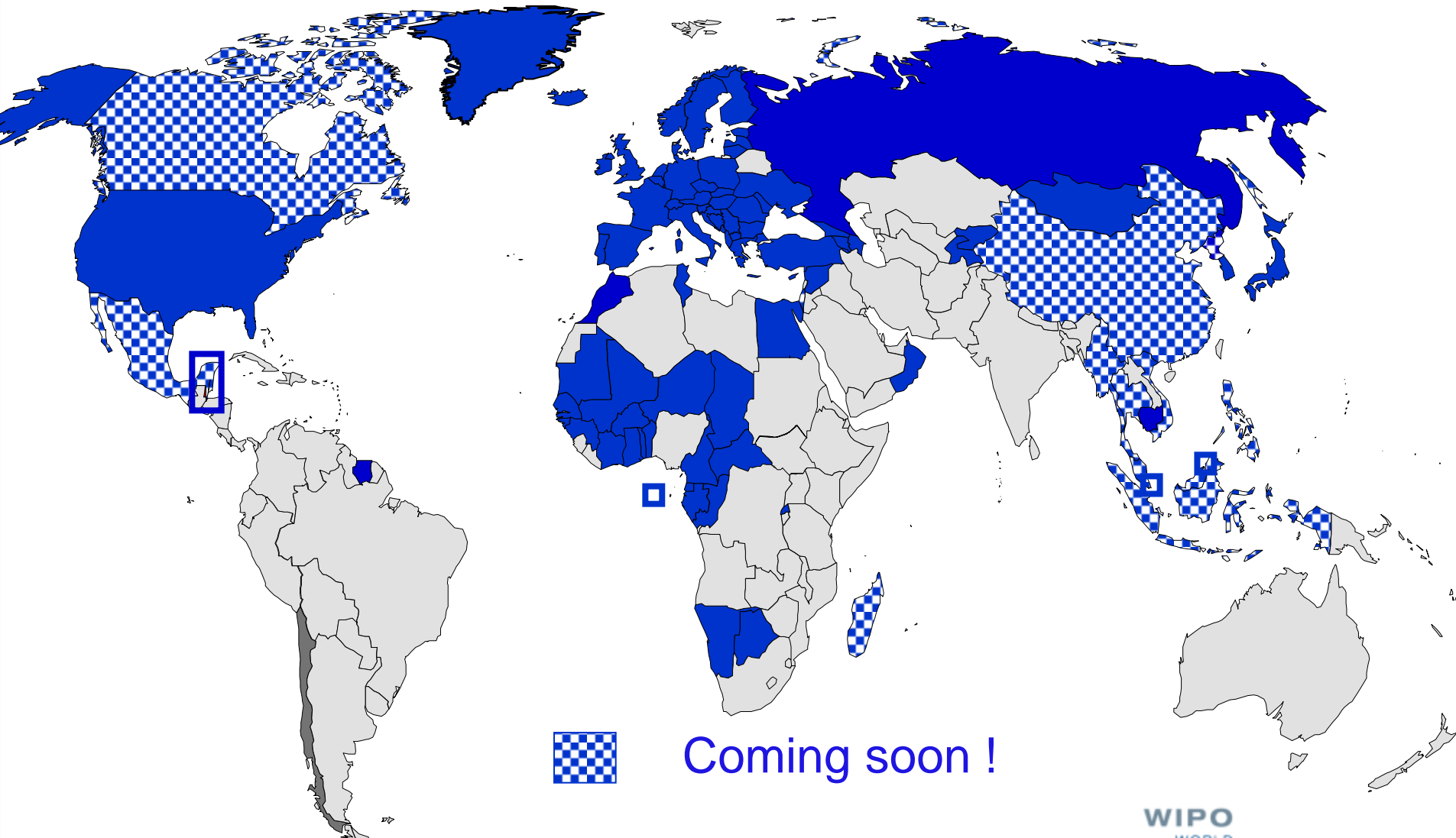

# International Applications - 2017



5,213 international applications were received containing 19,429 designs (max. 100 designs / application)



6.27 % decrease compared to the respective period in 2016 in the number of applications



3.8% growth compared to the respective period in 2016 in the number of designs



# Going Global

- 2018/2019: ASEAN countries, Belize, Canada, China, Israel, Madagascar, Mexico, Morocco,...
- China: 2016
  - 631,949 resident design filings; 18,395 non-resident filings;
  - 159,389 design filings abroad  
(source: WIPO IP Statistics Data Center)

# Most designated Contracting Parties in 2017 (number of designs recorded)

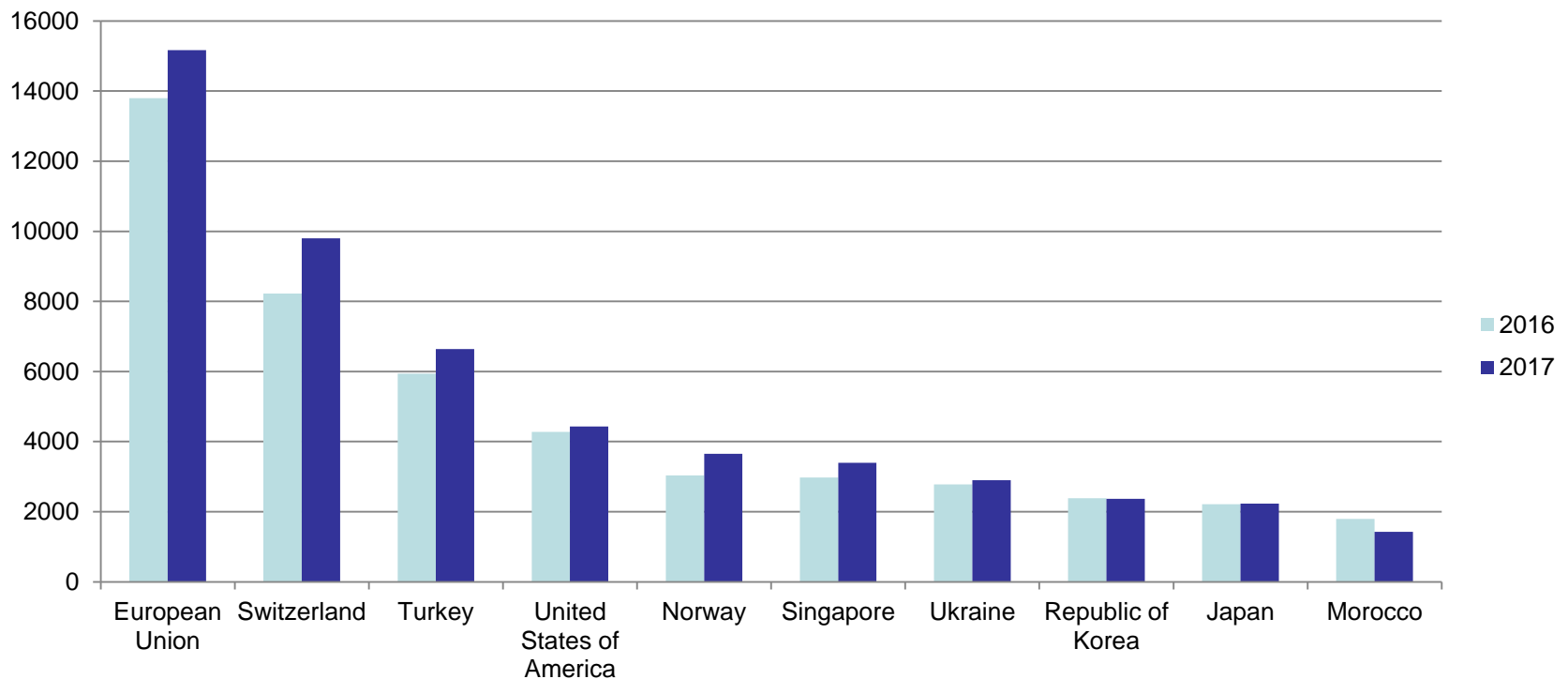

# Origin of Filers of International Applications (by Country of Address of the Applicant) - 2017

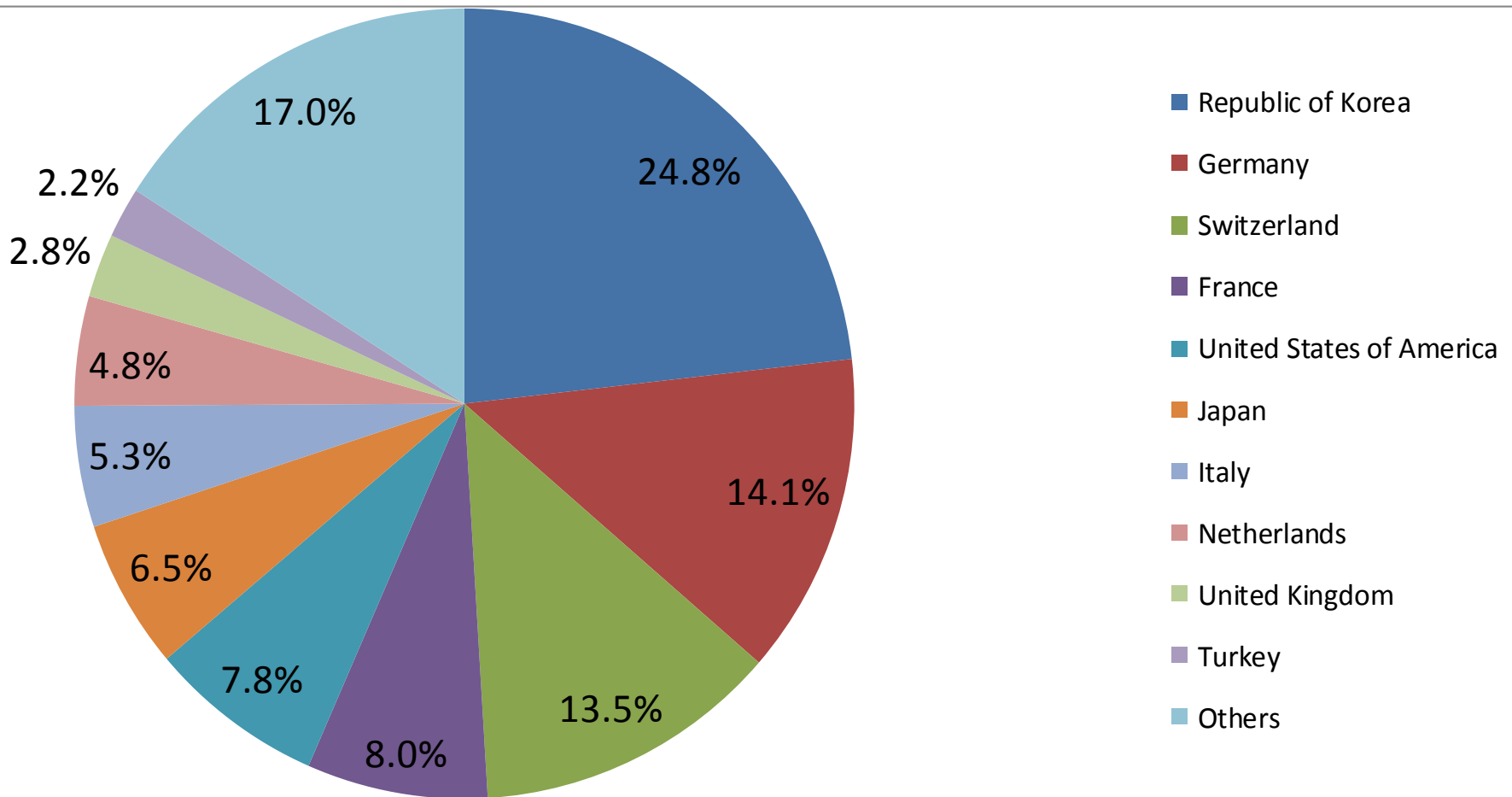

# Origin of Filers per Designs in International Applications

(by Country of Address of the Applicant) - 2017

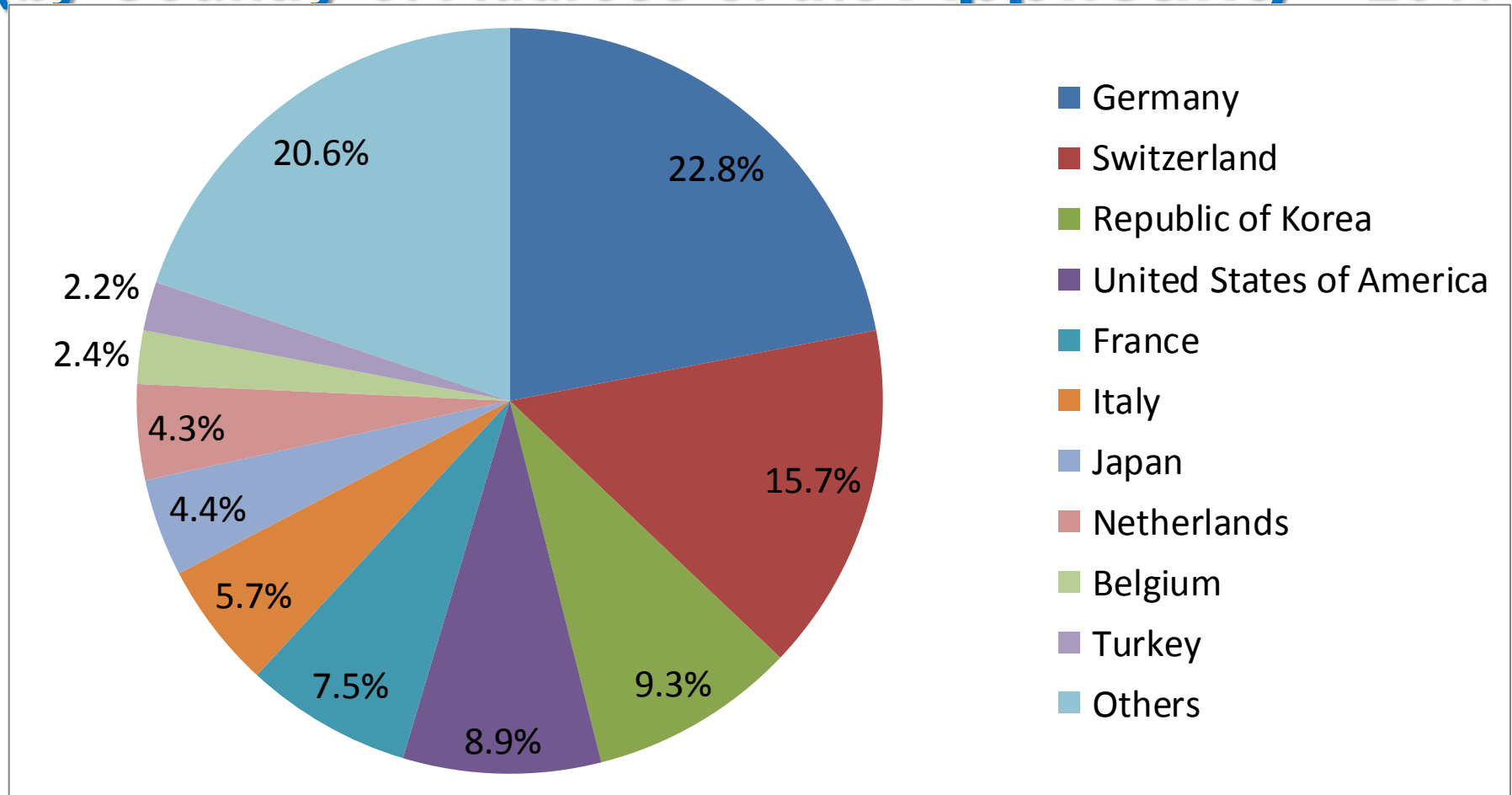

# Developments of the Madrid System



Mr. Matthew Forno, Senior Counsellor,  
Madrid Information and Promotion Division,  
Madrid Registry, Brands and Designs Sector  
(BDS), WIPO

**London, April 30, 2018**

# Accession Outlook 2018/19

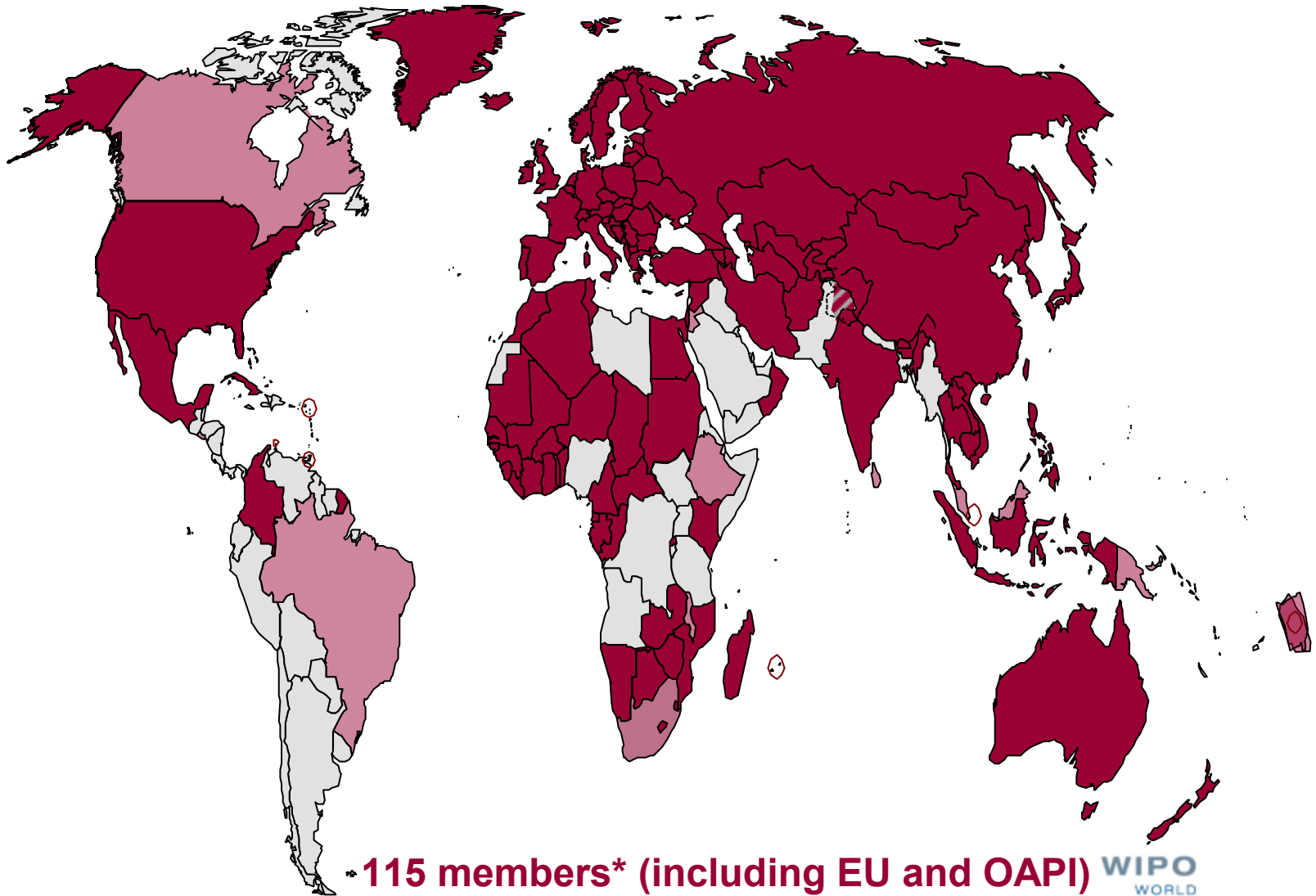

→ **115 members\* (including EU and OAPI)  
covering 131 countries**

# International Applications

Figure A.1.1 Trend in international applications

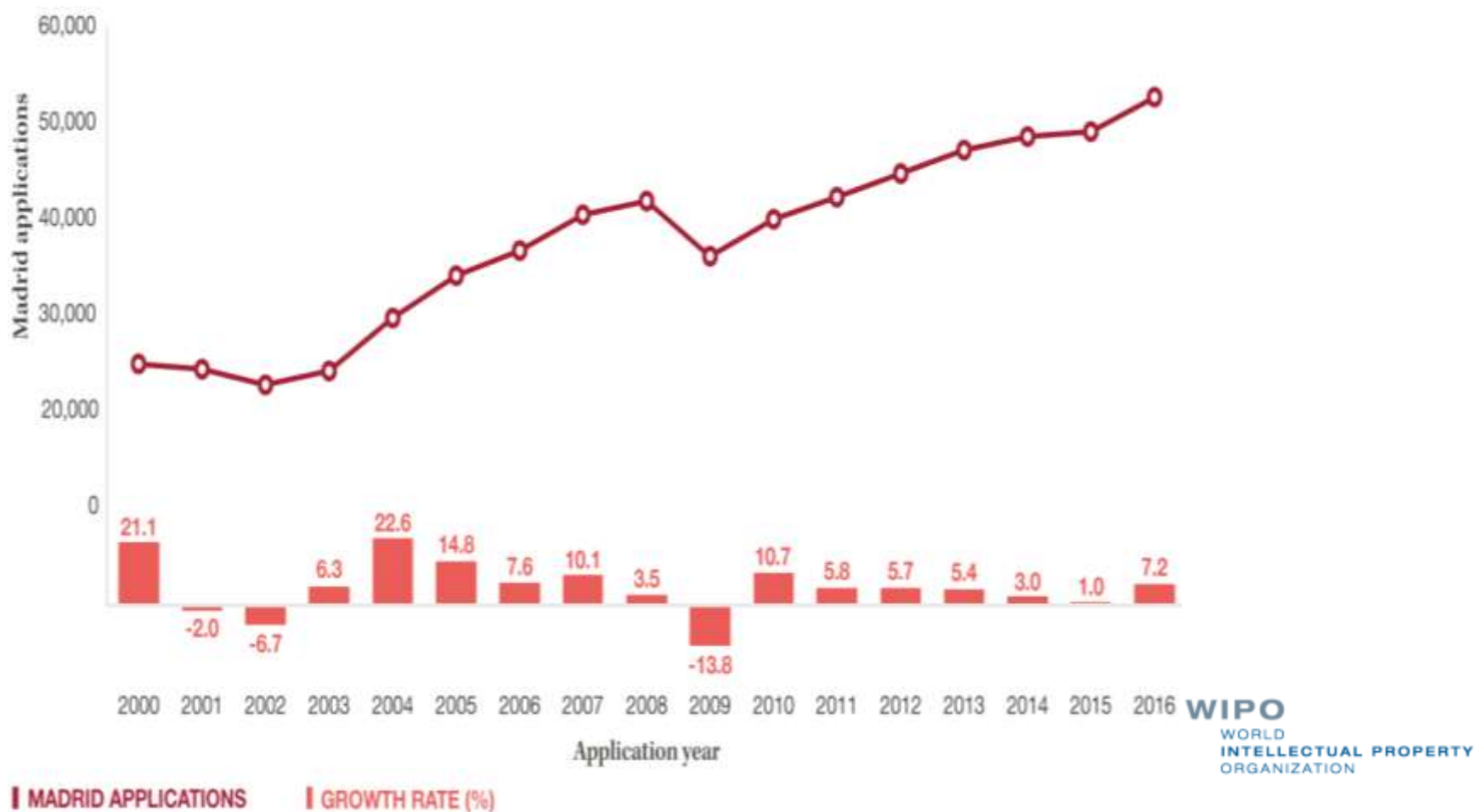

# Top Ten Filing Origins

## TOP 10 COUNTRIES

Number of Madrid applications and % growth since 2016

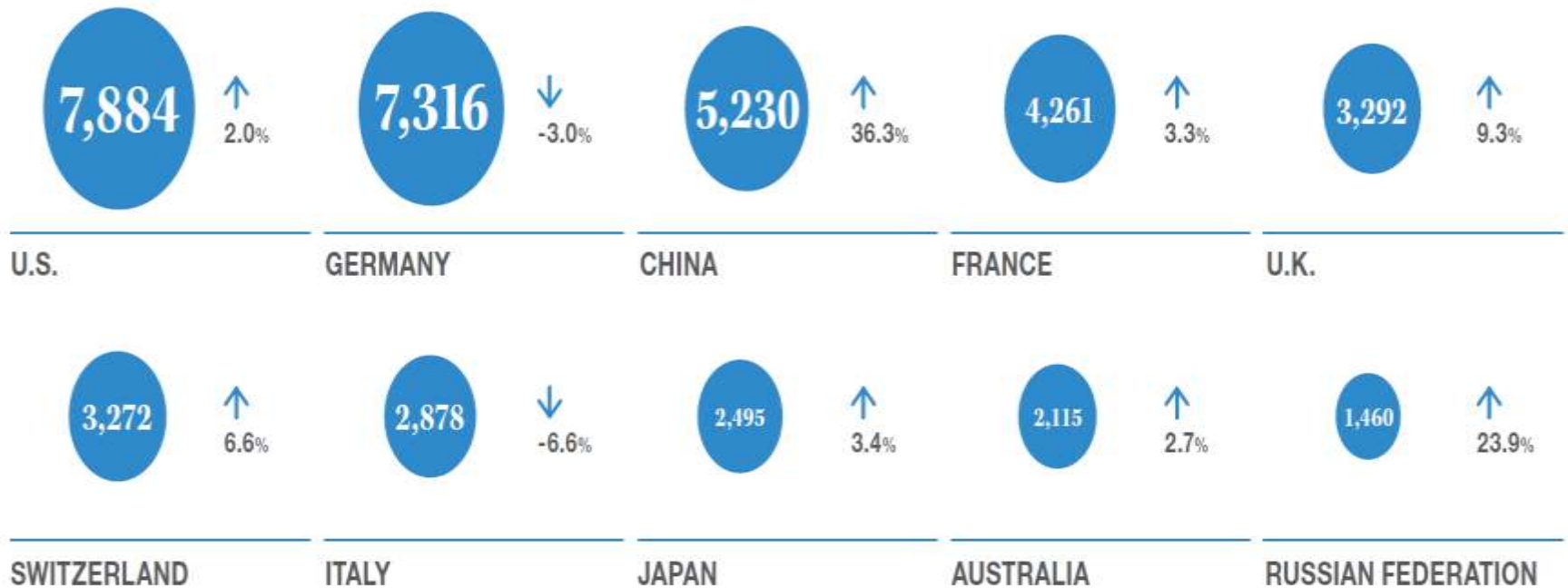



# Top Ten Designated Contracting Parties

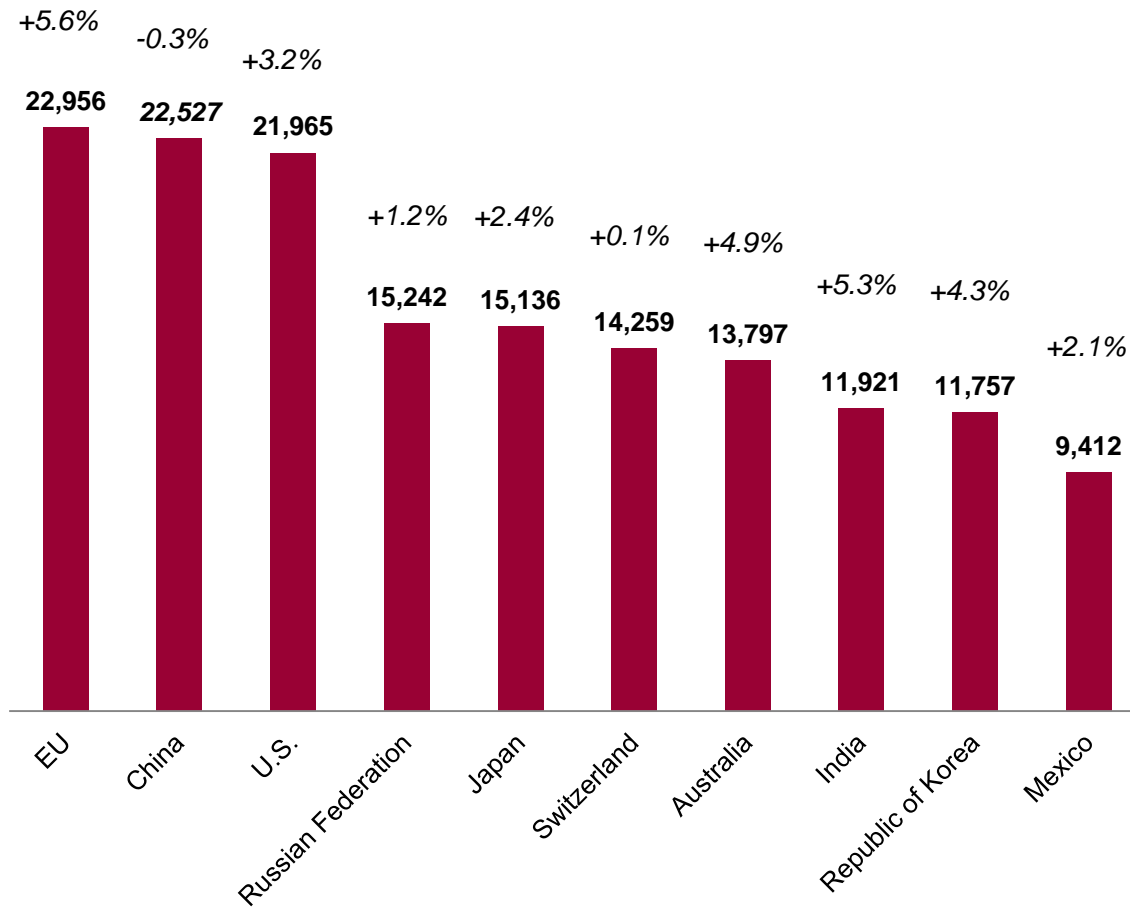

# Top Applicants

#	Name	Origin	Applications
1	L'ORÉAL	France	198
2	RICHTER GEDEON NYRT.	Hungary	117
3	ADP GAUSELMANN GMBH	Germany	104
4	NOVARTIS AG	Switzerland	96
5	ABERCROMBIE & FITCH EUROPE SA	Switzerland	82
6	APPLE INC.	US	74
7	BRILLUX GMBH & CO. KG	Germany	73
7	KRKA, TOVARNA ZDRAVIL, D.D., NOVO MESTO	Slovenia	73
8	BAYERISCHE MOTOREN WERKE AKTIENGESELLSCHAFT	Germany	70
9	AUCMA COMPANY LIMITED	China	62
9	JANSSEN PHARMACEUTICA N.V.	Belgium	62

WIPO

WORLD  
INTELLECTUAL PROPERTY  
ORGANIZATION

# Top Five Classes

13,646

COMPUTERS AND  
ELECTRONICS



9.8%

11,079

SERVICES FOR  
BUSINESS



7.9%

8,607

TECHNOLOGICAL  
SERVICES



6.2%

6,587

LEISURE, EDUCATION  
AND TRAINING  
SERVICES



4.7%

6,239

PHARMACEUTICALS



4.5%

# International Applications and Registrations and United Kingdom

International Applications and Registrations by Office of Origin: UK

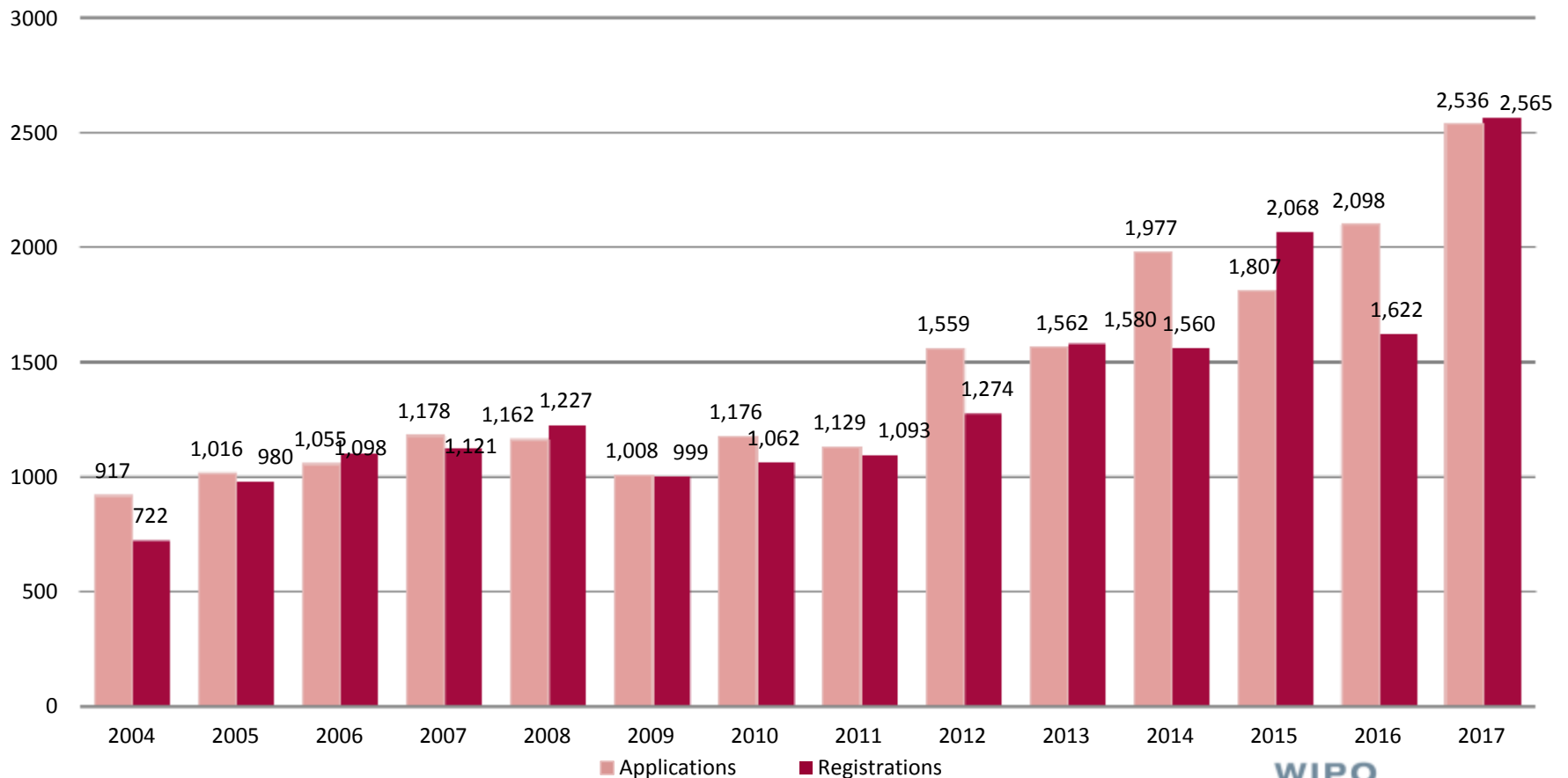

# Top Designated Contracting Parties: UK Holders

Designations in international registrations & subsequent designations by DCPs, Country of Holder: United Kingdom (2016)

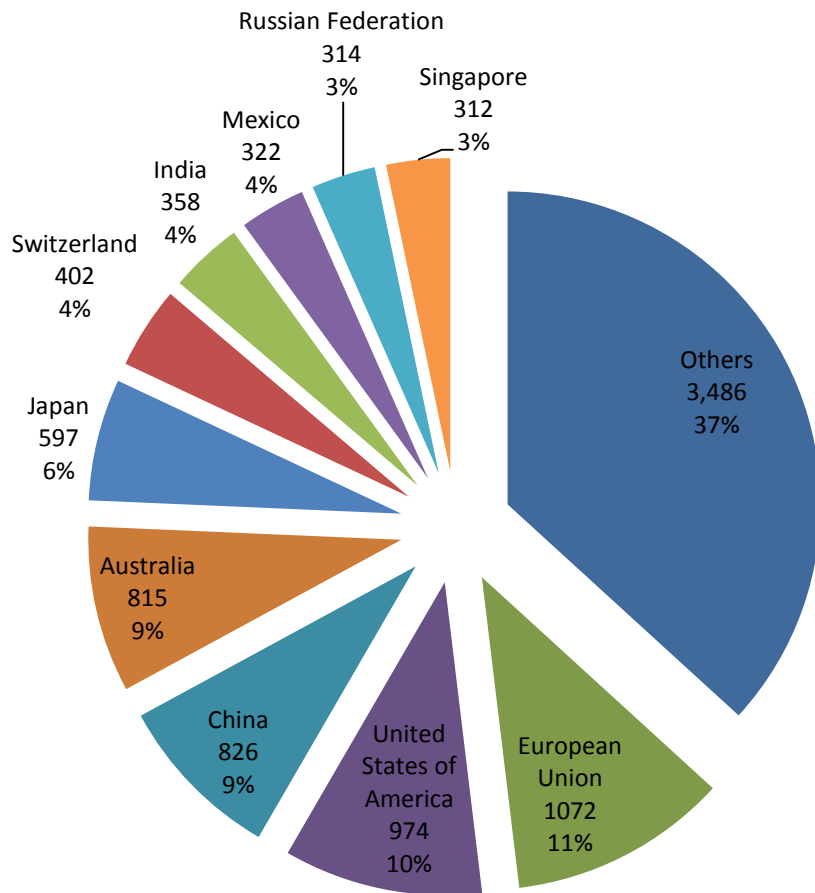





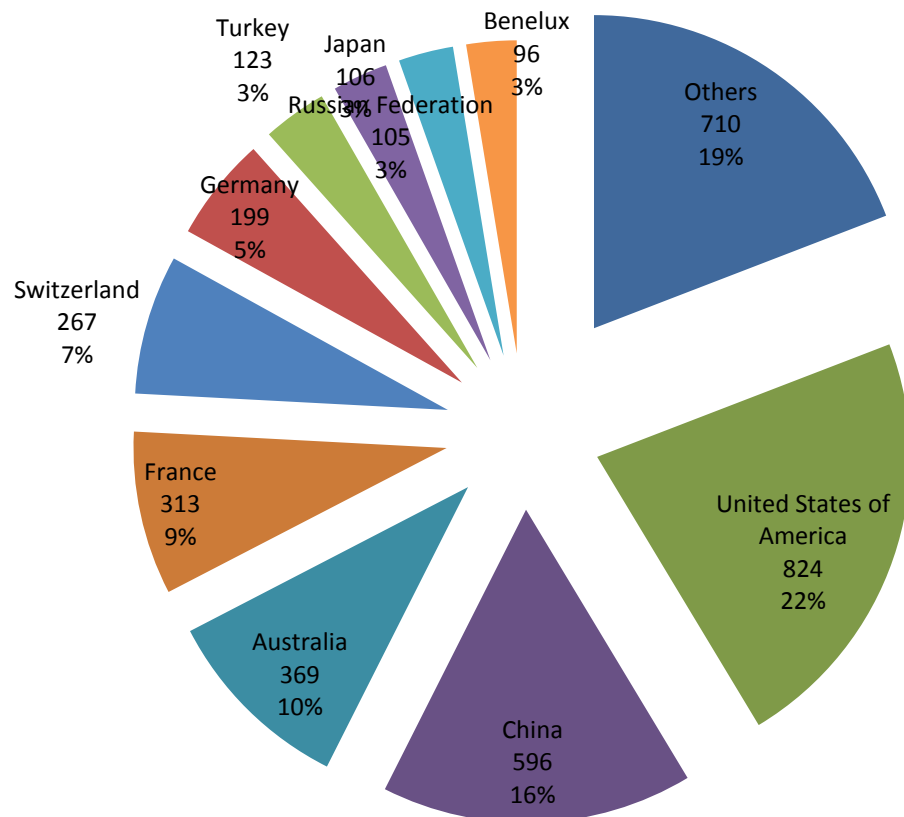

# Designations of United Kingdom by Country of Holder

Designations of United Kingdom in international registrations & subsequent designations by Country of Holder (2016)



# Madrid System Pendency Rates

- International applications – 51 days 
- Renewals – 54 days 
- Subsequent designations – 21 days 
- Decisions – 19 days
- Modifications – 47 days 
- Corrections – 180 days   

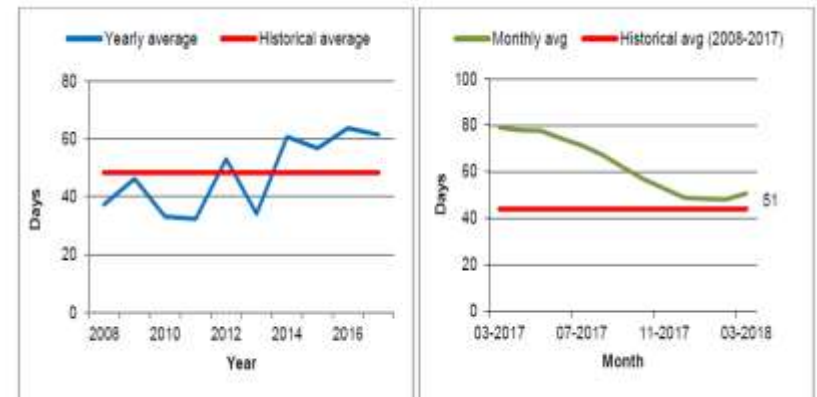

# Recent Developments

- Accession of Islamic Republic of Afghanistan
- Rule Changes in the Common Regulations
- Classification Guidelines
- WIPO Current Account
- [Madrid Monitor](#) – integrates [ROMARIN](#) (the [WIPO Gazette](#), [Madrid E-Alert](#) and [Real-time Status](#))
- [Member Profiles Database](#)
- [Contact Madrid](#) service (online form) – *Nov. 1, 2017*
- Madrid System webinars



# Legal Developments

## **Rules Changes in the Common Regulations – July 1, 2017**

- Introducing or changing the indication of the legal nature where the holder is a legal entity (Rule 25); new form [MM9](#) and fee of CHF 150

## **Rules Changes in the Common Regulations – November 1, 2017**

- Introducing a voluntary description of the mark in international applications and subsequent designations (Rule 9)
- Where an irregularity relating to MM18 form has not been remedied in a subsequent designation, WIPO will only abandon the designation of the US (Rule 24)

# Legal Developments

## **Rules Changes in the Common Regulations – November 1, 2017**

- Where the dCPs are not able to send communications directly to the IR holders, WIPO can forward them to the holders (new Rule 23bis)

## **Rules Changes in the Common Regulations – February 1, 2019**

- Introducing division of IRs before the dCPs and the possible later merger of divided IRs (new Rules 27bis and 27ter)

## **Working Group**

- Replacement, transformation and new types of marks to be discussed

# Classification Guidelines

- Purpose – to decrease irregularities
- Describes WIPO classification practices
- Divided into three sections:
  - General information – Nice Classification and Madrid
  - Classification principles applied by WIPO
  - Practical information on the acceptable format to list indications of goods and services



# WIPO Current Account Changes

- No minimum number of transactions
- Initial payment of CHF 2,000
- Minimum balance – notification sent to users if balance is less than CHF 200
- A form to open the account available on the website
- Email address required
- Account statement sent by email only

# E-Services

Search



File



Monitor



Manage



## Global Brand Database

- search existing marks from national & international sources
- trademarks, appellations of origin and official emblems

## Madrid Goods & Services Manager

- compile a list of approved goods & services terms in 18 languages

## Member Profiles Database

## Fee Calculator

## Madrid Monitor

- track real-time status of registration
- watch competitors' marks
- e-alerts
- consult the WIPO Gazette

## Madrid Portfolio Manager

- access documents
- request changes
- modify, designate & renew
- pay fees
- obtain extracts

# NEW – Contact Madrid



Single point of  
contact



Standardized input  
data

Mandatory fields  
Input fields allow better  
understanding of needs



Quick & automated  
distribution to  
relevant team  
Speedy processing  
of requests

# Contact Madrid: from November 2017



intreg.mail@wipo.int



WIPO contact us



madrid.team1@wipo.int



madrid.team2@wipo.int



madrid.team3@wipo.int



madrid.records@wipo.int



WIPO fax



Closed Nov 2017



Closed Dec 2017



Closed April 1, 2018



Contact Madrid

# Where to Access Contact Madrid

■ <http://www.wipo.int/madrid/en/#contact>

The screenshot shows the top navigation bar of the WIPO website. On the right side, there are links for 'Media', 'Meetings', 'Contact Us', 'My Account', and 'English'. The WIPO logo and 'WORLD INTELLECTUAL PROPERTY ORGANIZATION' are on the left. Below this is a secondary navigation bar with links for 'IP Services', 'Policy', 'Cooperation', 'Knowledge', 'About IP', and 'About WIPO'. A search bar labeled 'Search WIPO' is on the right. At the bottom of the header, there is a breadcrumb trail 'Home > IP Services > Madrid System' and a dropdown menu 'On this page'.

## Contacts

Madrid Customer Service opening hours: Monday - Friday, 9:00 a.m. to 6:00 p.m. (Geneva time).

### Enquiries / submitting forms

- [Contact Madrid](#)
- Tel: +41 22 338 86 86

### Extracts from the International Register

- [Contact Madrid](#)
- Tel: +41 22 338 8484



# Keep Updated on the Madrid System

- Visit the Madrid Website  
[www.wipo.int/madrid/en](http://www.wipo.int/madrid/en)
- Register to free  
[Madrid Webinars](#)
- Subscribe to [Madrid Notices](#),  
our legal and news updates
- Sign up for [Madrid Highlights](#)



**Thank you  
for your attention**

[matthew.forno@wipo.int](mailto:matthew.forno@wipo.int)

