

# Feedback from the Japan Patent Office After Some Two Years of Membership

Seminar on the Hague System for the International Registration  
of Industrial Designs: The Expansion Continues

Geneva

March 30, 2017

Daisuke KUBOTA

Director, Design Registration System Planning Office

Design Division, Japan Patent Office

# Contents:

1. Trends in International Applications Relating to Japan
2. Trends in Examination at the JPO
3. Important Points for the Designation of Japan in an International Design Application

References

1. Trends in International Applications Relating to Japan
2. Trends in Examination at the JPO
3. Important Points for the Designation of Japan in an International Design Application

References

- During the period from May 13, 2015 to December 31, 2016;
  - ✓ Number of international applications designating Japan: 1,698
  - ✓ Number of designs contained: 3,660
  
- International applications filed by European applicants accounted for 60% of the totality followed by the US (12%) and KR (12%).

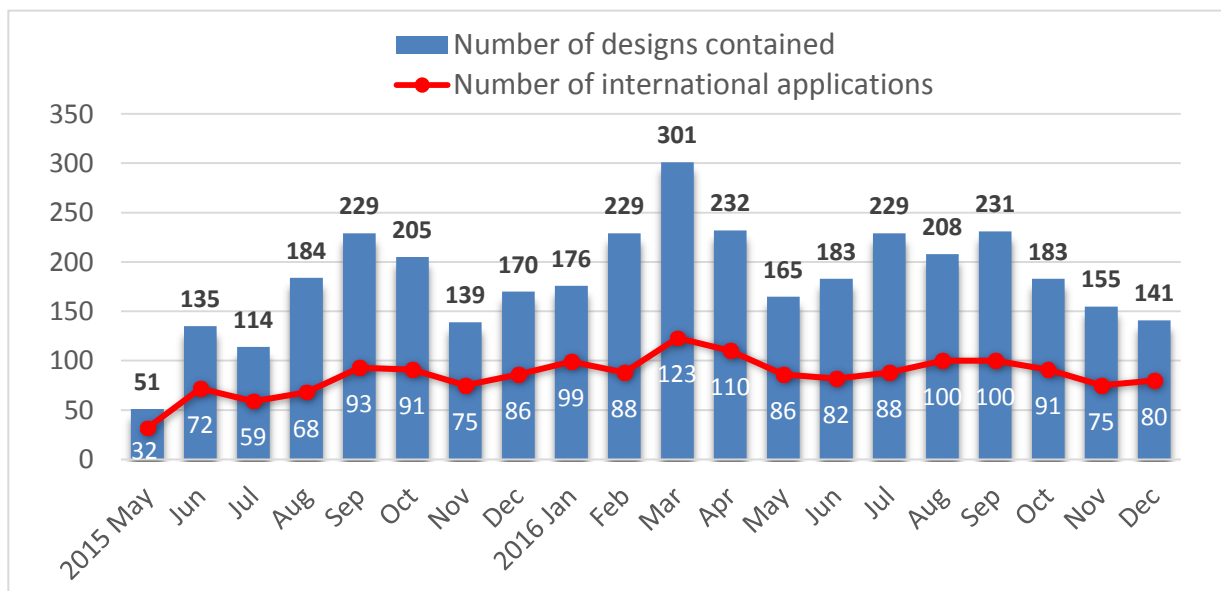

Source: WIPO statistics under the Hague System

Breakdown of applicant's Contracting Party

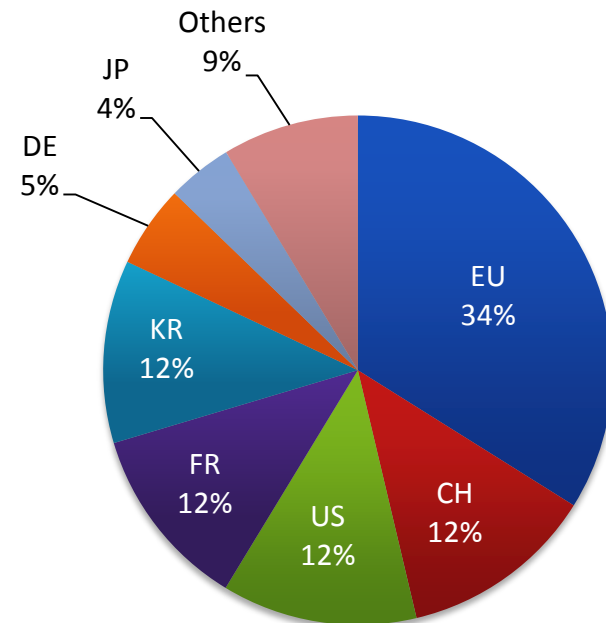

Source: WIPO The Hague Express

➤ 3 most popular Locarno Classes are:

- ✓ Class 14 Recording, Communication or Information Retrieval Equipment (10.7%)
- ✓ Class 12 Means of transport or hoisting (9.7%)
- ✓ Class 9 Packages and containers for the transport or handling of goods (9.0%)

Source: WIPO Hague Express

➤ In 2016, the international applications designating Japan pushed up the number of design applications filed by foreign applicants accounting for approximately 33% of the total foreign applications.

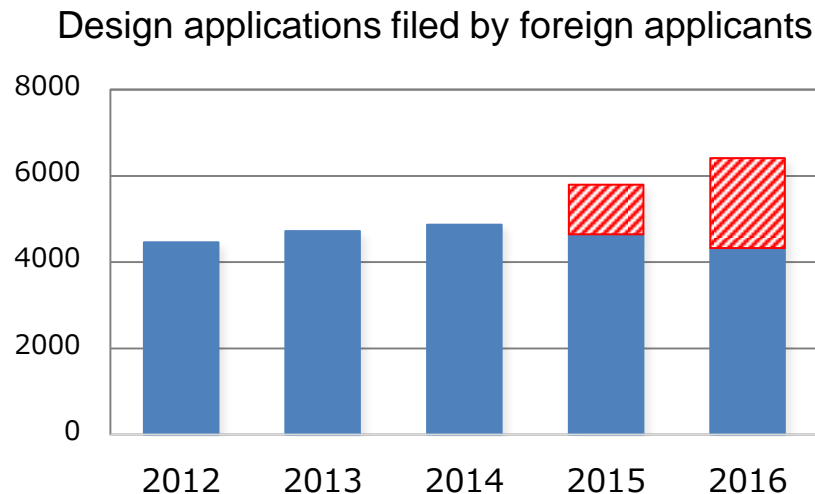

Source: JPO internal statistics

Breakdown of design applications filed by foreign applicants in 2016

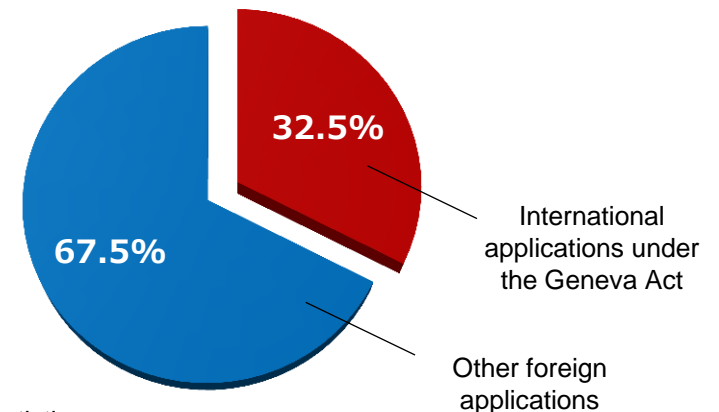

- During the period from May 13, 2015 to December 31, 2016;
  - ✓ Number of international applications filed by Japanese applicants: 476
  - ✓ Number of designs contained: 1,251
  - ✓ Number of indirect filing: 44 (69 designs)
- The Hague System has been gradually coming into wide use among Japanese applicants.

Source: JPO internal statistics

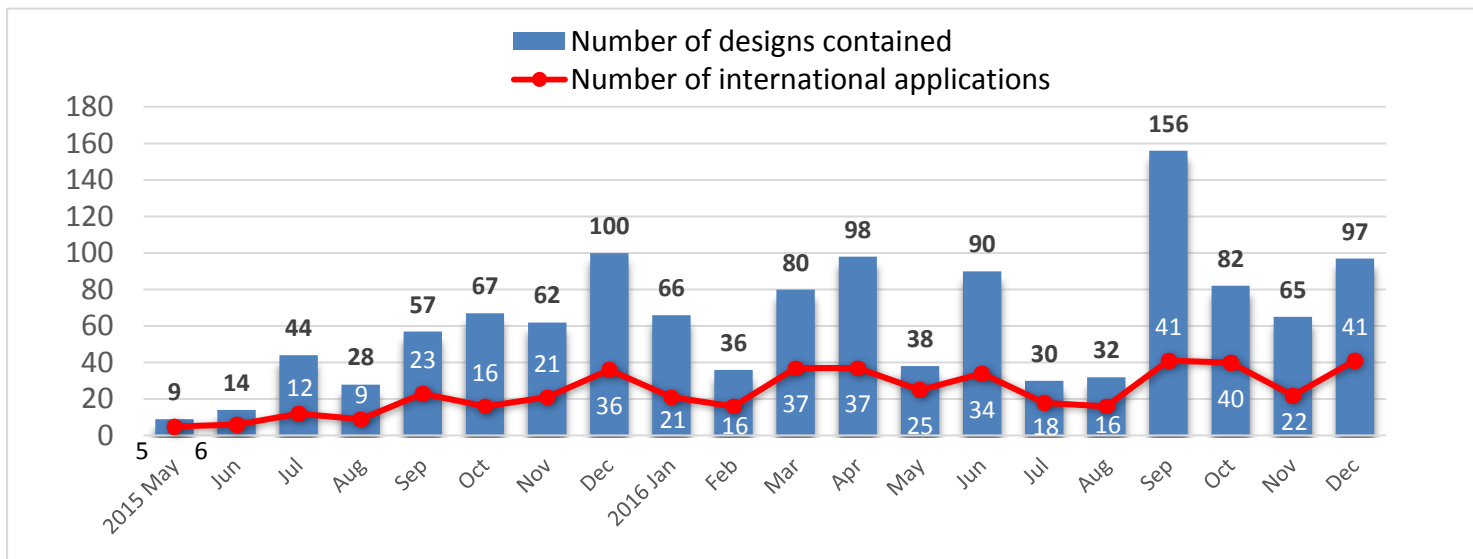

Source: WIPO statistics under the Hague System

1. Trends in International Applications Relating to Japan
- 2. Trends in Examination at the JPO**
3. Important Points for the Designation of Japan in an International Design Application

References

Main subject matters of examination	Criteria for examination						
Conditions for design registration (Article 3 of the Design Act)	<table border="1"> <tr> <td data-bbox="267 358 779 489">Industrial applicability</td> <td data-bbox="779 358 1978 489">Whether the design is industrially applicable. (Whether the design is specific in both “article” and “appearance”.)</td> </tr> <tr> <td data-bbox="267 489 779 644">Novelty (incl. similarity)</td> <td data-bbox="779 489 1978 644">Whether the design is new. (Whether the design is identical with or similar to a publicly known design.)</td> </tr> <tr> <td data-bbox="267 644 779 768">Creativity</td> <td data-bbox="779 644 1978 768">Whether the design is one that could be easily created by a person ordinarily skilled in the art of the design.</td> </tr> </table>	Industrial applicability	Whether the design is industrially applicable. (Whether the design is specific in both “article” and “appearance”.)	Novelty (incl. similarity)	Whether the design is new. (Whether the design is identical with or similar to a publicly known design.)	Creativity	Whether the design is one that could be easily created by a person ordinarily skilled in the art of the design.
Industrial applicability	Whether the design is industrially applicable. (Whether the design is specific in both “article” and “appearance”.)						
Novelty (incl. similarity)	Whether the design is new. (Whether the design is identical with or similar to a publicly known design.)						
Creativity	Whether the design is one that could be easily created by a person ordinarily skilled in the art of the design.						
Conditions for design registration (Article 3bis)	Whether the design is identical with or similar to a part of a design in a prior application.						
Unregistrable designs (Article 5)	Whether the design is eligible for protection in consideration of public interest, etc.						
One application per design (Article 7)	Whether only one design based on an appropriate article is claimed in one application.						
Prior application (First-to-file rule) (Article 9)	Whether the design application was filed at the earliest among those containing same or similar designs.						
Related designs (Exception to the first-to-file rule) (Article 10)	Whether the design is similar to only the other design (principal design) which was selected from the applicant's own designs filed on the same date or earlier.						



- During the period from May 13, 2015 to September 30, 2016;
  - ✓ Number of grants (statement of grant of protection): 204
  - ✓ Number of refusals (notification of refusal): 627
  - ✓ Average office action period: 6.9 months
- “Industrial applicability” and “novelty” are two major grounds for refusal.

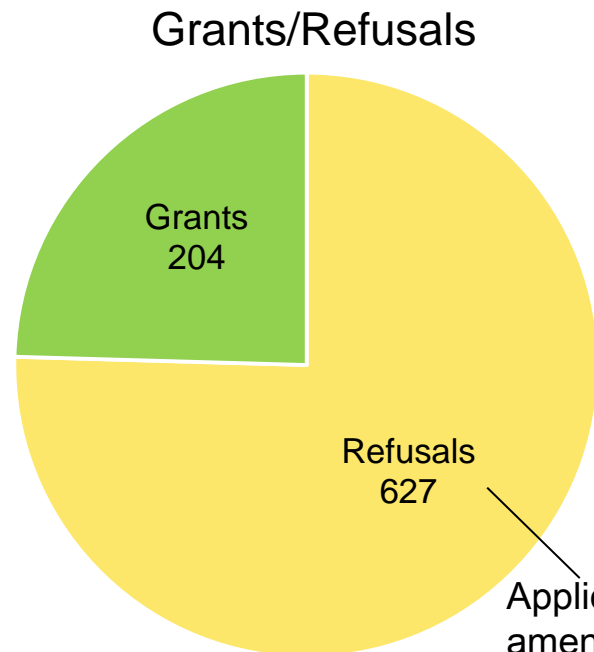

Applicant can submit opinions and amendments (if needed) against to a notice of refusal to the JPO

### Breakdown of the refusals by ground

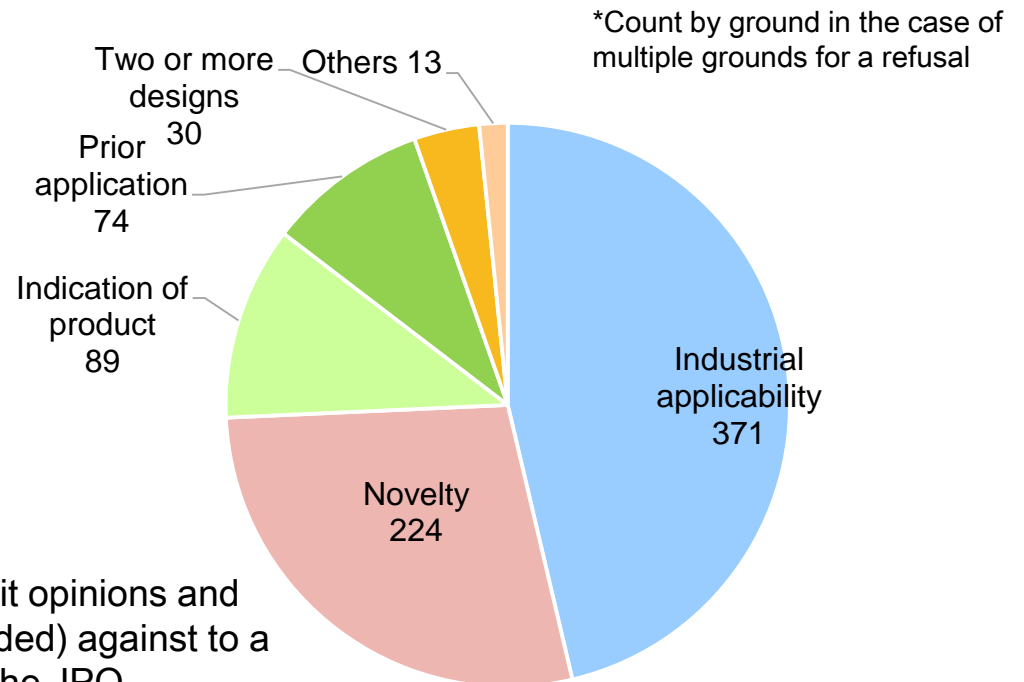

## (1) Industrial applicability (Whether the design is concrete)

It is not clear whether it is an application for a partial design or not because although the drawing uses solid lines and broken lines to indicate the design, any statement about the part for which design registration is sought is not included in the “Description”.

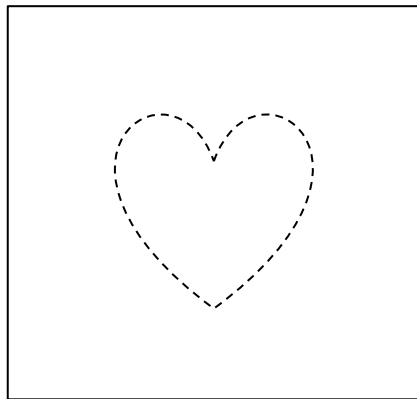

[Indication of product] Handkerchief  
[Description]

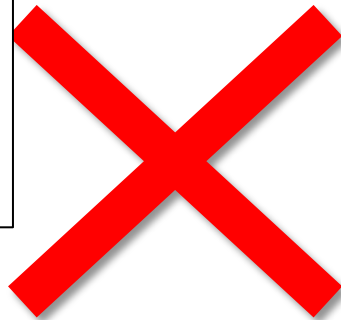

## (1) Industrial applicability (Whether the design is concrete)

**The design is not concrete** since the number of drawings is insufficient.

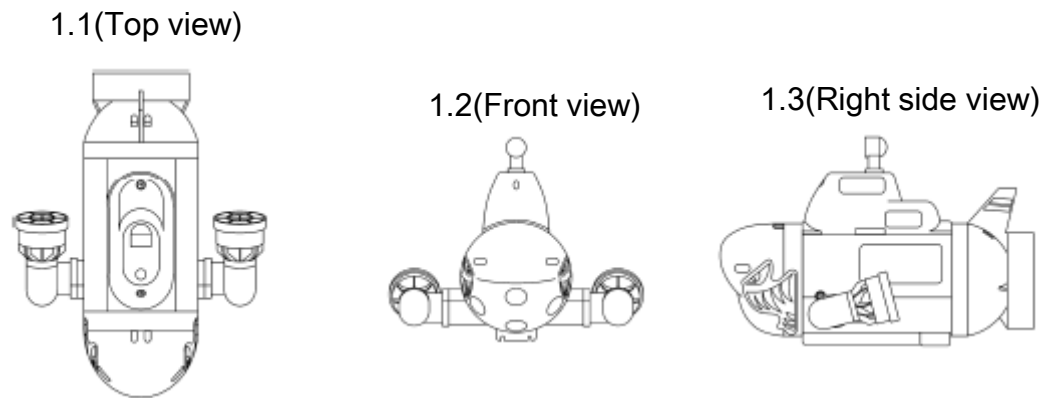

(Source of image) Handbook for the Statement in the Application and Drawings for Design Registration

In the above case, a bottom view, a left side view and a back view are needed for the design to be concrete.

## (2) Indication of product

A name of an article stated in “Indication of product” shows a **broader concept** than a classification of article as provided by the Japanese national ordinance.

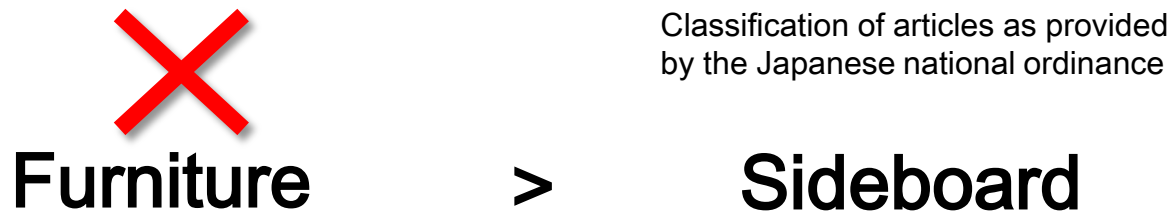

### > Japanese Design Act (Article 7)

An application for design registration shall be filed for each design in accordance with a classification of articles as provided by an Ordinance of the Ministry of Economy, Trade and Industry.

### > Classification of articles (the Ordinance for Enforcement of the Design Act)

## (2) Indication of product

A name of an article stated in “Indication of product” is the **name of the part for which design registration is sought.**

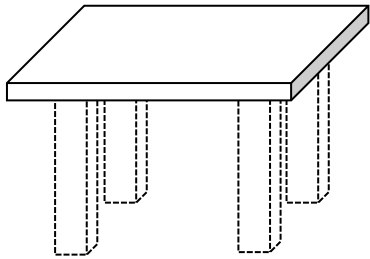

**Part of table**

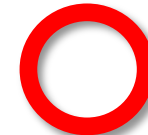

**Table**

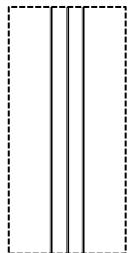

**Tire tread**

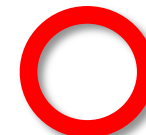

**Tire for automobile**

1. Trends in International Applications Relating to Japan
2. Trends in Examination at the JPO
- 3. Important Points for the Designation of Japan in an International Design Application**

References

## ➤ “Design” is an appearance of a tradeable article.

Article 2(1) of the Japan’s Design Act (Definition of “Design”)

“Design” in this Act shall mean the shape, patterns or colors, or any combination thereof, of an article (including a part of an article...), which creates an aesthetic impression through the eye.



- **Registrable design must be specific in both “article” and “appearance” in the application.**

[Reason 1]

- ✓ Design right is an exclusive right to commercially work the article to the design.
- ✓ Effects of a design right covers the registered design and similar designs thereto.

Article 23 (Effect of design right)

A holder of a design right shall have the exclusive right to work the registered design and designs similar thereto as a business; provided, however, that where an exclusive license regarding the design right is granted to a licensee, this shall not apply to the extent that the exclusive licensee is licensed to exclusively work the registered design and designs similar thereto.

Article 2(3) (Definition of “Work”)

“Work” of a design in this Act shall mean the manufacturing, using, assigning, leasing, exporting or importing, or offering for assignment or lease (including displaying for the purpose of assignment or lease...) of an article to the design.

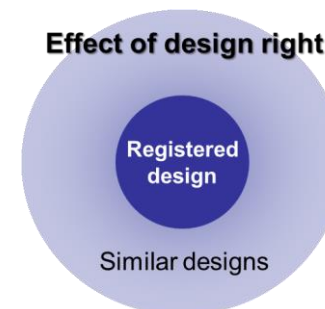
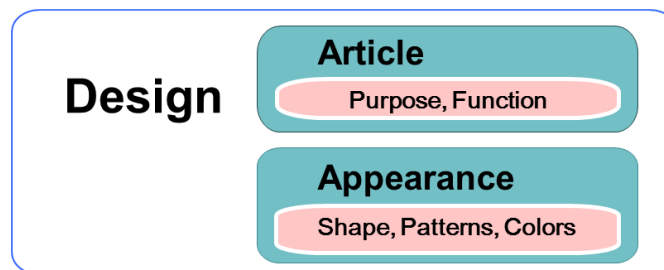



## [Reason 2]

- ✓ “Article” and “appearance” must be determined based on the design described in the application and represented in the drawing.
- ✓ Similarity judgement must be done based on the aesthetic impression of the consumers of the designs concerned (including traders).
- ✓ Two designs are determined similar when both “article” and “appearance” are similar to each other. (Supreme court decision)

## Article 24 (Scope of registered design, etc.)

(1) The scope of a registered design shall be determined based upon the design stated in the application and depicted in the drawing or represented in the, photograph, model or specimen attached to the application.

(2) Whether a registered design is identical with or similar to another design shall be determined based upon the aesthetic impression that the designs would create through the eye of their consumers.

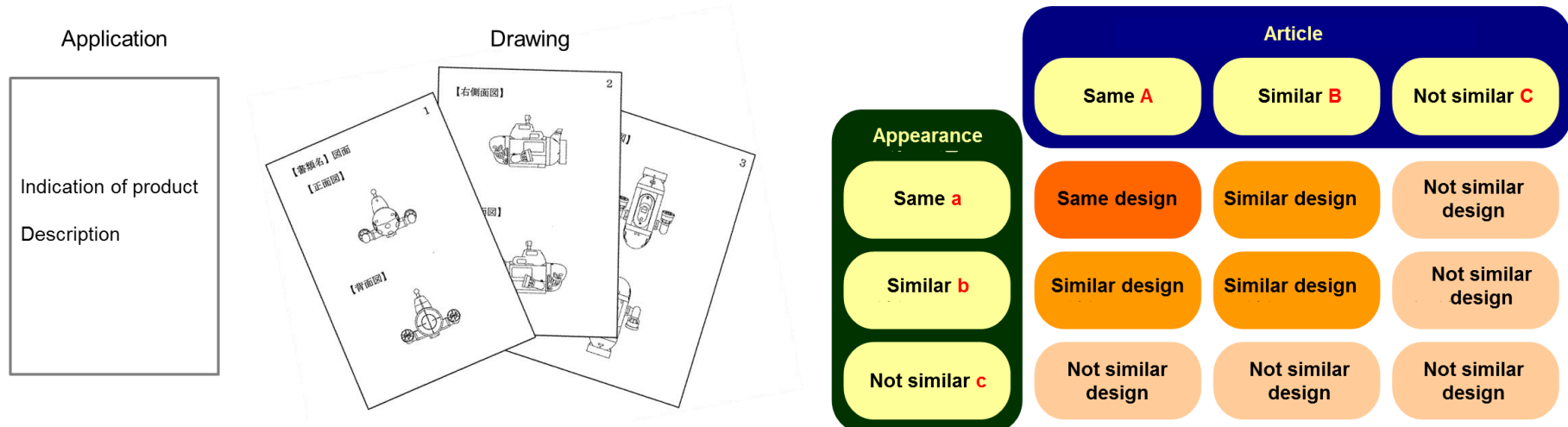

- **Granting protection to an ambiguous design in terms of “article” or “appearance” may bring the right holder a risk of possible invalidation and even have a bad influence on a third party in assessing the scope of a registered design.**
- **When an international design application designating Japan has been registered and published, it is deemed as an application for design registration in Japan and, accordingly, it will be treated in the same way as a national application.**
- **JPO examines design applications with a view to establish a distinct and stable design right.**

**[Point 1] Scope of “Design” under the Japanese Law**

**[Point 2] Submission of a certified priority document**

**[Point 3] Reproduction (Drawing)**

**[Point 4] Description**

**[Point 5] Disclaimer**

**[Point 6] Indication of product**

- Products which do not constitute an article are **NOT** to become the subject of design protection in Japan. Such products are typically those belong to class 32 of the Locarno Classification (e.g. surface pattern, logo, ornamentation, etc.), Icons and GUIs (graphical user interfaces).

## Inappropriate examples



Surface pattern



Logo



Icon / GUI



Typeface

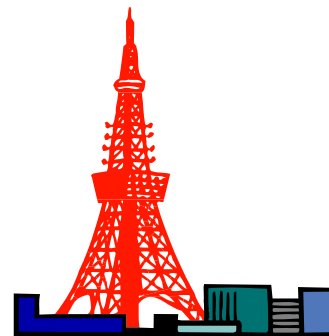

Immovable property (Building, etc.)

# [Point 1] Scope of “Design” under the Japanese law



[Indication of product]  
**Graphic symbol**



[Indication of product]  
**T-shirt**

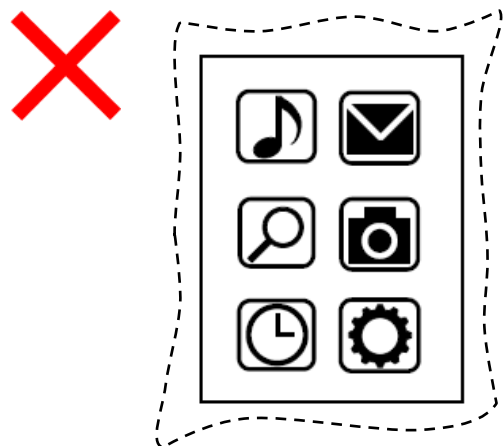

[Indication of product]  
**Graphical user interface for a display screen**

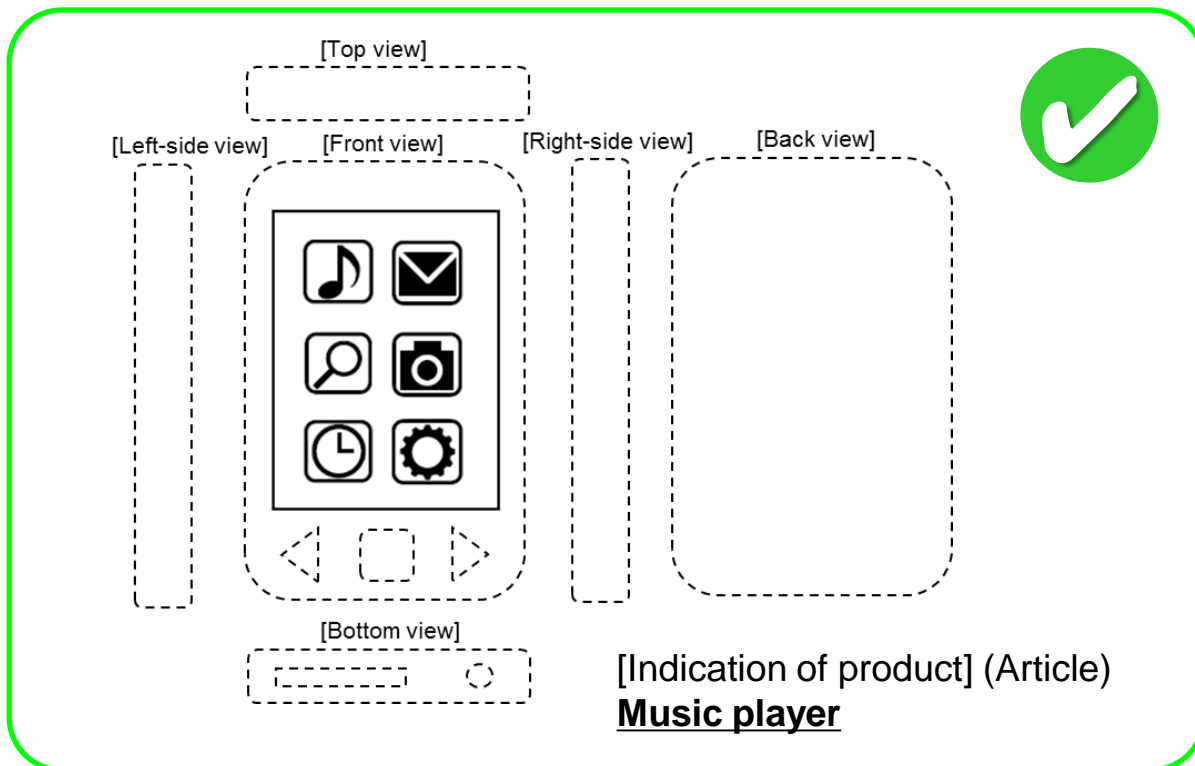

[Indication of product] (Article)  
**Music player**

- Priority right under the Paris Convention relates to the benefit of not only the applicant concerned but also other interested parties (including competitors).
- For instance, first-to-file rule, as well as novelty requirement, is one of the important subject matters of examination in Japan. In the process of the examination, it is necessary to determine as to validity of the priority claim, since priority date would serve as the base date for making judgement on these requirements.
- In addition to the shape and patterns, actual colors and/or tones are also essential elements for representing a design. All these elements must be presented without lack/omission and with a certificate from the Office of the first filing for reliability.  
(Necessity of the submission of an original certified priority document)

## 1. Claiming priority

- Priority claim must be made at the time of filing an international application by entering adequate information in the application form (DM/1) or on the E-Filing interface.

## 2. Submission of a certified priority document to the JPO

- Where a priority claim was made in the international application, an original copy of the certified priority document must be submitted to the JPO within three months from the date of publication of the international registration.
- “Overseas resident” has to undertake this procedure through a local representative in Japan.
- If a certified priority document is not submitted, or is submitted after the above period, the right of priority will be lost. **Please be careful!**

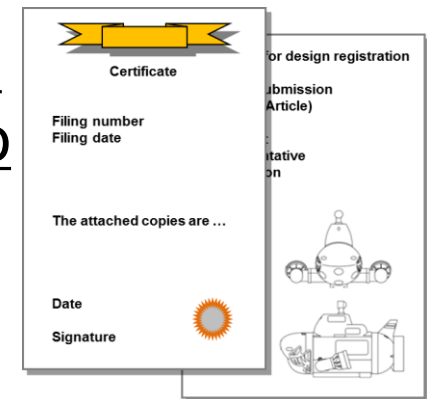

- **Never fail to submit a certified priority document to the JPO where priority claim was made.**
- **There may be other possible ways:**
  - ✓ To file an international application as first filing with the designation of Japan. (No need to claim priority.)
  - ✓ To control publication timing of the first filed design.

Making good use of the deferment of publication system for the first filing (e.g. EU, Germany) helps to keep the design unpublished for a certain period. By filing a following international application designating Japan during this deferment period, you may eliminate, at least, the situation where publication of the first filed design disturbs novelty of the second filed design regardless of the effects of the priority claim.

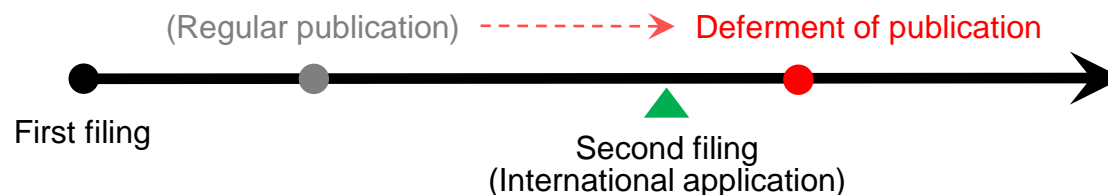



- Japan has made the following declaration under Rule 9(3) of the Common Regulations concerning “specific views required”.

“Where the product which constitutes the industrial design is three-dimensional, a front view, a back view, a top view, a bottom view, a left side view and a right side view each made in compliance with the method of orthographic projection are required.”

### **Remember!**

- **Registrable design must be specific in both “article” and “appearance” in the application.**
- **Accuracy of these two elements is indispensable to proper understanding of the design and adequate comparison with another design.**

- Reproductions for a three-dimensional product
  - ✓ Six views (a front view, a back view, a top view, a bottom view, a left side view and a right side view) (See [Point 4] for possible omission)
  - ✓ Method of orthographic projection
  - ✓ Same scale (recommended)
  - ✓ Legend for each view (e.g. “top”, “bottom”, ”perspective”, etc.)

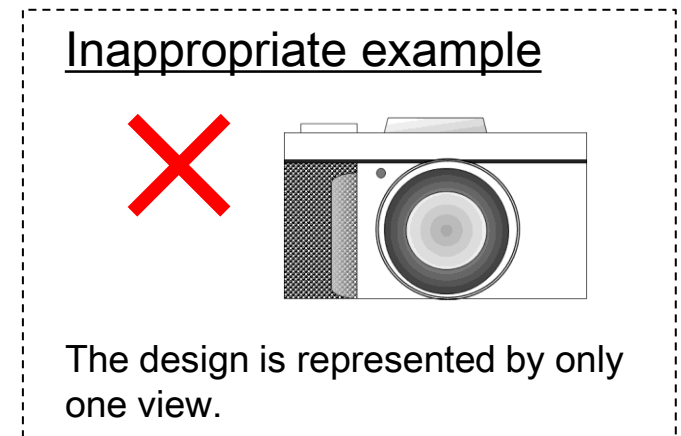
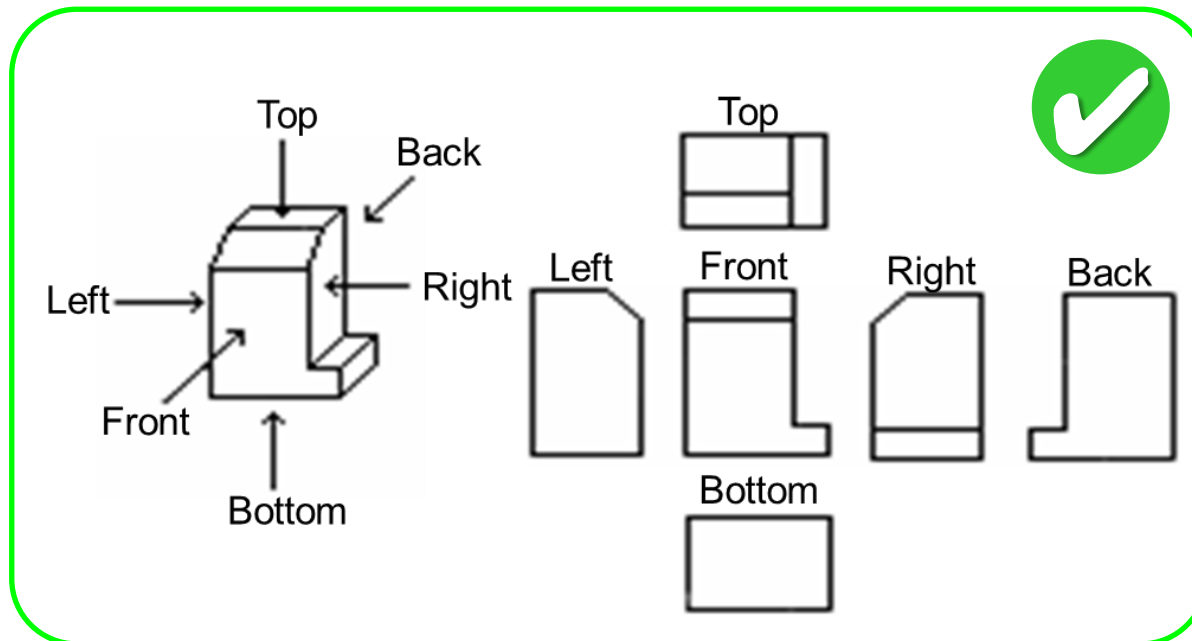

# [Point 3] Reproduction (Drawing)

- Ambiguity in appearance must be avoided.
  - ✓ Even with six views, there might be possibilities of two or more different shapes.

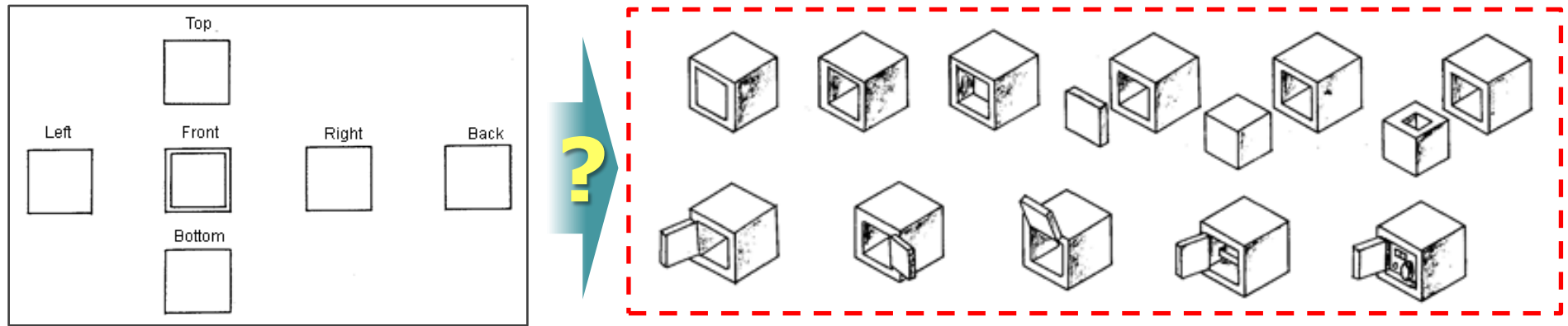

- Depending on the actual shape, additional view(s) are necessary to fully disclose the design.

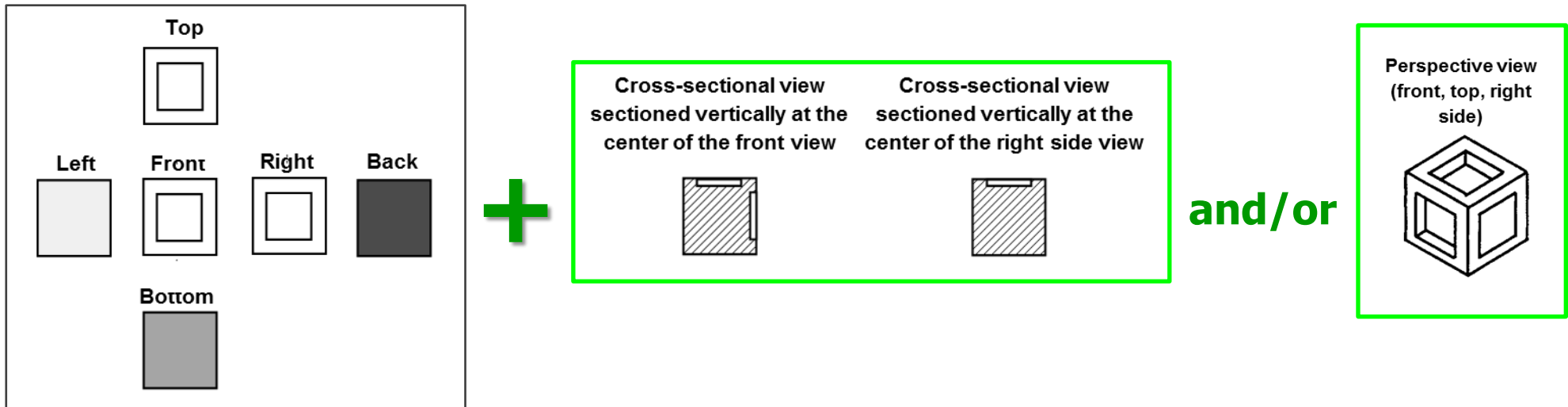

## [Point 3] Reproduction (Drawing)

- Reproductions must be made in compliance with the orthographic projection method.
  - ✓ For proper understanding of the characteristic feature(s) e.g. proportion between length and breadth, actual shape of a characteristic part, position of a pattern, etc.
  - ✓ Perspective views from random directions might not accurately represent the design.

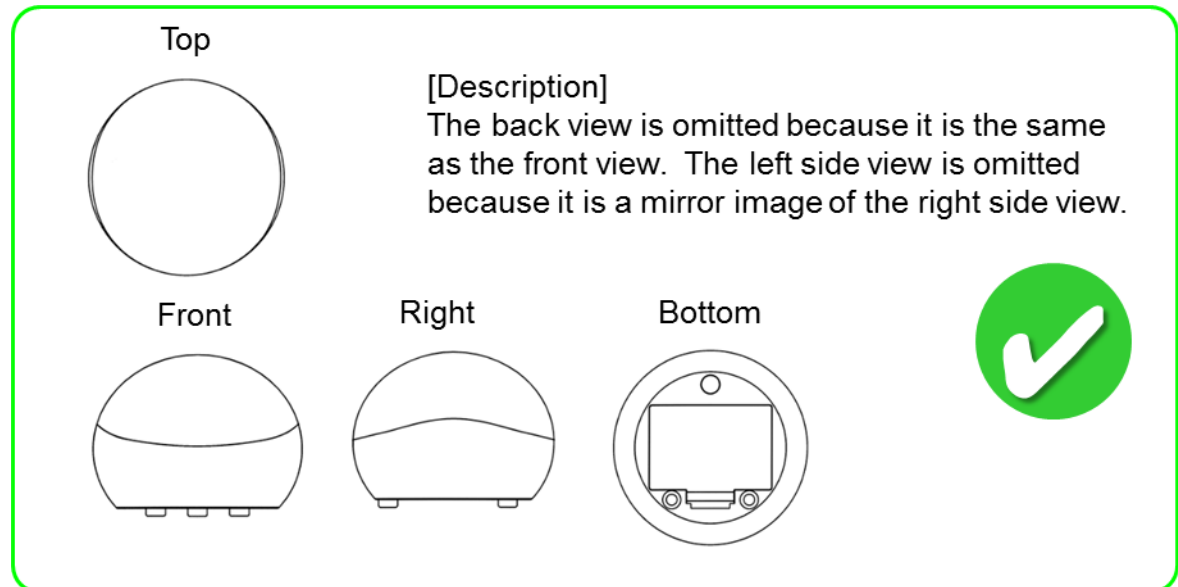
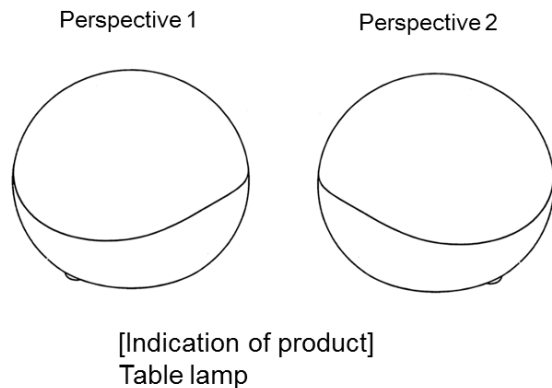

- In the following cases, a certain view may be omitted in exchange for a proper explanation in the description.
  - ✓ Where one view and another view\* are identical or mirror image: Either view
    - \* Front view and back view, top view and bottom view, right side view and left side view
  - ✓ For 2D products, where back view has no ornamentation: Back view
  - ✓ For large-sized or heavy product whose bottom is normally not seen (e.g. large machine, large vehicle), where the design can be understood accurately: Bottom view

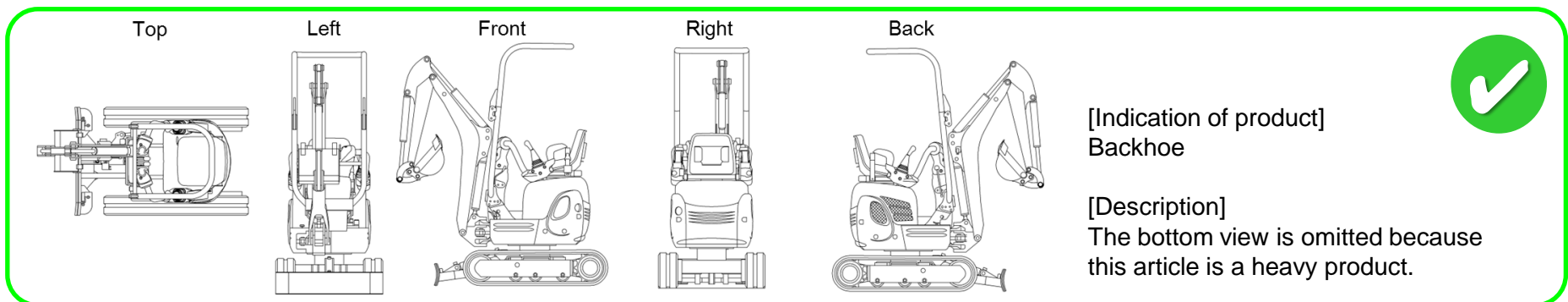

- Shading, dots, or parallel thin lines may be provided in the representations to represent relief or contours of surfaces of a three-dimensional product.
- In these cases, the purpose of these expressions must be clearly stated in the description in order to avoid any confusion with patterns and/or colors on the surfaces.

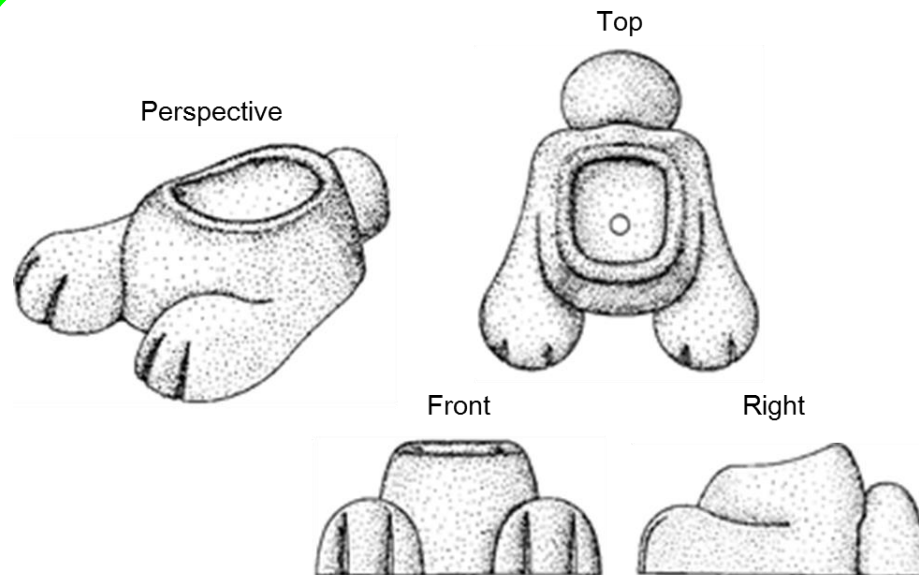

[Description]

The dots in the representation represent contours only and do not illustrate an ornamentation or decoration on the surface of the product.

JPO will begin to apply the revised design examination guideline on description as of April 1, 2017.

(1) When it is determined that the lines, points, etc. (shades) are clearly for specifying the shape, omission of explanation of the lines, points, etc. will be accepted.

## Examples in which omission of explanation is accepted

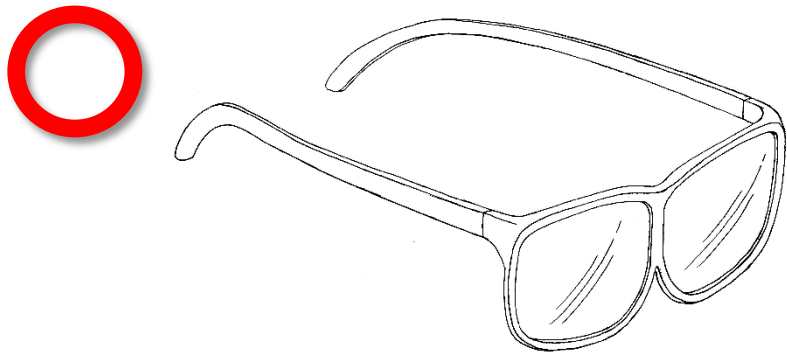

Judging from the features of the article of “glasses,” it is not common to put a linear pattern in the middle part of the lens.

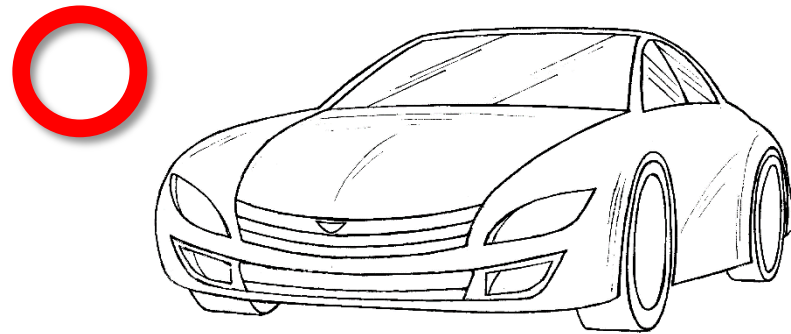

Judging from the features of the article of a “passenger car,” it is not common to put a linear pattern on the auto body or windows.

(2) For views having brightness difference and being created using CG, when it is obvious that the brightness difference represents “shades,” the explanation of the fact can be omitted in the same treatment that has applied for photographs.

Example of views in which it is **obvious** that the brightness difference is “shades” even without an explanation

Article to the Design:  
“Medical Image Photographing Apparatus”

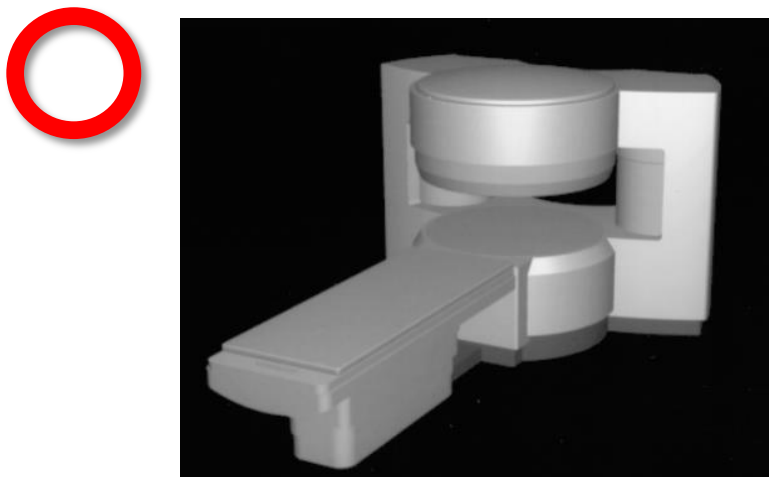

Example of views in which it is **unclear** whether the brightness difference is “shades” or not without an explanation

Article to the Design: “Eraser”

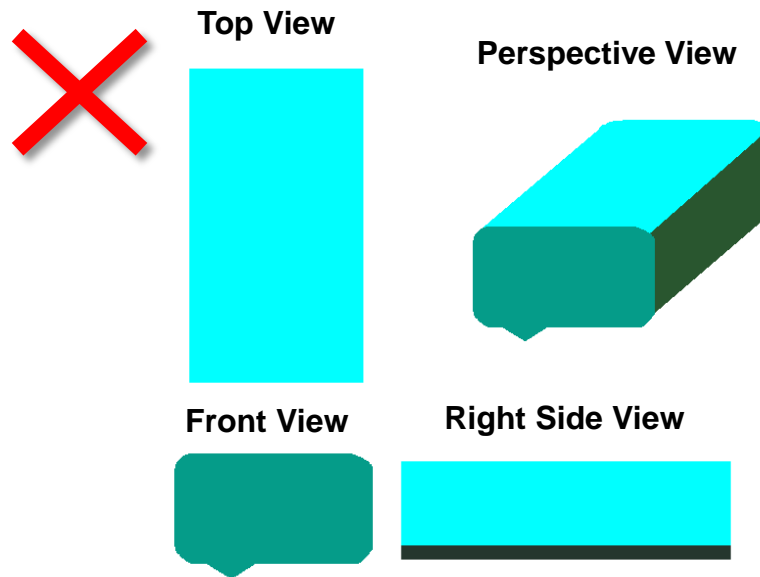



(3) There are cases where it is accepted to omit the explanation for coloration of the background for views created using CG, when it is determined that the colored part is obviously the background.

Examples of views in which it is **obvious** that the shading is coloration of the background even without an explanation

Article to the Design: “Mouse for Computer”

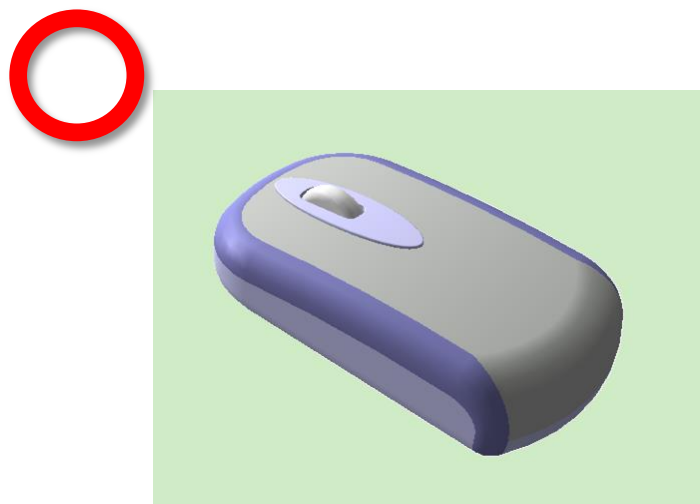

Example of views in which it is **unclear** whether the shading is coloration of the background or not without an explanation

Article to the Design: “Ornamental Sticker”

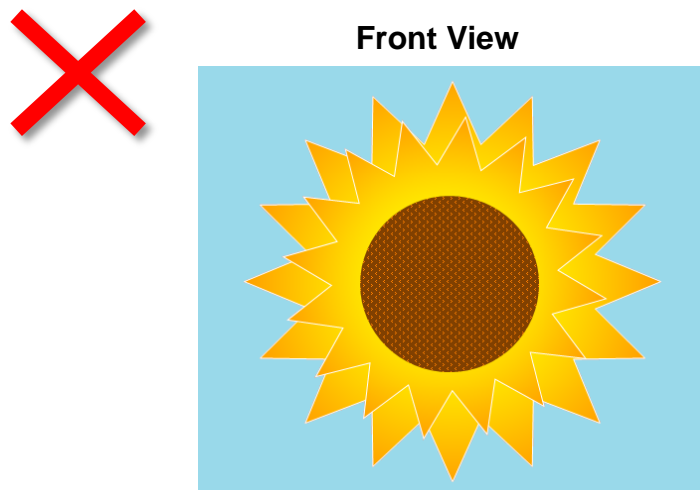

## [Point 5] Disclaimer

- A design with an expression of disclaimer may be understood as a “partial design” in Japan.
- Where protection is sought for a “partial design” (design of a part of an article),
  - ✓ Show the appearance of the whole article in the drawing,
  - ✓ Make clear distinction between claimed part and disclaimed part by means of e.g. solid lines and broken lines, and
  - ✓ Explain to that effect in the description.

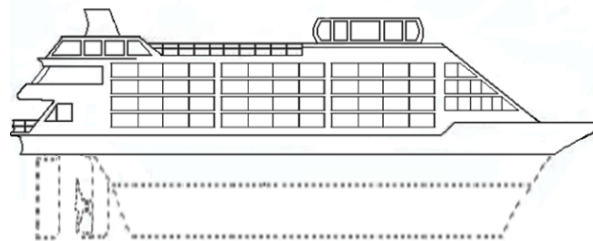
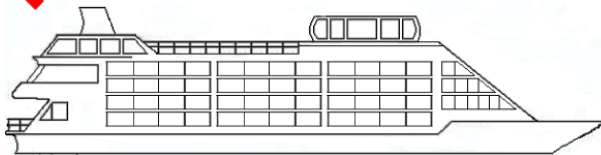

[Indication of product]  
Ship

[Description]  
No protection is sought for the features  
of the design indicated by broken lines.

# [Point 5] Disclaimer

- Partial design protection would be more effective for the elimination of sly imitations.

Design right (Whole design)

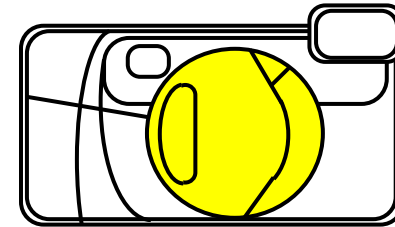
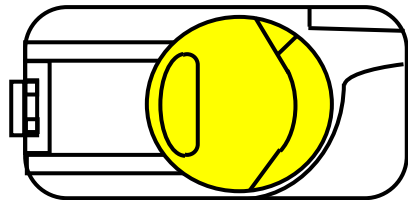

Design right (Partial design)

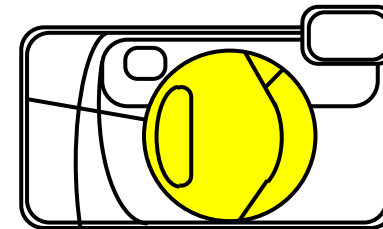
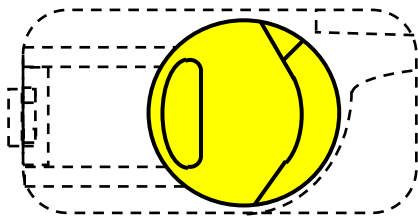

Design right (Partial design)



- Both “final product” and “component part” are equivalent to an article, which is tradeable on the market.
- “Partial design” (design of a part of an article) is different from “design of a component part” (design of a whole article).

**Design of a whole article**



[Indication of product]  
Passenger car

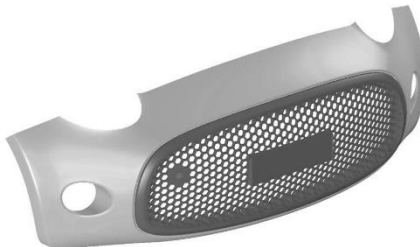

[Indication of product]  
Front bumper for automobiles

**Design of a part of an article**

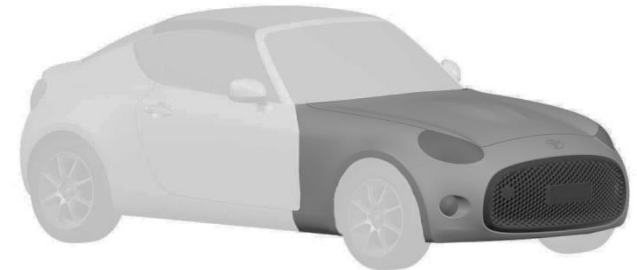

[Indication of product]  
Passenger car

### Remember!

- Registrable design must be specific in both “article” and “appearance” in the application.
- Accuracy of these two elements is indispensable to proper understanding of the design and adequate comparison with another design.

- **Acceptance of an international registration containing multiple designs**
- **Exception to lack of novelty**
- **Indication of the principal design (Related designs)**
- **Identity of the creator**
- **Response to the notification of refusal**
- **Rules of procedures undertaken to the JPO**

## ■ Acceptance of an int. registration containing multiple designs

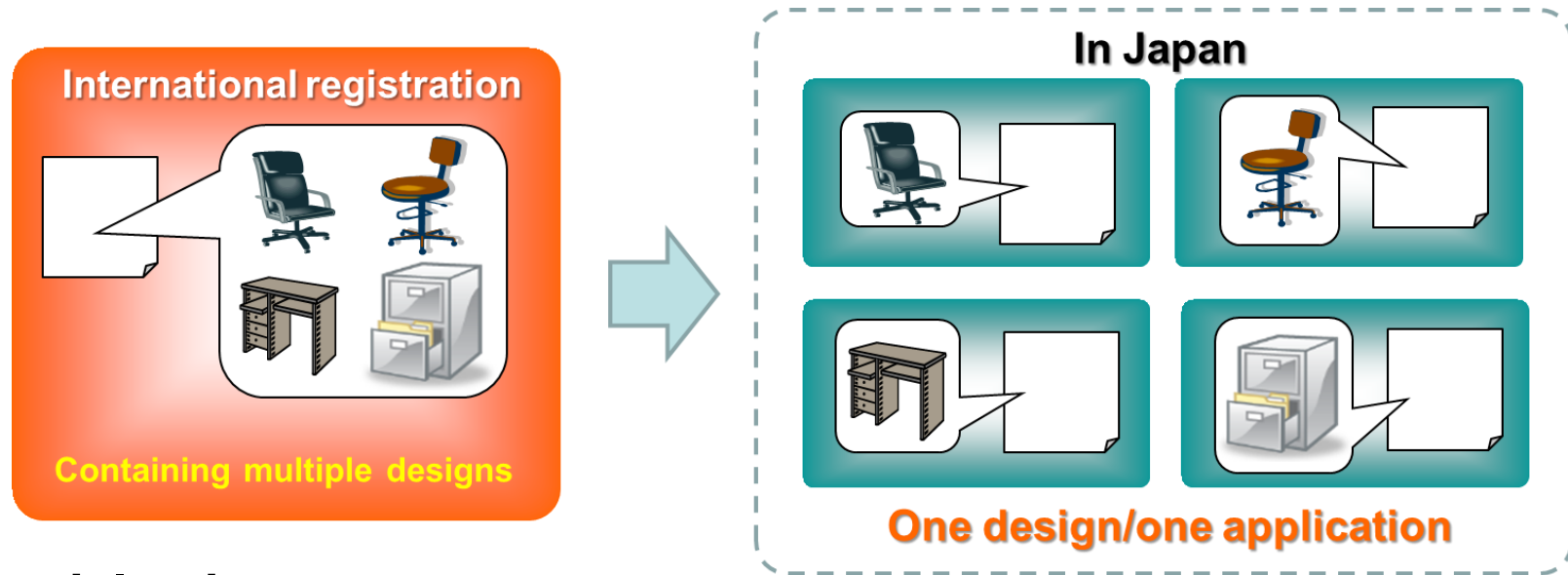

### Essential points

- ✓ In accordance with the provision of the Japan's Design Act, an international registration containing two or more designs will be treated as two or more domestic applications those filed for each design contained in the international registration (there is no need for the holder to divide the international registration).
- ✓ Consequently, any procedure before the JPO must be undertaken by not for the international registration as a whole but for each design contained in the international registration.

## ■ Exception to lack of novelty

### 1. Declaration

- Declaration is necessary for claiming exception to lack of novelty.
- Declaration may be made either in the international application or by submitting a relevant document to the JPO within 30 days from the date of publication of the international registration.

### 2. Submission of a certificate to the JPO

- Where declaration was made, a certificate must be submitted directly to the JPO within 30 days from the date of publication of the international registration.
- “Overseas resident” has to undertake this procedure through a local representative in Japan.

Any design disclosed by the creator or applicant during the period of 6 months preceding the date of the international registration would become the subject of this exception, while any disclosure in a gazette is excluded. (Article 4(2) of the Japan’s Design Act)

## ■ Indication of the principal design (Related designs)

- Where a design which is the subject of an application\* is similar to the design in another application\* filed on the same date or earlier\*\* (called “principal design”), and where both applications are filed by the same applicant, the former design may be registered as a related design in relation to the principal design.

\* Only national application including an international registration designating Japan

\*\* An application for a related design must be filed on or after the filing date of the principal design and before the date of its publication in the design bulletin

- This system is designed for better protection of variation designs and is the exception to the first-to-file rule.

Expansion and clarification of the scope of design right

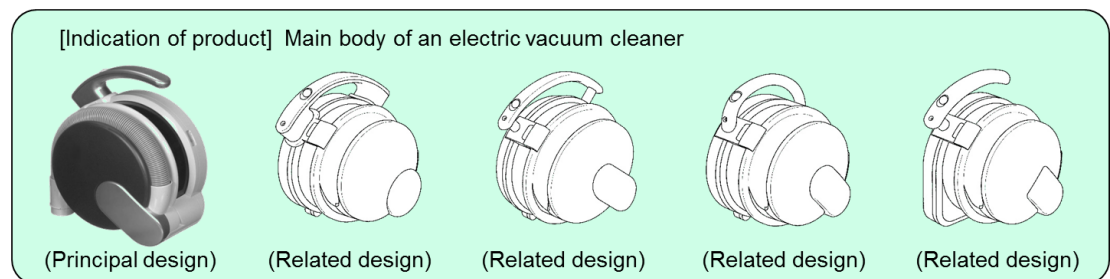
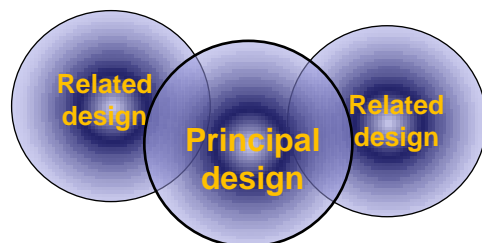



## ■ Identity of the creator

- As the Japan's Design Act requires information on the creator of a design, always fill in relevant information regarding creator.

DM/1

**11** IDENTITY OF THE CREATOR<sup>7</sup>  
If no industrial design is indicated, it will be understood that the identity of the creator relates to all industrial designs included in the present application.

No. of the design (in numerical order)	Creator's full name	Address	Postal code	City	Country

If the space provided is not sufficient, check this box and use a continuation sheet.

<sup>7</sup> If Bulgaria, Finland, Ghana, Hungary, Iceland, **Japan**, Norway, Republic of Korea, Romania, Serbia, Tajikistan or the United States of America is designated in item 7, this information is necessary (refer to the Guide, "Identity of the creator").

E-filing interface for international application

**Information concerning the creator(s)**

**Name and address**

Name \*

Address \*

Zip/Post code

Town\*

Country\*

Design(s)

(\*) Compulsory field

**Declaration of inventorship**

Attach an existing declaration (pdf)  Make a new declaration

## ■ Response to the notification of refusal

- As a response to the notification of refusal issued by the JPO, the holder of the international registration may submit a written opinion or an amendment to the JPO.
- Time limits for responding to the notification of refusal are;
  - ✓ For holders not having residence, domicile or establishment in Japan (“overseas resident”):  
Three months from the date of dispatch of the notification by the JPO (extendable for one month).
  - ✓ For holders having residence, domicile or establishment in Japan:  
Sixty (60) days from the date of dispatch of the notification by the JPO.

### ■ Rules of procedures undertaken to the JPO

- “Overseas resident” must undertake procedures to the JPO through a representative who is domiciled or resident in Japan.
- Any documentation addressed to the JPO must be submitted after the publication of the international registration concerned.
- Procedures undertaken to the JPO deriving from an international registration must be done by a written document.

1. Trends in International Applications Relating to Japan
2. Trends in Examination at the JPO
3. Important Points for the Designation of Japan in an International Design Application

## References

- **National procedures after the international publication**
- **Duration of design rights**
- **Individual designation fee**
- **Request for refund of the individual designation fee**
- **Declarations**

# National procedures after the international publication

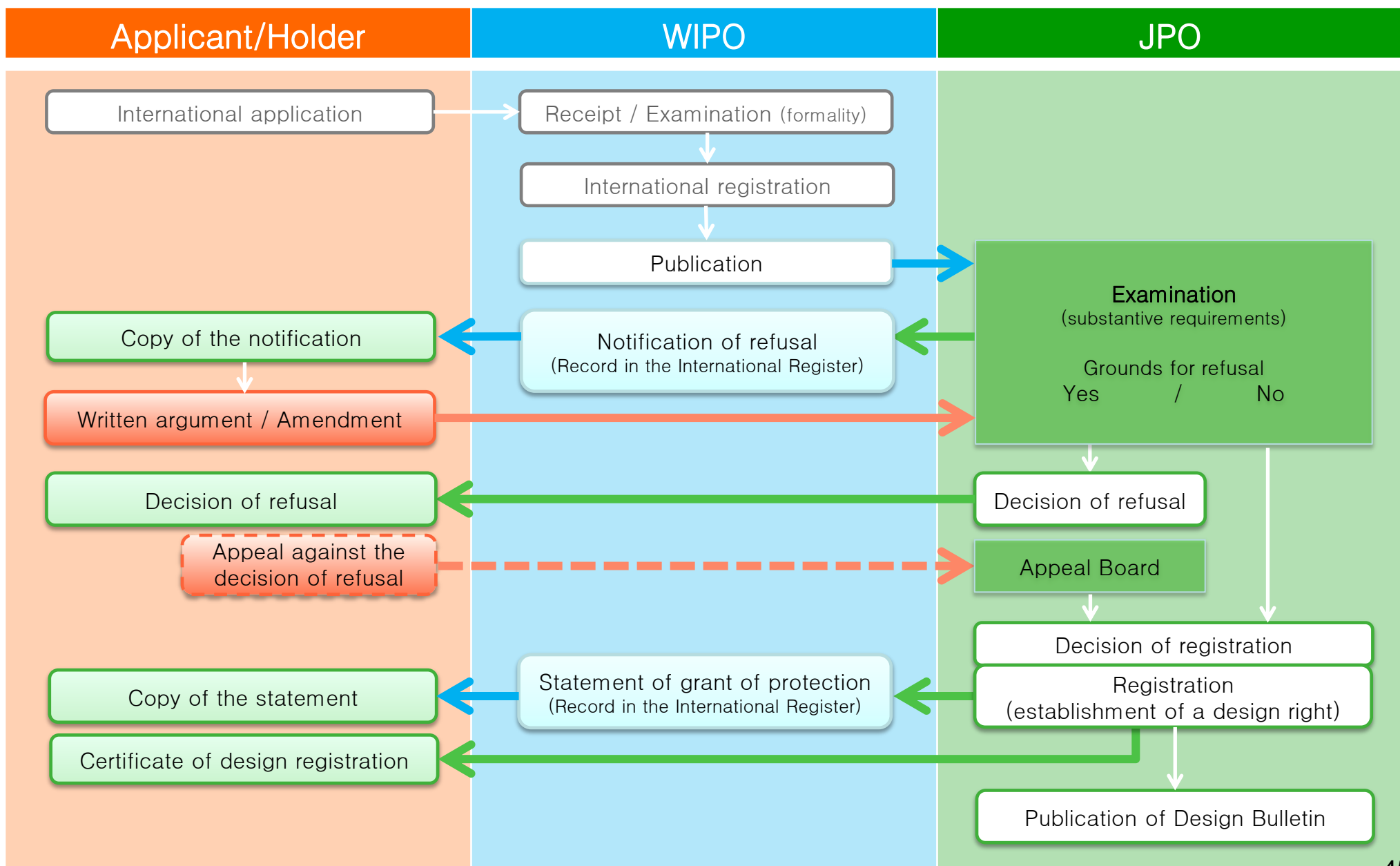

- The maximum duration of a design right in Japan is 20 years from the date of the registration of the establishment of a design right in Japan (not from the date of the international registration).
- With regard to the design contained in an international registration, upon registration establishing a design right in Japan, the holder may also claim compensation against a person who has worked the design or designs similar thereto as a business after the publication of the international registration and prior to the registration establishing a design right in Japan.

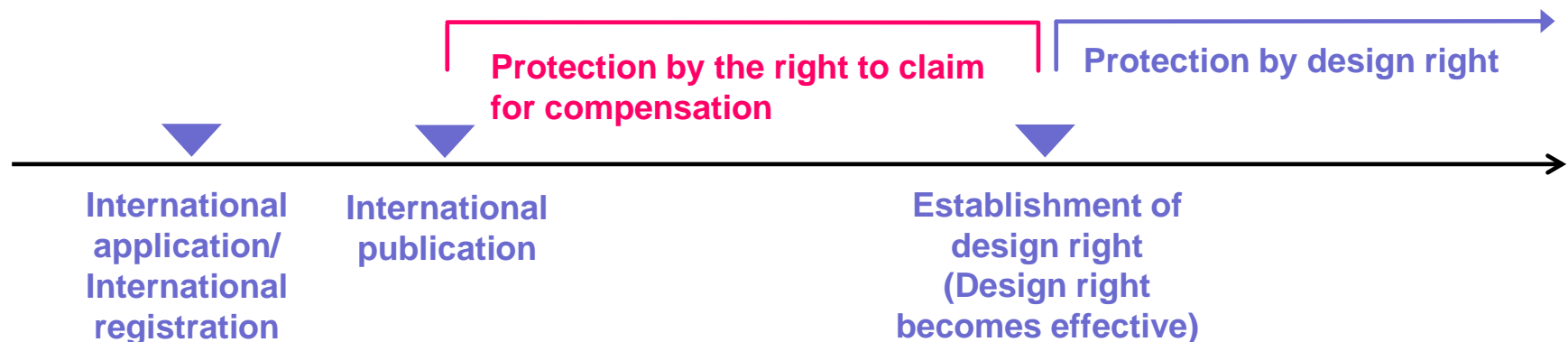

# Individual designation fee

As from  
July 1, 2016

International application	– for each design	582	665
1st renewal	– for each design	659	754
2nd renewal	– for each design	659	754
3rd renewal	– for each design	659	754
4th and subsequent renewals	– for each design	0	0

Amounts (in Swiss francs)

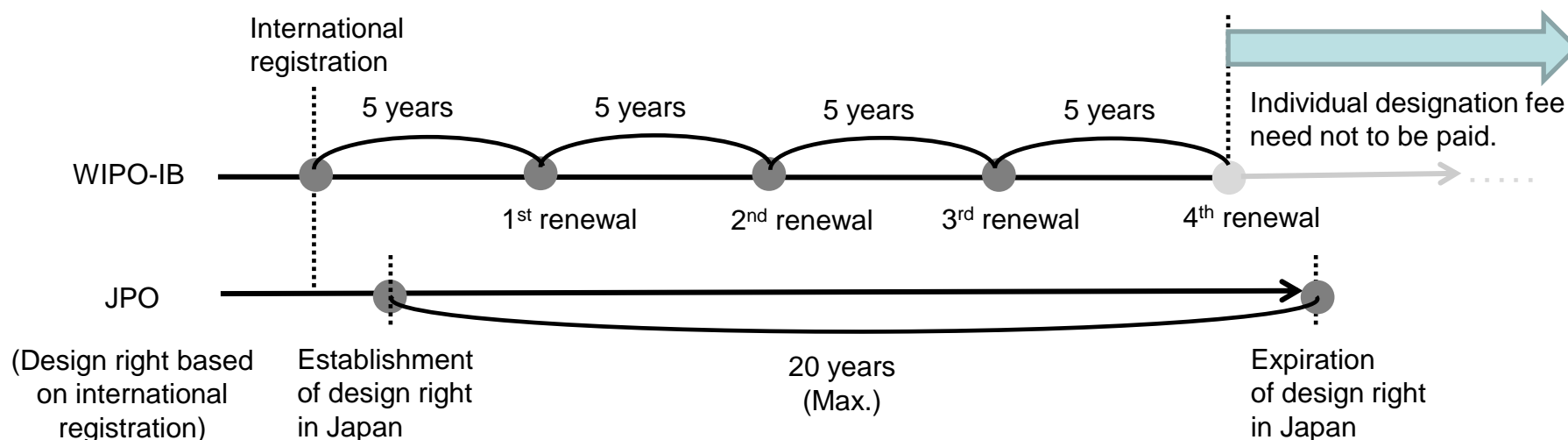



- In the following cases, the individual designation fee which was paid in respect of the designation of Japan may be partially refunded (in Japanese yen) upon request to the JPO within six months;
  - ✓ Where the examiner's decision or trial decision of refusal has become final and binding in Japan, or
  - ✓ Where the application for design registration deriving from an international registration designating Japan has been deemed withdrawn and such an application does not exist any longer (e.g. renunciation and/or limitation of the international registration in respect of Japan, etc.)

Article 7(2)	Individual fee in respect of a designation and a renewal under the 1999 Act
Article 13(1)	Requirement of unity of design
Article 17(3)(c)	Maximum duration of protection under the national law <ul style="list-style-type: none"><li>- 20 years from the date of the registration of the establishment of a design right in Japan.</li></ul>
Rule 9(3)(a)	<u>Certain views of the design required</u> (Mention later) <ul style="list-style-type: none"><li>- where the product which constitutes the industrial design is three-dimensional, a front view, a back view, a top view, a bottom view, a left side view and a right side view, each made in compliance with the method of orthographic projection, are required.</li></ul>
Rule 18(1)(b)	Extension to 12 months of the refusal period
Rule 18(1)(c)(ii)	Date of effect of the international registration <ul style="list-style-type: none"><li>- where a decision regarding the grant of protection was unintentionally not communicated within the period of 12 months from the publication of the international registration, the international registration shall produce the effect referred to in Article 14(2)(a) of the 1999 Act at a time at which protection is granted according to the Design Act of Japan.</li></ul>

More information on the JPO website at:

[http://www.jpo.go.jp/english/applications/hague\\_notes\\_e.htm](http://www.jpo.go.jp/english/applications/hague_notes_e.htm)

- ✓ Notes for the Designation of Japan in an International Design Application under the Geneva Act of the Hague Agreement
- ✓ Design Act (Tentative translation)
- ✓ Design Examination Guidelines
- ✓ Contact

**Thank you very much for your kind attention!**

**Japan Patent Office**

**<http://www.jpo.go.jp/index.htm>**