

ANNEX VIII/ANNEXE VIII

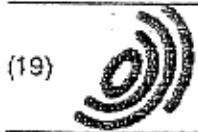

(19)

Europäisches Patentamt
European Patent Office
Office européen des brevets

3

(11)

EP 1 000 000 A1

(12)

EUROPEAN PATENT APPLICATION

(43) Date of publication:
17.05.2000 Bulletin 2000/20

(51) Int. Cl.(1995)
B28B 5/02
B28B 7/00
B28B 1/29 (1996.03)
H05B 3/18 (1997.06)

(21) Application number: 99203729.1

(22) Date of filing: 08.11.1999

(84) Designated Contracting States:
AT BE CH CY DE DK ES FI FR GB GR IE IT LI LU
MC NL PT SE
Designated Extension States:
AL LT LV MK RO SI

(72) Inventor: Kosman, Wilhelmus Jacobus Maria
6562 DA Groesbeek (NL)

(30) Priority: 12.11.1998 NL 1010536

(74) Representative:
Schumann, Bernard Herman Johan et al
Arnold & Siedsma,
Advocaten en Octrooigemachtigden,
Sweelinckplein 1
2517 GK Den Haag (NL)

(71) Applicant: Beheermaatschappij De Boer
Nijmegen B.V.
6541 BS Nijmegen (NL)

(54) Apparatus for manufacturing green bricks for the brick manufacturing industry

(57) The invention relates to an apparatus (1) for manufacturing green bricks from clay for the brick manufacturing industry, comprising a circulating conveyor (3) carrying mould containers combined to mould container parts (4), a reservoir (5) for clay arranged above the mould containers, means for carrying clay out of the reservoir (5) into the mould containers, means (9) for pressing and trimming clay in the mould containers, means (11) for supplying and placing take-off plates for the green bricks (13) and means for discharging green bricks released from the mould containers, characterized in that the apparatus further comprises means (22) for moving the mould container parts (4) filled with green bricks such that a

protruding edge is formed on at least one side of the green bricks.

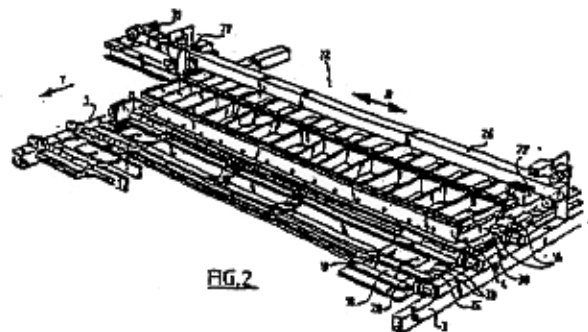

FIG. 2

[Annex IX follows/
L'annexe IX suit]

EP 1 000 000 A1