



Topic 2: **Patent Information**

Lutz Mailänder

Head, International Cooperation on Examination and Training Section

Pretoria
14 March 2016

Overview

- Role of patent information
- Categories of patent information
- Patent publications
- Structured and unstructured data
- INID codes
- Kind codes
- WIPO Standards
- Numbers

Role of patents

- ▶ Two competing interests of two categories of stakeholders:

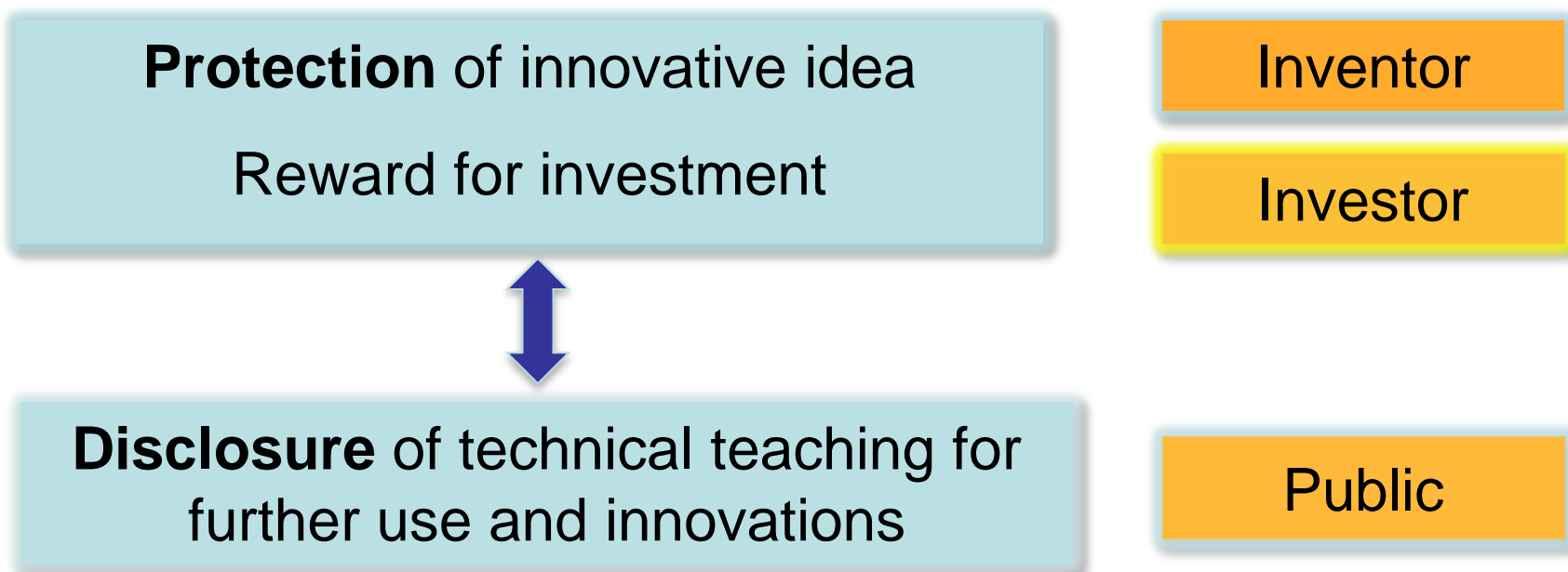

Role of patent information

Patent system: **Protection** <> **Disclosure**

Correspondingly, patent information and its publication serves two purposes:

- ▶ Informing of existing protection rights

What? Where? When?

- ▶ Disclosure and dissemination of technical teaching

How was the problem solved ?

Content of patent **information**

▶ Informing of existing protection rights

What? > see **claims** of granted patent



Where? When? > determine patent family (in Espacenet)
check status in National Patent **Register**

▶ Disclosure and dissemination of technical teaching

How was the problem solved ?

> see **descriptions** and **drawings** of applications or of granted patents

Patent documents/specifications

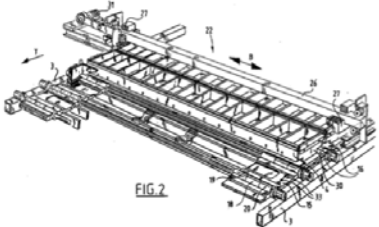
		Europäisches Patentamt European Patent Office Office européen des brevets	
(19)		(11)	EP 1 000 000 A1
(12) EUROPEAN PATENT APPLICATION			
(43) Date of publication: 17.05.2000 Bulletin 2000/20		(51) Int. Cl. ⁷ : B28B 5/02, B28B 7/00, B28B 1/29	
(21) Application number: 99203729.1			
(22) Date of filing: 08.11.1999			
(84) Designated Contracting States: AT BE CH CY DE DK ES FI FR GB GR IE IT LI LU MC NL PT SE Designated Extension States: AL LT LV MK RO SI		(72) Inventor: Kraemer, Wilhelmus Jacobus Maria 6562 DA Groesbeek (NL)	
(30) Priority: 12.11.1998 NL 1010536		(74) Representative: Schumann, Bernard Herman Johan et al Arnold & Siedama, Advocaten en Octrooigemachtigden, Sweelinckplein 1 2517 GK Den Haag (NL)	
(71) Applicant: Beheermaatschappij De Boer Nijmegen B.V. 6541 BS Nijmegen (NL)			
(54) Apparatus for manufacturing green bricks for the brick manufacturing industry			
(57) The invention relates to an apparatus (1) for manufacturing green bricks from clay for the brick manufacturing industry, comprising a circulating conveyor (3) carrying mould containers combined to mould container parts (4), a reservoir (5) for clay arranged above the mould containers, means for carrying clay out of the reservoir (5) into the mould containers, means (9) for pressing and trimming clay in the mould containers,		means (11) for supplying and placing take-off plates for the green bricks (13) and means for discharging green bricks released from the mould containers, characterized in that the apparatus further comprises means (22) for moving the mould container parts (4) filled with green bricks such that a protruding edge is formed on at least one side of the green bricks.	
			
FIG. 2			
<small>Printed by Xerox (UK) Business Services 3 14 7 2400 04</small>			

EP 1 000 000 A1

Components of patent documents

▶ Bibliographic data (front page, meta data)

Sample

- title, applicant(s), inventor(s), filing date, priorities, ..

▶ Description

- problem to be solved, prior art, inventive idea, embodiments

▶ Drawings

▶ **Claims**

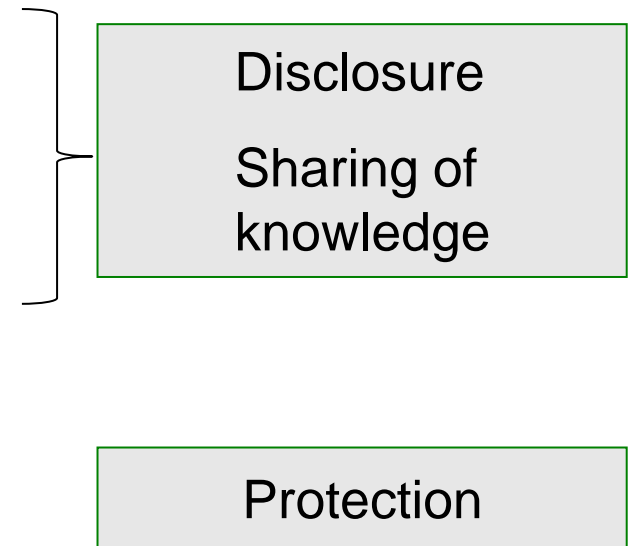

Components of Patent Information

- For each **individual** patent application (publication):
 - bibliographic data (metadata)
 - technical disclosure
 - legal information
 - claims
 - legal status
 - other

Per application: Bibliographic Data

- Traditionally the data on the front page of a patent document
- Now also as data in database (“database front page”)
- Serves to **identify** a patent publication, to **retrieve** it and **relate** it to other "similar" applications
 - same applicant
 - same inventor
 - same patent family
 - same technical field (classification)
- "tagged" with INID codes

Structured/fielded data ("PDF view")

INID codes

NATIONAL APPLICATION PUBLISHED UNDER THE PATENT COOPERATION TREATY (PCT)

(19) World

Classifications



(43) International Publication Date
5 July 2007 (05.07.2007)

PCT

(10) International Publication Number
WO 2007/076115 A2

(11) International Patent Classification:
A01H 5/00 (2006.01) CI2N 15/82 (2006.01)
CI2N 9/10 (2006.01) CI2N 5/04 (2006.01)

5727-107th Street, Edmonton, Alberta, T6G 2E9 (CA).
THEODORIS, George [US/US]
Vallejo, CA 94591 (US).

(21) International Application Number:
PCT/US2006/049241

(74) Agents: AMIL, Lisa, A. et al.; Mc
425 Market Street, San Francisco, CA 94102-2482 (US).

(22) International Filing Date:
21 December 2006 (21.12.2006)

(81) De
kin
AL, AM,
AT,
CH, CN,
CO, CR, CU, CZ, DE, DK, DM, DZ, EC, EE, EG, ES, FI,
GB

(25) Filing Language: English

(26) Publication Language: English

(30) Priority Data:
00753,818 23 December 2005 (23.12.2005) US

JP,
LI,
MZ, NA, NG, NL, NZ, OI, PA, PE, PG, PH, PL, PT, RU, SD,
RU, SC, SD, SE, SG, SK, SI, SM, SV, SY, TI, TM, TN,
TR

(71) Applicant (for all designated States except US): **ARCADIA BIOSCIENCES, INC.** [US/US]; 202 Cousteau Place, Suite 200, Davis, CA 95616 (US).

(84) De
kin
GM, KE, LS, MW, MZ, NA, SD, SI, SZ, TZ, UG, ZM,
ZW), Eurasian (AM, AZ, BY, KG, KZ, MD, RU, TJ, TM),
European (AT, BE, BG, CH, CY, CZ, DE, DK, EE, ES, FI,
FR, GB, GR, HU, IE, IS, IT, LT, LU, LV, MC, NL, PL, PT,
RO, SE, SI, SK, TR), OAPI (BF, BJ, CF, CG, CI, CM, GA,
GN, GQ, GW, ML, MR, NE, SN, TD, TG).

(72) Inventors; and
(75) Inventors/Applicants (for US only): **KRIDL, Jean** [US/US]; 538 Reed Drive, Davis, CA 95616 (US). **DEPAUW, Mary** [CA/CA]; 9508 145th Street, Edmonton, Alberta, T5N 2W7 (CA). **SHRAWAT, Ashok, K.** [IN/CA]; Apt. 2011, 27 Saddleback Road, Edmonton, Alberta, T67 4M4 (CA). **GOOD, Allen, G.** [CA/CA];

Publication number

Filing date

Priority data

Applicant(s)

Title

(54) Title: NITROGEN-EFFICIENT MONOCOT PLANTS

[Continued on next page]

Structured/fielded data ("HTML view")

Mobile | Deutsch | Español | Français | 日本語 | 한국어 | Português | Русский | 中文 |

WIPO  **PATENTSCOPE**

Search International and National Patent Collections

WORLD INTELLECTUAL PROPERTY ORGANIZATION

Search | Browse | Translate | Options | News | Login | Help

Home > IP Services > PATENTSCOPE

↑

1. (WO2007076115) NITROGEN-EFFICIENT MONOCOT PLANTS

PCT Biblio. Data | Description | Claims | National Phase | Notices | Documents

Latest bibliographic data on file with the International Bureau

Pub. No.: WO/2007/076115 **International Application No.:** PCT/US2006/049241
Publication Date: 05.07.2007 **International Filing Date:** 21.12.2006

IPC: *A01H 5/00* (2006.01), *C12N 5/04* (2006.01), *C12N 9/10* (2006.01)

Applicants: ARCADIA BIOSCIENCES, INC. [US/US]; 202 Cousteau Place, Suite 200, Davis, CA 95616 (US) (For All Designated States Except US).
KRIDL, Jean [US/US]; (US) (For US Only).
DEPAUW, Mary [CA/CA]; (CA) (For US Only).
SHRAWAT, Ashok, K. [IN/CA]; (CA) (For US Only).
GOOD, Allen, G. [CA/CA]; (CA) (For US Only).
THEODORIS, George [US/US]; (US) (For US Only)

Inventors: KRIDL, Jean; (US).
DEPAUW, Mary; (CA).
SHRAWAT, Ashok, K.; (CA).
GOOD, Allen, G.; (CA).
THEODORIS, George; (US)

Agent: WARD, Michael, R.; Morrison & Foerster LLP, 425 Market Street, San Francisco, CA 94105-2482 (US)

Priority Data: 60/753,818 23.12.2005 US

Title (EN) NITROGEN-EFFICIENT MONOCOT PLANTS
(FR) PLANTES MONOCOTYLEDONES AYANT UN RENDEMENT EFFICACE EN AZOTE

Abstract: (EN) Methods of increasing nitrogen utilization efficiency in monocot plants through genetic modification to increase the levels of alanine aminotransferase expression and plants

Schematic of Key Steps in Nitrogen Utilization in a Plant Cell

AL PROPERTY IN

No INID codes

Patent information analyses

- Patent information is available as
 - **structured data**: bibliographic information (e.g. INID codes)
 - **unstructured data**: description, claims
- Structured data allow for a focused search
 - Names: applicant, inventor, attorney
 - Dates: priority, application, publication
 - Keywords: title, abstract, description, claim

Fielded search: Multiple fields

■ Example: PATENTSCOPE Field combinations interface

The screenshot displays the 'Structured Search' interface for PATENTSCOPE. It features a 'Fields' section with a list of search fields and logical operators. The fields are: Front Page, WIPO Publication Number, Application Number, Publication Date, Title, Abstract, Applicant Name, International Class, Inventor Name, Office Code, Description, and Claims. Each field is preceded by a dropdown menu set to 'AND'. The fields are separated by equals signs (=) and followed by empty search input boxes. A red box highlights the 'AND' dropdown menus for the first ten fields. At the bottom, there is a section for 'Is Empty' with radio buttons for 'N/A', 'Yes', and 'No'.

Operator	Field	Separator	Input	Help
AND	Front Page	=		?
AND	WIPO Publication Number	=		?
AND	Application Number	=		?
AND	Publication Date	=		?
AND	Title	=		?
AND	Abstract	=		?
AND	Applicant Name	=		?
AND	International Class	=		?
AND	Inventor Name	=		?
AND	Office Code	=		?
AND	Description	=		?
AND	Claims	=		?
AND	Claims			

Is Empty: N/A Yes No

→ Search in multiple fields, combination (AND, OR)



Smart search

Advanced search

Classification search

Quick help

- [How many search terms can I enter per field?](#)
- [How do I enter words from the title or abstract?](#)
- [How do I enter words from the description or claims?](#)
- [Can I use truncation/wildcards?](#)
- [How do I enter publication, application, priority and NPL reference numbers?](#)
- [How do I enter the names of persons and organisations?](#)
- [What is the difference between the IPC and the CPC?](#)
- [What formats can I use for the publication date?](#)
- [How do I enter a date range for a publication date search?](#)
- [Can I save my query?](#)

Related links

Advanced search

Select the collection you want to search in [i](#)

Worldwide - collection of published applications from 90+ countries ▾

Enter your search terms - CTRL-ENTER expands the field you are in

Enter keywords in English

Title: [i](#) plastic and bicycle

Title or abstract: [i](#) hair

Enter numbers with or without country code

Publication number: [i](#) WO2008014520

Application number: [i](#) DE19971031696

Priority number: [i](#) WO1995US15925

Enter one or more dates or date ranges

Publication date: [i](#) yyyyymmdd

Enter name of one or more persons/organisations

Applicant(s): [i](#) Institut Pasteur

Patent information analyses

- Patent information is available as
 - **structured data**: bibliographic data (metadata)
 - **unstructured data**: description, claims, sequence listings
 - **(image data**: drawings, chemical formula)
- **Data mining**: structured data enable an easy
 - statistical analysis
 - network analysis
- **Text mining** of unstructured descriptions/claims/abstracts
 - Determining linguistic (semantic) content/meaning/concepts
 - Similarity between documents

INID codes

- Serve to identify bibliographic data components/fields
- Useful, e.g., for publications in foreign languages, e.g. [CN101612972](#)
- Available on printed and PDF or similar publications
- Not used in databases because they have English language interface
- INID codes are standardized by [WIPO Standard ST.9](#)
 - (11)* Publication number
 - (71)* Applicant name
 - (72) Inventor name
 - (51)* International Patent Classification

[19] 中华人民共和国国家知识产权局



[12] 发明专利申请公布说明书

[21] 申请号 200910151247.2

[51] Int. Cl.

B62K 11/00 (2006.01)

B62J 23/00 (2006.01)

B62J 15/00 (2006.01)

B62J 6/02 (2006.01)

B62J 6/00 (2006.01)

[43] 公开日 2009年12月30日

[11] 公开号 CN 101612972A

[22] 申请日 2009.6.29

[21] 申请号 200910151247.2

[30] 优先权

[32] 2008.6.27 [33] JP [31] 2008-168664

[71] 申请人 雅马哈发动机株式会社

地址 日本静冈县

[72] 发明人 尾形智和 种茂英男

[74] 专利代理机构 北京东方亿思知识产权代理有
限责任公司

代理人 柳春雷 南 霆

权利要求书 2 页 说明书 14 页 附图 17 页

[54] 发明名称

摩托车

[57] 摘要

本发明公开了一种摩托车，其目的是在大车轮
外径的摩托车中减少闪光灯单元的部件数量并充分

WIPO standards for patent information

- WIPO standards provide general **guidance and recommendations** for the presentation, publication and communication of IPR related information
- Not binding
- http://www.wipo.int/standards/en/part_03_standards.html
- E.g.
 - ST.1 Minimum data to identify patent
 - ST.3 Country codes
 - ST.6 Publication numbers
 - ST.9 INID codes
 - ST.16 Publication kind codes

Application numbers

- Each application is numbered serially
- Not each application is published; published application numbers have gaps
- Some countries use application number also as publication number (e.g. DE)
- Other countries use separate numbering of publications (often in serial manner), e.g.

.....

EP100000

EP100001

EP100002

.....

Publication numbers

Samples:

- EP 100000 A1 (format never changed)
- US 100000 A, US 2006/0219052 A1 (format changed once)
- DE 1 A, DE 43012345 A1, DE 10 2006 123456 A1 (several format changes)

EP	100000	A1
Country code	Number	Kind code
ST.3	ST.6	ST.16

Publication numbers

- Numbering
 - May include publication year
 - Sequential without gaps, i.e. ...,111,112,113,114,...
 - Sequential with gaps (usually if same number is used for application number since not all applications are published)
- Presented in different format on PDF publications and in databases
 - Espacenet: US2006219052 (A1)
 - US PDF: US 2006/0219052 (A1)

Stages of patent prosecution

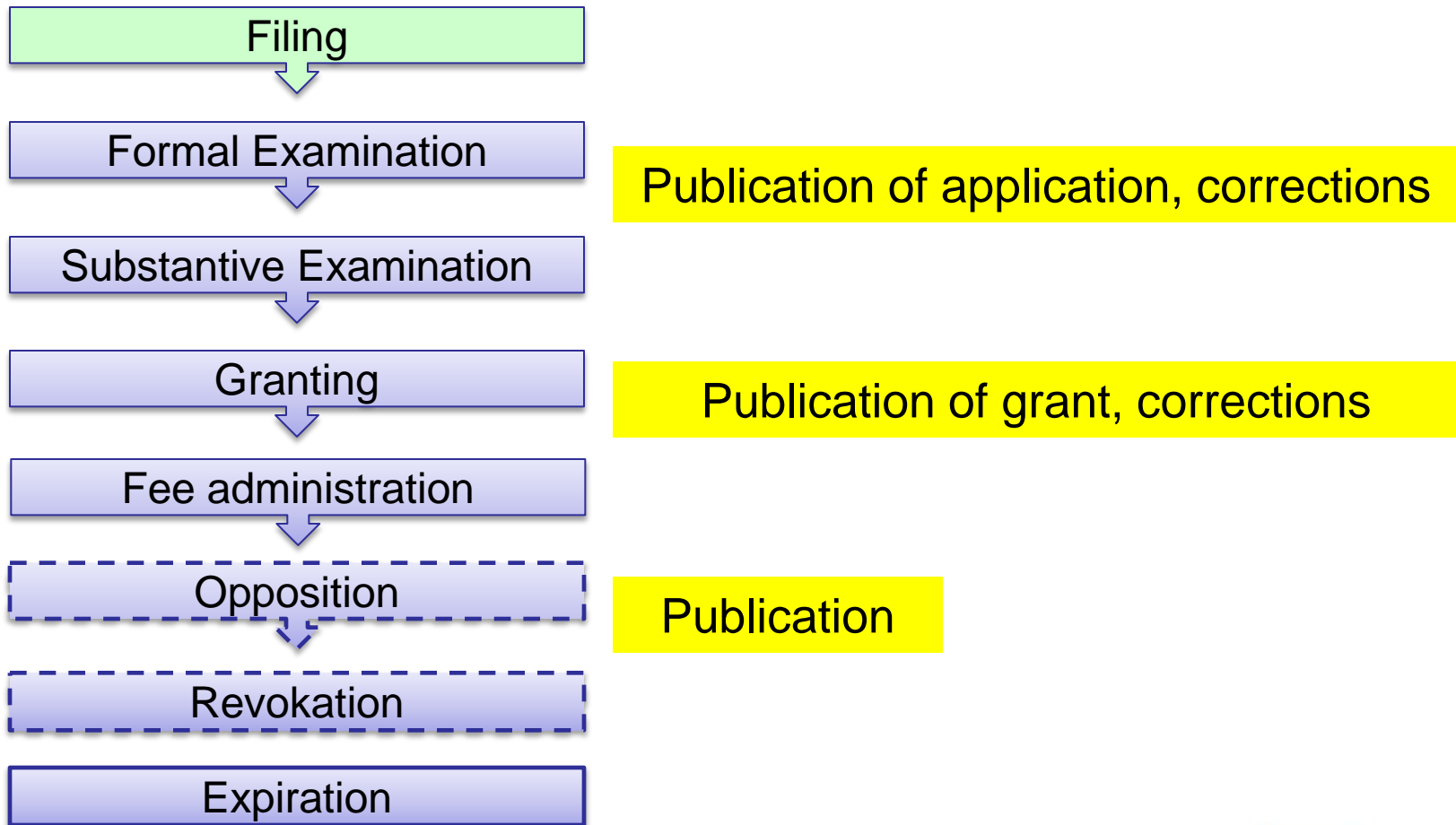

Publication numbers

- Publication at different stages
 - Same number with different kind codes
 - EP1234567A1
 - EP1234567B1
 - Different number with kind codes
 - US 2010/146858 A1
 - US 8,617,271 B2 (purely serial number)

Kind codes 1

- Publication kind codes identify different publication stages of a **single** application, e.g.
 - Initial publication of application
 - Search reports
 - Granted patents
 - Translations
 - Amendments/Corrections
 - They constitute a **domestic family**
- ST.16:
 - A > First level publication of patents
 - B > Second level publication of patents
 - C > Third level publication of patents

Kind codes 2

- National authorities use various kind codes depending on their publication policies
- Overview of national practices:
<http://www.wipo.int/export/sites/www/standards/en/pdf/07-03-02.pdf>
- Overview and samples of front pages:
<http://www.wipo.int/export/sites/www/standards/en/pdf/07-03-03.pdf>
- Example US:
 - up to 10/2000:
 - “A” for publications of granted patents (1st level at that time)
 - no publication of applications
 - since 10/2000:
 - “A1” for publication of applications
 - “B2” for publication of granted patents

International publications

- 18 month after filing/priority date: **WO-A1** or **WO-A2**
- **WO-A1**: international application (IA) + international search report (ISR)
- **WO-A2**: two distinct types of publications
 - International application as filed if no ISR is available yet
 - Optional at later stage: Declaration that no ISR will be established (Article 17(2)(a))
- **WO-A3**: Later publication international search report + front page
- **WO-A4**: Later publication of amended claims and/or statement (Article 19)
- **WO-A8**: Republication front page with corrections
- **WO-A9**: Republication of full application or ISR with corrections, alterations or supplements

Priority numbers

- Priority numbers are usually (reformatted) application numbers of the claimed priority application
- When they are presented on patent documents, they can be differently formatted according to the formatting practice of the publishing authority, ie a priority number published by one office can look different from the corresponding application number published by the priority country office

Bibliographic data over time

- Serve to **identify** a patent publication, to **retrieve** it and **relate** it to other "similar" applications
- Can partially change during and after examination, e.g. assignee/grantee, classification, title,
- No change of application, (publication,) priority numbers, (inventor), dates (except for corrections of errors)
- Changes are usually reflected in databases
- Usually no corrections of issued publications, i.e. front pages of earlier PDF publications do not reflect the changes, e.g. of assignee name

Per application: Legal status data

- All data related to legal **events or actions** as defined by the respective patent law and regulations of a particular **jurisdiction**

events > data change over the lifetime of patents

jurisdiction > different definitions limit comparability

- Essential for determining validity of protection, less essential for examination purposes
- May be relevant for determining examination status at other IPOs
- National **registers** as primary sources
- May change from day to day

Per application: Other Patent Information

- Prior art search reports
- Citation data
- Patent family information, i.e. information on extensions to other OSF
- Examination file (file wrapper; examination reports, search methodologies)
- Value added information (commercial providers)

Enriched prior art search reports



EUROPEAN SEARCH REPORT

Application Number
EP 09 16 8955

Application number

DOCUMENTS CONSIDERED TO BE RELEVANT		
Category	Citation of document with indication, where appropriate, of relevant passages	Relevant to claim
X	EP 0 813 338 A2 (ROCKWELL INTERNATIONAL CORP [US]) 17 December 1997 (1997-12-17) * column 6, line 12 - column 8, line 26 * * column 8, line 52 - column 9, line 4; figure 1 *	1-13
Y	US 6 128 039 A (CHEN DATONG [US] ET AL) 3 October 2000 (2000-10-03) * column 3, line 57 - column 4, line 28; figure 2 *	1,3-7
Y	US 6 163 029 A (YAMADA SHINICHI [JP] ET AL) 19 December 2000 (2000-12-19) * column 15, line 30 - column 16, line 45; figures 2,15,16 *	1,3-7
A	FR 2 864 628 A1 (COMMISSARIAT ENERGIE ATOMIQUE [FR]) 1 July 2005 (2005-07-01) * page 4, line 18 - page 6, line 15; figure 3 *	1-13
A,D	WO 2004/064168 A1 (SCHERRER INST PAUL [CH]; BROENNIMANN CHRISTIAN [CH]; SCHMITT BERND [CH]) 29 July 2004 (2004-07-29) * the whole document *	1-13
E	WO 2009/131151 A1 (HAMAMATSU PHOTONICS KK [JP]; MORI HARUMICHI [JP]; KYUSHIMA RYUJI [JP];) 29 October 2009 (2009-10-29) * figure 12 *	1
The present search report has been drawn up for all claims		
Place of search The Hague		Date of completion of the search 23 March 2010
		Examiner Wulveryck, J
<p>CATEGORY OF CITED DOCUMENTS</p> <p>X : particularly relevant if taken alone Y : particularly relevant if combined with another document of the same category A : technological background O : non-written disclosure P : intermediate document</p> <p>T : theory or principle underlying the invention E : earlier patent document, but published on, or after the filing date D : document cited in the application L : document cited for other reasons & : member of the same patent family, corresponding document</p>		

International Patent Classification

Category X, Y, A, etc.

Relevant to Claim ...

Cited documents

Technical Fields Searched

Searching Authority

Date of Completion of the Search

Examiner

Per application: Other Patent Information

- **Patent family information**, e.g. extensions to other OSF, domestic divisions, continuations:
 - derived from priority claims
 - different family definitions
 - available e.g. via INPADOC database (Espacenet)

Per application: Other Patent Information

- **Examination file** (file wrapper)
 - communication between office and applicant, e.g.
 - search, examination reports
 - amended claims
 - Search methodologies
 - Decisions/rulings
 - Hearing protocols
 - Can be used to check examination status/prospects or prepare opposition
 - parts accessible through file inspection
 - online
 - manual

Beyond a single application: Collective Patent Information

► From collections of patent publications further information can be derived:

- Patterns of patenting activity, e.g. statistical analysis
 - Who is doing what (e.g. top applicants, inventors) ?
 - What is filed where ?
- Patterns of innovation
 - Innovation trends/activities
 - Diversity of technology
 - Innovation tracks
 - Collaborations
- Business information

> Patent Landscape Reports

Aggregations of patent information

Individual application (its bibliographic, technical, legal data, value added data)



Patent family(ies) (domestic, simple, extended; technical)



Patent data collections (e.g. search results)



Collective patent information (Patent landscape reports, FTOs,)

▶ Each subsequent level creates new patent information that is derived by processing the previous aggregation

▶ “Discovering knowledge in patent databases”

ART ?

Citation map
Ritonavir

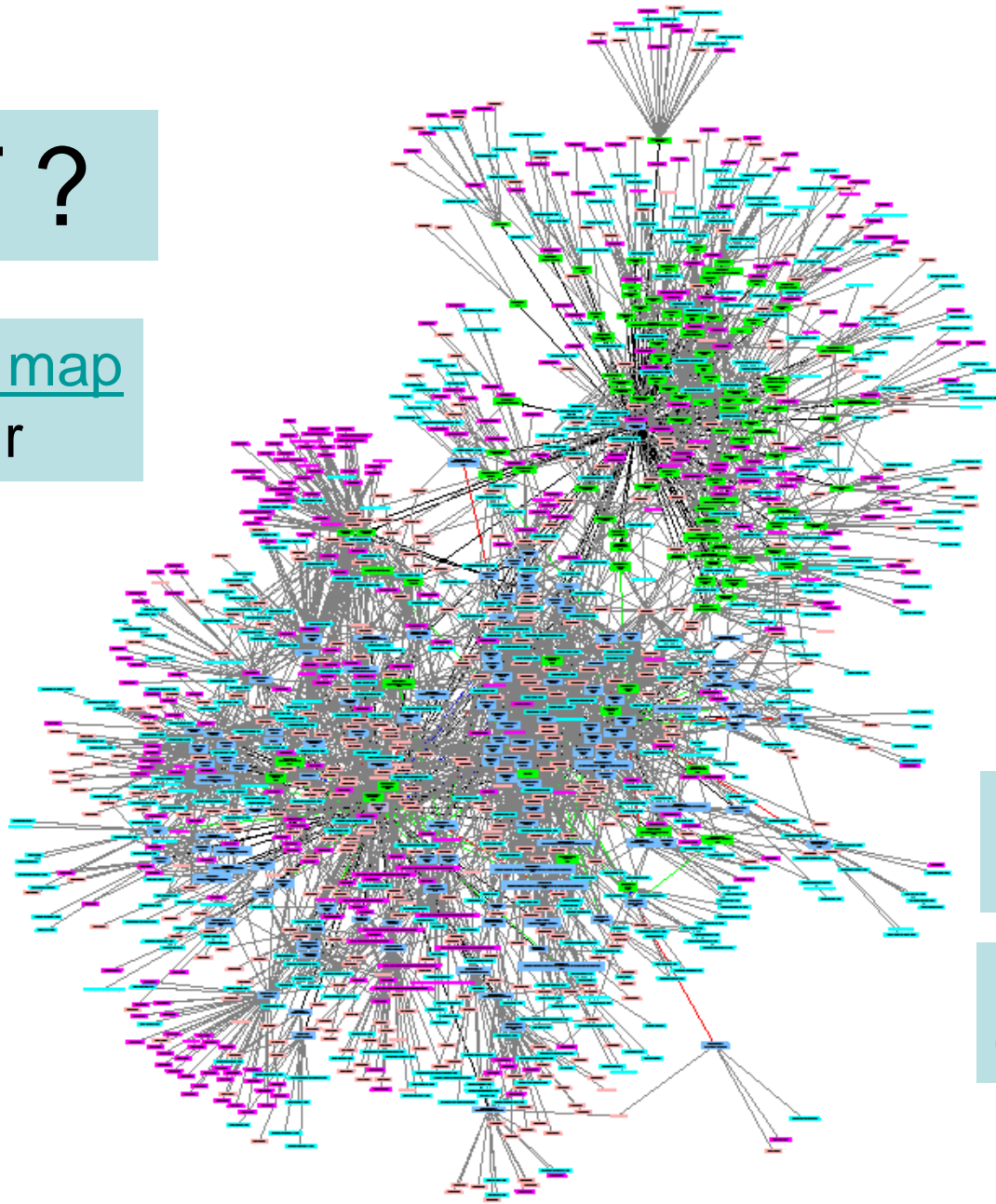

Each box:
Patent publication

Each line:
Citation relation

Thank you

lutz.mailander@wipo.int