

INDUSTRIAL DESIGNS

WHAT IS AN INDUSTRIAL
DESIGN?

HOW IS IT PROTECTED?

“THE FORM OF A PRODUCT”

- What is protected?
 - the aesthetic features of an innovation
- What is not protected?
 - the technical features of an innovation (patents)
 - the distinguishing features of an innovation (trademarks)

SOME DEFINITIONS

- “A pattern for the appearance of an industrial product” (Austria)
- “Any new, original and ornamental design for an article of manufacture” (US)
- “Any composition of lines or colors or any three-dimensional form” (Model Law)

... more definitions

“design means the appearance of the whole or a part of a product resulting from the features of, in particular, the lines, contours, colors, shape, texture and/or materials of the product itself and/or its ornamentation” (EC Directive, October 13, 1998)

Two-Dimensional Designs

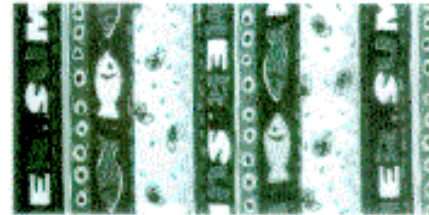

71

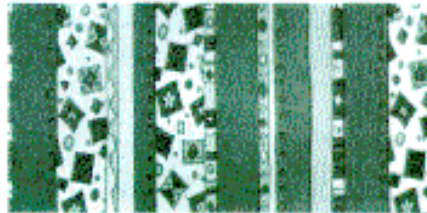

72

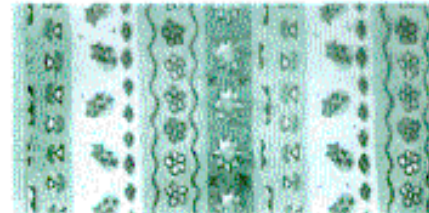

Three-Dimensional Designs

- 3-DIMENSIONAL DESIGNS

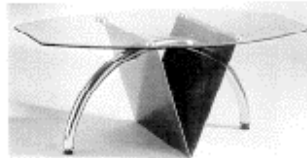
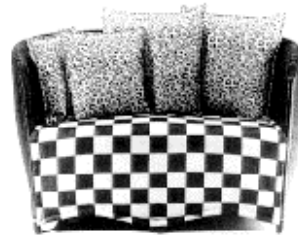
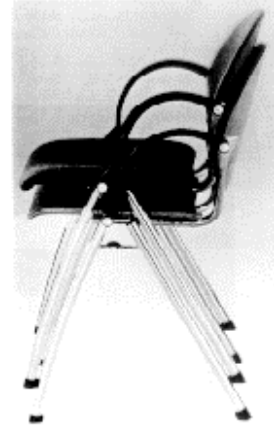

1



2



3



4



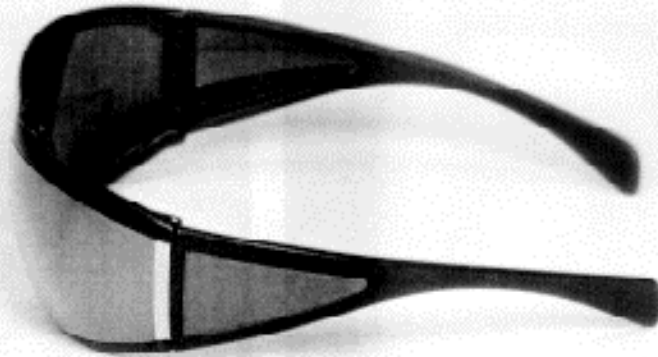

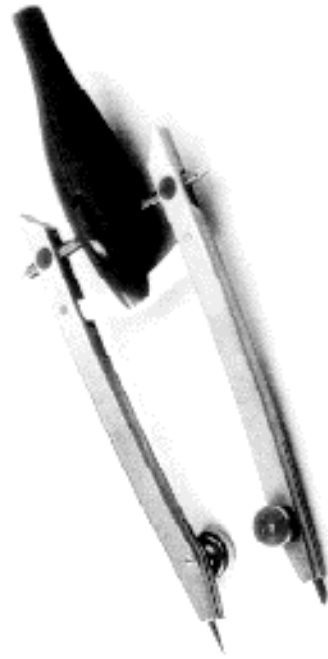
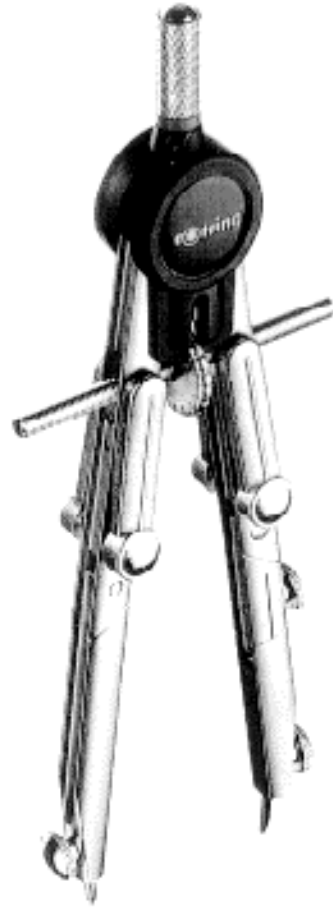

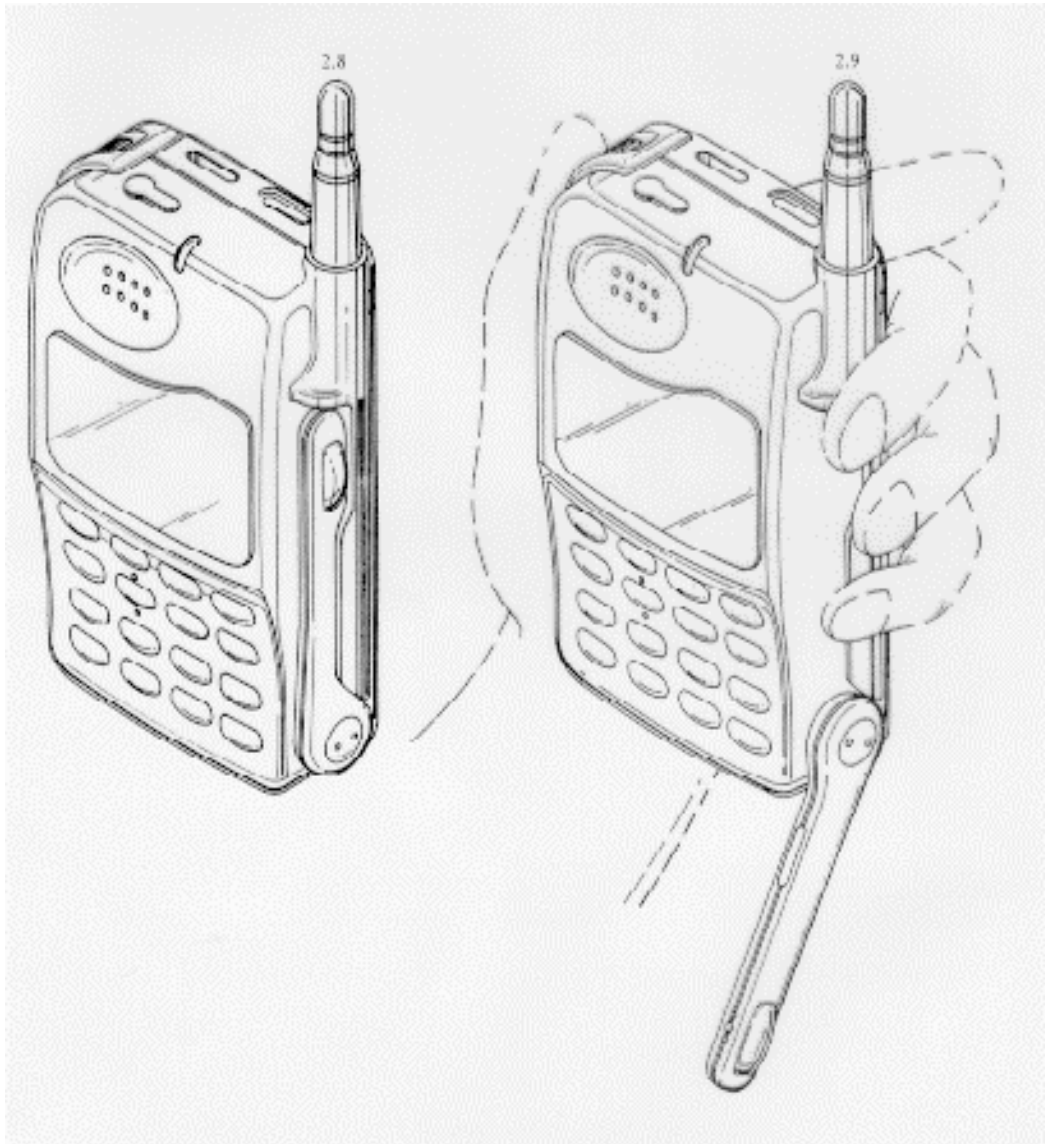

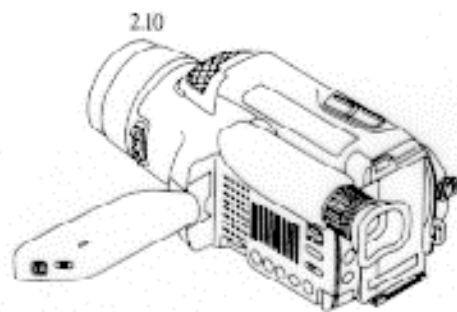
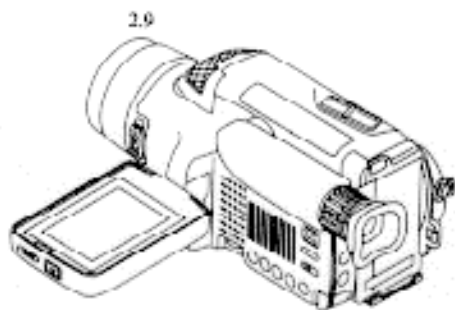
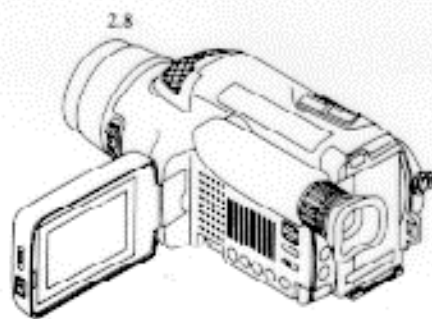
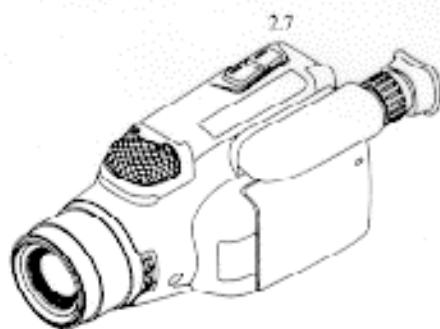

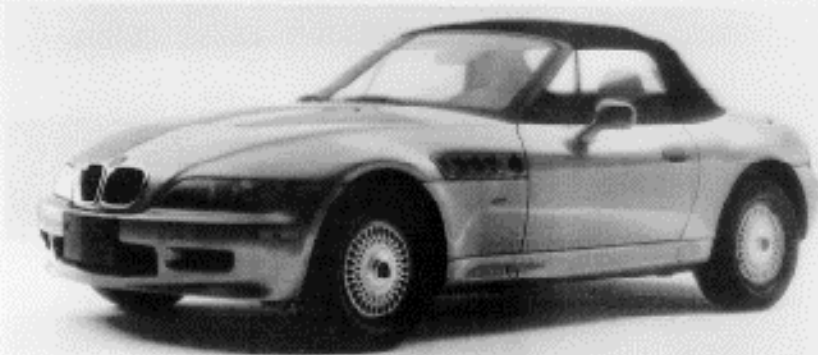

1.2

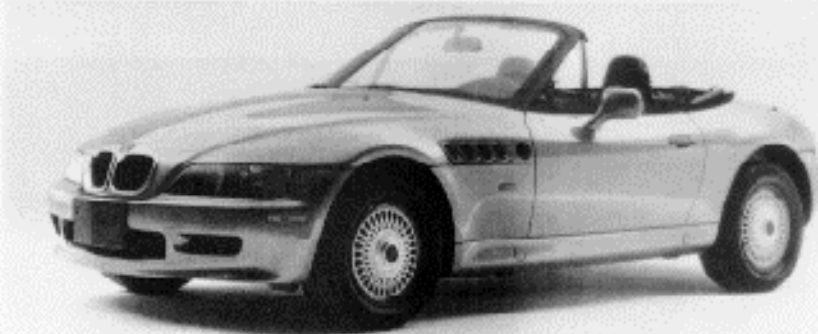

1.3

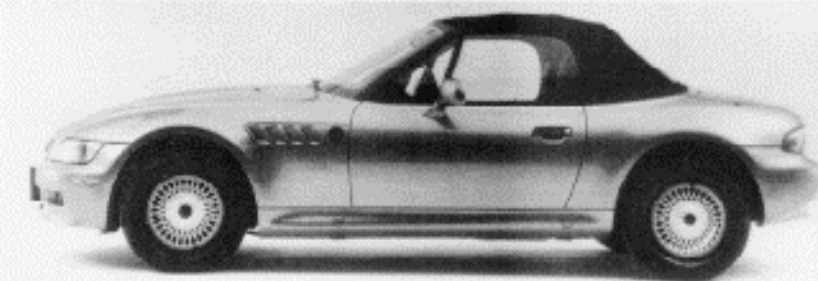

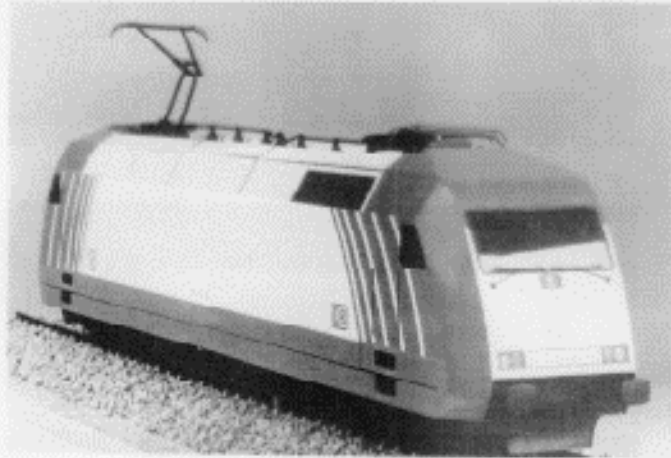

1.2

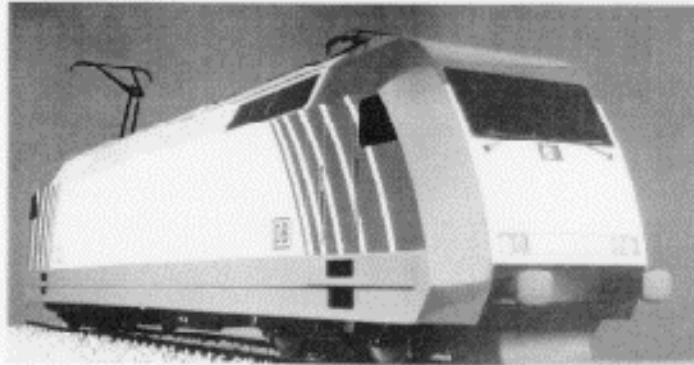

Forms of Protection for Industrial Designs

- Registered Industrial Designs
- Unregistered Industrial Designs
- Copyright
- Three-Dimensional Marks
- Unfair Competition (passing off)
- Cumulative approach
- Mutual exclusion

REGISTERED INDUSTRIAL DESIGNS

- Enforcement upon registration
- Novelty and originality
- Registration procedure

Registration Procedure

- Filing of the application
- Examination
 - absolute grounds for refusal
 - relative grounds for refusal
- Publication
- Renewal
- **Absolute** right

NOVELTY

- No disclosure to the public prior the filing or priority date
- Disclosure
 - publication
 - exhibition
 - use in trade
 - any other disclosure

ORIGINALITY

“Not commonplace in the design field in question at the time of the design’s creation” (UK design right)

Individual Character

“Individual character - if the overall impression the design produces on the informed user differs from the overall impression produced on such a user by any design which has been made available to the public before the filing or priority date” (EC Directive)

22



23



24



25



26



27



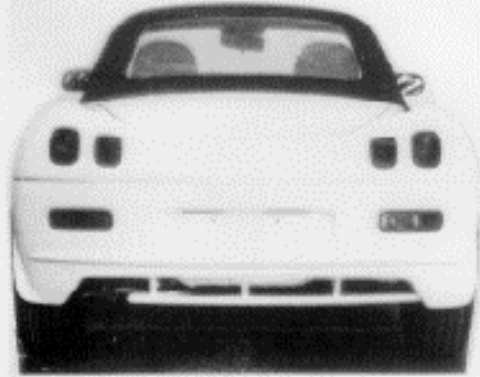

new and/or original?



new and/or original?

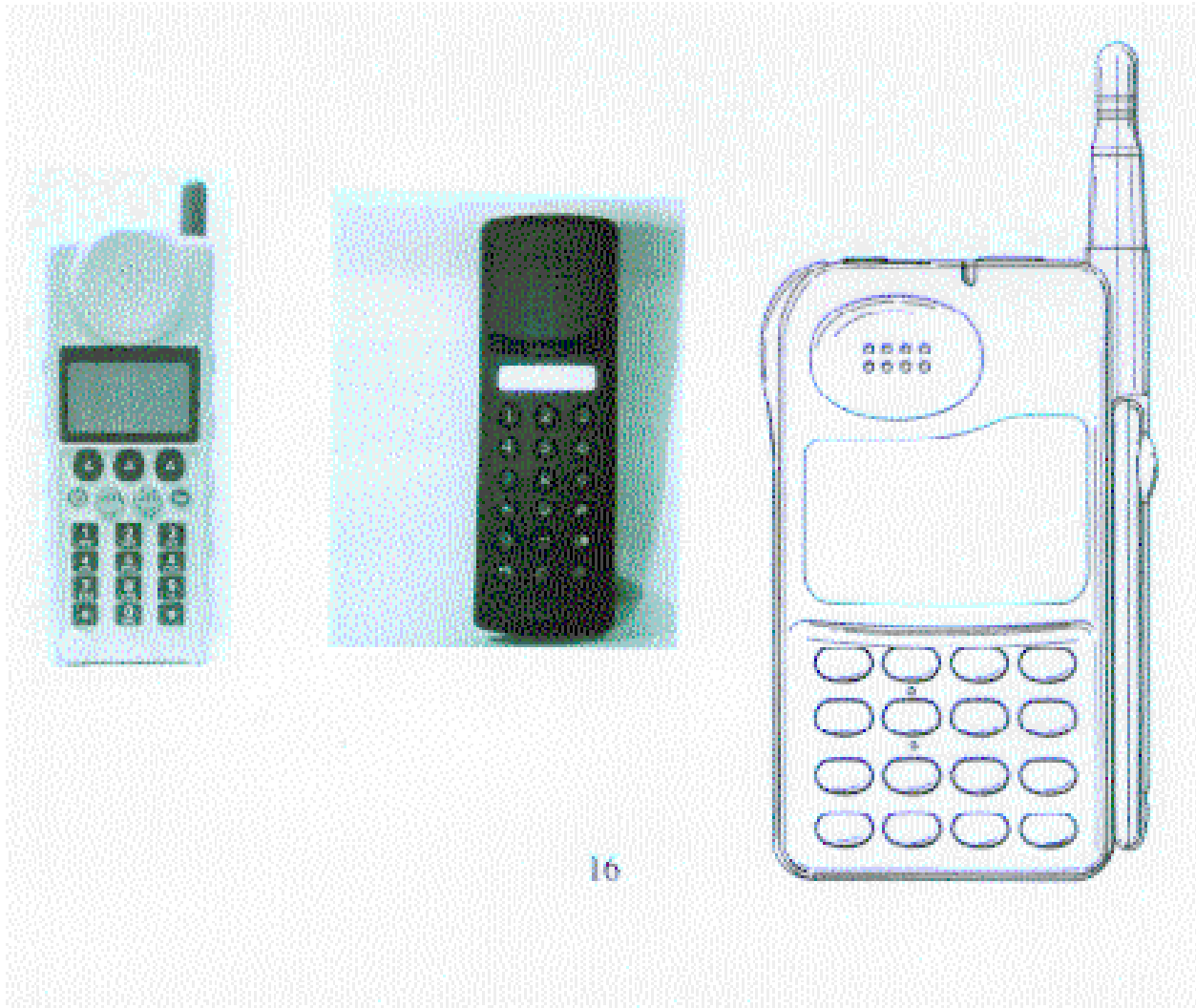

UNREGISTERED INDUSTRIAL DESIGNS

- Enforcement upon publication
- Originality
- No registration procedure is necessary
- Protection against copying only
- Shorter duration of protection

COPYRIGHT

- Enforcement upon creation (fixation)
- Protection for **works of applied art**
- Artistic merit
- No registration procedure
- Protection against copying
- Duration of protection during author's life + 50 (or more) years

Three- Dimensional Marks

- “The shape of goods or their packaging”
- Must be distinctive
- Must not be functional
- Potentially unlimited protection

UNFAIR COMPETITION PASSING OFF

- Right depends on “reputation” or “good will” obtained for the industrial design
- No registration
- Potentially no limitation of the duration of protection



CUMULATIVE APPROACH

Right holder can invoke
cumulatively all existing forms of
protection (ex: France)

EXCLUSIVE APPROACH

The registration of an industrial design excludes other forms of protection, such as, for example, copyright protection



REGISTERED INDUSTRIAL DESIGNS

REGISTRATION PROCEDURE

General Reference to Patent
Application Procedure:

- APPLICATION
- EXAMINATION
- REGISTRATION
- PUBLICATION
- RENEWAL

APPLICATION

- Identity of the Applicant
- Nationality
- Representative
- Representation of the ID(s)
- Specimen (Sample)
- Products (classified)
- Priority Claim
- Fees

Application, continued

- [Request for Deferment of Publication]
- [Description]
- [Claims]
- [Statement of Novelty]

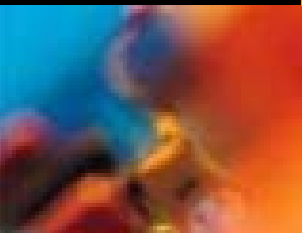

MULTIPLE APPLICATION

Different industrial designs (up to 50, or 100) contained in one application for registration, if they relate to the same class (or sub-class) of goods



10



11

12

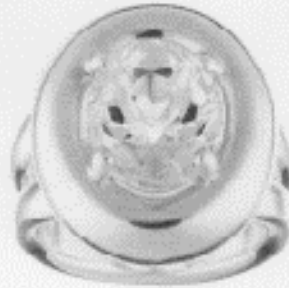

13

14

15



TEXTILE DESIGNS

- Need for protection which is available readily
- Which “in regard to cost, examination or publication does not unreasonably impair the opportunity to seek and obtain it” (TRIPS, Article 25.2)
- Application of copyright protection

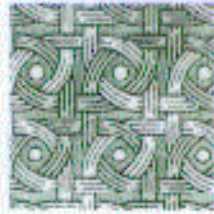

5



6

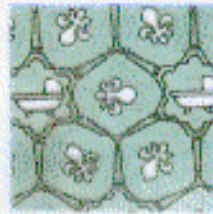

7



8

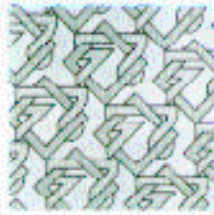

9



10

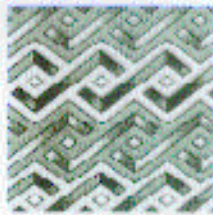

11



12



13

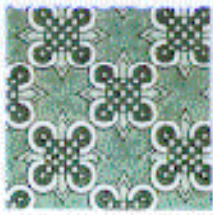

14

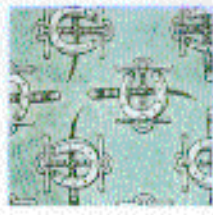

15



16



17



18



19



20



EXAMINATION

- Formal Requirements
 - application is complete and in order
 - fees are paid
- Substantive Requirements
 - novelty
 - absolute
 - relative
 - and/or originality

PUBLICATION

- Upon registration
 - in a Gazette
 - at the public's disposal
- Upon request if publication was deferred (reproduction furnished)
- Deferment of publication
 - registration not enforceable
 - secrecy

RENEWAL

- Limited duration of registration
- Renewal during period which is economically interesting