



# **Shaping Business Strategy Through Competitive Intelligence – Strategic Use of Intellectual Property Information**

**Siyoung Park**  
**Counsellor, Innovation Division, WIPO**  
**[siyoung.park@wipo.int](mailto:siyoung.park@wipo.int)**

# List of Contents



**Patent information General**



**Search Strategy**



**Usage of Patent Information**



**Patent Examination Sample**

**Source: WIPO Guide to Using Patent Information, WIPO  
European Patent Academy, [www.epo.org](http://www.epo.org)**

# Patent Information General

# How does the patent system work?

- **Protection:** A patent allows the patent holder to exclude others from commercially exploiting the invention covered by the patent in a certain country or region and for a specific period of time, generally not exceeding 20 years.
- **Disclosure:** A patent gives the public access to information regarding new technologies in order to stimulate innovation and contribute to economic growth.
- **Since the protection offered by a patent is territorial, covering only the jurisdiction in which the patent has been granted, the information contained in a patent document is global, available as a disclosure to any individual or organization worldwide, thus allowing anyone to learn from and build on this knowledge.**

# Why use patent information ?

- **Patent information is an important resource for researchers and inventors, entrepreneurs and commercial enterprises, and patent professionals.**
- **Patent information can assist users to:**
  - **Avoid duplicating research and development effort**
  - **Determine the patentability of their inventions**
  - **Avoid infringing other inventors' patents**
  - **Estimate the value of their or other inventors' patents**
  - **Exploit technology from patent applications that have never been granted, are not valid, or from patents that are no longer in force**
  - **Gain Intelligence on the innovative activities and future direction of business competitors**
  - **Improve planning for business decisions such as licensing, technology partnerships, and mergers and acquisitions**

# What information does a patent document contain 1

- Patent information comprises all information which either been published in a patent document or can be derived from analyzing patent filing statistics and includes:
- Technology information from the description and drawings of the invention
- Legal information from the patent claims defining the scope of the patent and from its legal status
- Business related information from reference date identifying the inventor, date of filing, country of origin, etc.
- Public policy-related information from an analysis of filing trends to be used by policymakers, e.g., in national industrial policy strategy

# What information does a patent document contain 2

- Patent information comprises all information which either been published in a patent document or can be derived from analyzing patent filing statistics and includes:
- Applicant
- Inventor
- Description
- Claims
- Priority filing, Priority date
- Filing date
- Designated states
- Legal status
- Citations and references
- Bibliographic data

# Where can patent information be found

- Many national and regional patent offices provide free online access to their own patent collections as well as to selected patent documents from other offices. An extensive list of national patent databases can be found at:  
[www.wipo.int/patentscope/dbsearch/national\\_databases.html](http://www.wipo.int/patentscope/dbsearch/national_databases.html)
- WIPO offers free online access to all international patent applications within the framework of the PCT and their related documents and patent collections from National and Regional Offices through its PATENTSCOPE search service:  
<http://patentscope.wipo.int/search>
- A number of commercial and non-profit providers also offer free patent information databases online. Certain commercial providers have established value-added services for access on a fee-paying basis including translations of patent information and additional systematic classification



# How can patent information be used

- **Prior art searches**
- **Gathering business intelligence**
- **Avoiding patent infringement**
- **Patent valuation**
- **Identifying key trend in technology development**

# Search Strategy

# Which strategies can be used to search patent information

- Among the search criteria that can be used to find relevant patents are:
- **Keywords**
- **Patent classification**
- **Dates (e.g., priority date, application date, publication date, grant date)**
- **Patent reference or identification numbers (application number, publication number, patent number)**
- **Names of applicants/assignees or inventors**
- **Most search services permit users to search bibliographic/front page data, that is all data contained in a patent application except the description and claims.**
- **Some search services, including the WIPO PATENTSCOPE search service, allow full-text searches, including the description and claims.**

# Search by Keyword 1

- To target searches effectively, the following tools can be used:
- Word operators: “AND”, “ANDNOT” (“NOT”), “OR”, “XOR”, “NEAR”
  - tennis AND ball : having both the word
  - tennis ANDNOT ball : having the word “tennis” but not “ball”
  - tennis OR ball : having either the word or both
  - tennis XOR ball : having either the word but not both
  - tennis NEAR ball : having both the words within a certain number of words of each other
- Truncation: words can be truncated, i.e., shortened to their primary root or stem, by reducing its length using an operator called a wildcat, usually an asterisk(\*), so as to increase the coverage of the search, for instance: elect\*, all words based on the word stem “elect”, e.g., electricity, electrical, electron

# Search by Keyword 2

- **Nesting:** Nesting refers to the use of parentheses to organize search queries in order to resolve potentially confusing search syntax, for example:
  - **tennis AND ball OR racket** : two potential search outcomes to be resolved (the default order in which different operators are applied in the absence of parentheses may vary between search services)
  - **(tennis AND ball) OR racket** : having either the words “tennis” and “ball” or the word “racket”
  - **tennis AND (ball OR racket)** : having the word “tennis” and either the word “ball” or “racket”
- **Phrases:** If you surround a group of words with quotation mark (“), everything surrounded by those quotation marks will be treated as a single search term. This allows you to search for a multi-word phrase rather than specifying each word as a separate term, for instance: “tennis ball”, having the phrases “tennis ball”

# Search by patent classification 1

- **All patent documents are individually classified using a standardized system identifying the technology group or groups to which the innovation described in the document belong**
- **A widely used system is the International Patent Classification (IPC) System ([www.wipo.int/classifications/ipc](http://www.wipo.int/classifications/ipc))**
- **In its latest edition, it subdivides technology into almost 70,000 fields or groups. Each group describes a specific technology and is identified by a “classification symbol” consisting of a sequence of numbers and letters.**
- **The IPC system is organized according to hierarchical levels. From highest to lowest; these levels are: sections, classes, subclasses, and groups (main groups and subgroups)**

# Search by patent classification 2

■ Each section has a title and specific letter code, as follows:

- **A: Human Necessities**
- **B: Performing Operations; Transporting**
- **C: Chemistry; Metallurgy**
- **D: Textiles; Paper**
- **E: Fixed Constructions**
- **F: Mechanical Engineering; Lighting; Heating; Weapons; Blasting**
- **G: Physics**
- **H: Electricity**

■ From section to subgroup, the code “C21B 7/10” can, for instance, be broken down as follows:

- **Section C: Chemistry; Metallurgy**
- **Class C21: Metallurgy of iron**
- **Subclass C21B: Manufacture of iron or steel**
- **Main group C21B 7/00: Blast furnace**
- **Subgroup C21B 7/10: Cooling; Devices therefor**

# Search in specific data fields 1

- It is often desirable to search for words, numbers, or combinations thereof in a particular data field

The screenshot displays the WIPO Patentscope search interface. The browser address bar shows the URL: <http://patentscope.wipo.int/search/en/structuredSearch.jsf;jsessionid=CA15EE05ED88A8ACC9CEBBCEA432CC5B.wapp2>. The page title is "WIPO - Search International and National Patent Collections".

The main content area is titled "PATENTSCOPE" and "Search International and National Patent Collections". Below this, there is a navigation menu with options: Search, Browse, Translate, Options, News, Login, and Help. The current page is "Field Combination".

The "Field Combination" section contains a table of search fields. Each field is selected with a dropdown menu, and an equals sign (=) is placed between the field name and an empty search input box. The fields are:

Field	Operator	Search Input
Front Page		
AND WIPO Publication Number	AND	
AND Application Number	AND	
AND Publication Date	AND	
AND English Title	AND	
AND English Abstract	AND	
AND Applicant Name	AND	
AND International Class	AND	
AND Inventor Name	AND	
AND Office Code	AND	
AND English Description	AND	
AND English Claims	AND	
AND Licensing availability	AND	<input type="checkbox"/>
AND Inventor Name	AND	Is Empty: <input checked="" type="radio"/> N/A <input type="radio"/> Yes <input type="radio"/> No

At the bottom of the search options, there is a "Language" dropdown set to "English" and a "Stem" checkbox which is checked. Below this is an "Office" dropdown menu.

The Windows taskbar at the bottom shows several open applications: Start, WIPO Applicatio..., Absences Calen..., 받은편지함 | D..., WIPO - Search..., C:\Documents a..., Microsoft Power..., and Inbox - Microsoft... The system clock shows "오후 2:24".



# Search in specific data fields 2

- In the advanced search of the WIPO PATENTSCOPE search service, the filed code “DE” is associated with the “Description” field

The screenshot shows the WIPO PATENTSCOPE search results page. The search criteria are 'DE/semiconductor', 'Office(s):wo', 'Language:EN', and 'Stemming:true'. The results are displayed in a table format, showing the first 10 results of 130,561 total results.

Results 1-10 of 130,561 for Criteria:DE/semiconductor Office(s):wo Language:EN Stemming:true

Refine Search: DE/semiconductor

Analysis

Options: Table (selected), Graph, Options, bar, pie

Countries		Main IPC		Main Applicant		Main Inventor		Pub Date	
Name	No	Name	No	Name	No	Name	No	Date	No
PCT	130561	H01L	26402	KONINKLIJKE PHILIPS ELECTRONICS N.V.	3166	YAMAZAKI, Shunpei	259	2003	6708
		G06F	10347	INTERNATIONAL BUSINESS MACHINES CORPORATION	2662	SILVERBROOK, Kia	124	2004	6869
		G01N	4461	APPLIED MATERIALS, INC.	2403	WALKER, Jay, S.	123	2005	8046
		G02B	3959	INTEL CORPORATION	2137	MIRKIN, Chad, A.	65	2006	9133
		H04L	3350	MICRON TECHNOLOGY, INC.	1225	FORREST, Stephen, R.	53	2007	10413
		H04N	3029	NOKIA CORPORATION	1209	ISHII, Fusao	53	2008	11608
		G11C	2936	ADVANCED MICRO DEVICES, INC.	1209	AISENBREY, Thomas	51	2009	10853
		A61B	2926	HEWLETT-PACKARD	985	BONORA, Anthony, C.	51	2010	10092
		C23C	2539			HABA, Belgacem	51	2011	10944
		G03F	2466			KATHIRGAMANATHAN	51	2012	12149

# Using citations and reference information 1

- Patent applications often contain references to earlier patent documents, particularly in the description section of the application.
- Citations contained in search reports can be a useful way of identifying additional documents related to the technology being investigated or help uncover further search criteria.
  - **Category X:** Document that, taken alone, anticipates the claimed invention, as a result of which the claimed invention cannot be considered novel or cannot be considered to involve an inventive step
  - **Category Y:** Document that, in combination with one or more other such documents, anticipate the claimed invention, insofar as such combination can be considered obvious to a person skilled in the art
  - **Category A:** Document providing technical background information on the claimed invention

# Using citations and reference information 2

id00000019983358[1].pdf - Adobe Reader

File Edit View Window Help

KO Korean Microsoft IME 2003 Han/Eng 漢 Hanja IME Pad

2 / 4 51%

Comment Share

**INTERNATIONAL SEARCH REPORT**

International application No.  
PCT/IB2012/053657

**A. CLASSIFICATION OF SUBJECT MATTER**  
 INV. G08B21/04  
 ADD.

According to International Patent Classification (IPC) or to both national classification and IPC

**B. FIELDS SEARCHED**  
 Minimum documentation searched (classification system followed by classification symbols)  
 G08B

Documentation searched other than minimum documentation to the extent that such documents are included in the fields searched

Electronic data base consulted during the international search (name of data base and, where practicable, search terms used)  
 EPO-Internal

**C. DOCUMENTS CONSIDERED TO BE RELEVANT**

Category*	Citation of document, with indication, where appropriate, of the relevant passages	Relevant to claim No.
X	FR 2 920 575 A1 (OMICRON SOC RESPONSABILITE LIM [FR] OMICRON [FR]) 6 March 2009 (2009-03-06) the whole document	1,2, 4-10, 15-18 3,11-14
Y	US 2010/321184 A1 (DREUILLET PHILIPPE [FR] ET AL) 23 December 2010 (2010-12-23) paragraphs [0001], [0002], [0051] - [0056], [0139] - [0146]; figure 9	3
Y	US 7 916 066 B1 (OSTERHEIL JOSEF [US]) 29 March 2011 (2011-03-29) column 1, lines 50-55 column 5, lines 33-35 column 6, lines 3-23 column 6, line 61 - column 7, line 19 column 17, lines 23-44 column 18, lines 13-42	11-14

-/-

Further documents are listed in the continuation of Box C.  See patent family annex.

\* Special categories of cited documents:

"A" document defining the general state of the art which is not considered to be of particular relevance	"T" later document published after the international filing date or priority date and not in conflict with the application but cited to understand the principle or theory underlying the invention
"E" earlier application or patent published on or after the international filing date	"X" document of particular relevance: the claimed invention cannot be considered novel or obvious in view of the document as a whole
"L" document which may throw doubt on priority, claim(s) or which is cited to establish the publication date of another citation or other special reason (as specified)	"Y" document of particular relevance: the claimed invention cannot be considered to involve an inventive step when the document is combined with one or more other such documents, such combination being obvious to a person skilled in the art
"O" document referring to an oral disclosure, use, exhibition or other means	"S" document member of the same patent family
"P" document published prior to the international filing date but later than the priority date claimed	

Date of the actual completion of the international search	Date of mailing of the international search report
12 December 2012	07/01/2013
Name and mailing address of the ISA/ European Patent Office, P.O. 2010 Patentstr. 2 NL - 2200 HV Rijswijk Tel. (+31-70) 340-2040 Fax (+31-70) 340-9018	Authorized officer: Fagundes-Peters, D

From PCT/ISA/210 (parallel text), (April 2009)

page 1 of 2

1

Start WIPO Applica... Absences Cal... 받은편지함... IB201205365... C:\Document... Microsoft Po... Inbox - Micro... id00000019... << 오후 2:46

# Good practices in searching patent documentation 1

- **The most effective searches exploit all the search options, by using and combining keywords, IPC, and number/date ranges.**
- **Effective searching of patent documentation is a step-by-step process, moving from an initial broad search to increasingly more focused searches.**
- **Ultimately, however, the number of search results must be limited to a reasonable number to allow the individual records to be examined in detail.**

# Good practices in searching patent documentation 2

- **Broad vs. specific search terms: the keywords and IPC used in the first rounds of searching should cover the broad field of technology to which the innovation in question belongs**
  - **searching information on light-emitting diodes**
  - **initially search using keywords: “semiconductor” or IPC such as the subclass: H01L (semiconductor devices)**
  - **rather than the group H01L33/00 (semiconductor devices specially adapted for light emission)**
- **Inclusive/exclusive search operators: certain search operators can be used to broaden your search (inclusive operators), while others serve to narrow your search (exclusive operators)**
  - **Inclusive operators: “OR”**
  - **Exclusive operators: “AND”**

# Usage of Patent Information

# How can patent information be used

- **Prior art searches**
- **Gathering business intelligence**
- **Avoiding patent infringement**
- **Patent valuation**
- **Identifying key trend in technology development**

# Prior art searches

- **Novelty: Is an invention new?**
- **Non-obviousness/Existence of an inventive step: Is the invention sufficiently different from existing technologies?**
- **Searching patent documents is an important step in determining whether an invention is ultimately patentable.**
- **Determine the characteristics of the invention: derive essential words and phrases that will be used in search**
  - **What problem does your invention solve?**
  - **What does your invention do?**
  - **What effect does your invention produce?**
  - **How is your invention construed?**
  - **What materials or methods are used in the construction of your invention?**



# Practical case

- **You have developed a method for printing solar cells onto aluminum foil at low temperatures using a nanoparticle “ink”**
- **Step 1: Identify central concepts related to your innovation**
  - **“solar cell”(product), “aluminum foil”, “nanoparticle ink”(materials used in the production process)**
- **Step 2: Determine keywords for your search**
  - **the next step is to find synonyms and related keywords and phrases for the concepts identified in the first step:**
  - **solar cell: photovoltaic cell (synonym)**
  - **aluminum foil: aluminium foil (alternative spelling),  
metal foil (related term)**
  - **nanoparticle: nanoparticle solution (related term),  
nanoparticle suspension (related term)**

# Practical case

- Step 3: locate the pertinent IPC symbols through IPC publication, search terms (<http://web2.wipo.int/ipcpub>)
- Term “solar cell”, identifies H01L 31/00 as a relevant IPC symbol

The screenshot shows a Microsoft Internet Explorer browser window with the address bar displaying <http://web2.wipo.int/ipcpub/#refresh=page&viewmode=a&notation=scheme&hl=solar%7Ccell&lang=en&version=20130101&>. The page title is "H01L 31/042 - IPC".

The main content area displays search results for the term "solar cell". The results are as follows:

IPC Symbol	Description
<b>H01L 31/00</b>	Semiconductor devices sensitive to infra-red radiation, light, electromagnetic radiation of shorter wavelength, or corpuscular radiation and specially adapted either for the conversion of the energy of such radiation into electrical energy or for the control of electrical energy by such radiation; Processes or apparatus specially adapted for the manufacture or treatment thereof or of parts thereof; Details thereof (H01L 51/42 takes precedence; devices consisting of a plurality of solid state components formed in, or on, a common substrate, other than combinations of radiation-sensitive components with one or more electric light sources, H01L 27/00) [8]
H01L 31/04	... adapted as conversion devices [2]
<b>H01L 31/042</b>	... including a panel or array of photoelectric cells, e.g. solar cells [5]
H01L 31/045	... collapsible or foldable [5]
H01L 31/048	... encapsulated or with housing [5]
H01L 31/05	... characterised by special interconnection means [5]
H01L 31/052	... with cooling, light-reflecting or light-concentrating means [5]
H01L 31/058	... including means to utilise heat energy, e.g. hybrid systems, or a supplementary source of electric energy [5]

The left sidebar contains navigation and search options:

- Language:** English (selected), French, English/French
- View mode:** path (selected), full, hierarchic
- Search:** Terms, Cross-references
- Assistance:** Text categorization (IPCCAT)
- Number of displayed entries:** 500
- Last modified:** 2013.02.08
- Prepared with:** IPCPUBPREP v 2.12

# Practical case

- Step 4: Perform first search (WIPO PATENTSCOPE advance search)
  - Should be relatively broad, using “OR” Boolean operator, using a wildcat operator to include plural forms, and “International Class”
  - “solar cell\*” OR “photovoltaic cell\*” OR IC/ H01L-31\*
  - This search produces over 103,000 results

WIPO PATENTSCOPE  
Search International and National Patent Collections

Home > IP Services > PATENTSCOPE

Results 1-10 of 103,037 for Criteria: "solar cell\*" OR "photovoltaic cell\*" OR IC/H01L-31\* Office(s):all Language:EN Stemming:true

Refine Search "solar cell\*" OR "photovoltaic cell\*" OR IC/H01L-31\* Search RSS Query Tree

Analysis

Options Table Graph Options bar pie

Countries		Main IPC		Main Applicant		Main Inventor		Pub Date	
Name	No	Name	No	Name	No	Name	No	Date	No
PCT	44533	H01L	25704	SHARP CORP	1259	TANIGAWA, HIROYASU	317	2003	3782
European Patent Office	23245	F24J	6854	KYOCERA CORP	788	BEVEC, Dorian	312	2004	4117
Japan	19747	A61K	2481	SANYO ELECTRIC CO LTD	707	YAMAZAKI, Shunpei	115	2005	4665
Republic of Korea	9592	H02J	2269	LG ELECTRONICS INC.	552	ROSEN, Craig, A.	103	2006	5313
Israel	2099	E04D	1856	CANON INC	540	MORI, KEI	65	2007	5979
Russian Federation	1266	H01M	1641	MITSUBISHI ELECTRIC CORP	470	YAMADA YASUSHI	50	2008	7319
South Africa	1113	C03C	1591	MITSUBISHI HEAVY IND LTD	463	FORSELL, Peter	48	2009	9119
Russian Federation (USSR data)	660	C23C	1455	APPLIED MATERIALS, INC.	459	OSHIMA	47	2010	10767
Spain	609	B32B	1415	MATSUSHITA ELECTRIC IND	432			2011	13991
		GR2R	1413					2012	10471

# Practical case

## ■ Step 5: Sharpen search

- the search should be limited using more specific terms and linked using the “AND” Boolean operator
- in order to capture results containing wording such as “nanoparticle solution” as well as “solution containing nanoparticles”, define the distance between 2 words
- (“nanoparticle suspension”~5 OR “nanoparticle solution”~5 OR “nanoparticle ink”~5) AND (IC/“H01L31” OR “solar cell”~5 OR “photovoltaic cell”~5) AND (“aluminum foil” OR “metal foil”)
- This search produces much smaller results
- Among the results are several international applications by Eastman Kodak Company, Hewlett-Packard Development Company L.P.
- “Method of forming a transistor having a dual layer dielectric” etc.

# Gathering business intelligence

- **Knowing which companies or individuals are technology leaders in your area of business**
  - can play important role in planning your commercial and research and development activities
  
- **Patenting activity and patent ownership**
  - can be important in identifying principal innovators in different area of technology

# Practical case

- Your company produces farm equipment and would like to keep track of new developments in plough technology on the international market.
  - Step 1: Determine criteria for your search
    - use IPC symbols to find relevant applications
    - searching the IPC according to “plough”
- (<http://web2.wipo.int/ipcpub>) reveals several technology

The screenshot shows the WIPO IPC Official Publication website. The browser address bar displays the URL: <http://web2.wipo.int/ipcpub/#refresh=page&viewmode=a&notation=scheme&hlf=plough&lang=en&version=20130101&symbol=>. The page title is "WIPO IP SERVICES International Patent Classification (IPC) Official Publication".

The main content area shows a search result for the term "plough". The results are organized into a table with columns for Scheme, RCL, Compilation, Catchwords, and Corrigendum. The search results are as follows:

Scheme	RCL	Compilation	Catchwords	Corrigendum
A			SECTION A — HUMAN NECESSITIES	
			AGRICULTURE	
A01			AGRICULTURE; FORESTRY; ANIMAL HUSBANDRY; HUNTING; TRAPPING; FISHING	
A01B			SOIL WORKING IN AGRICULTURE OR FORESTRY; PARTS, DETAILS, OR ACCESSORIES OF AGRICULTURAL MACHINES OR IMPLEMENTS, IN GENERAL (making or covering furrows or holes for sowing, planting or manuring <a href="#">A01C 5/00</a> ; machines for harvesting root crops <a href="#">A01D</a> ; mowers convertible to soil working <a href="#">apparatus</a> or capable of soil working <a href="#">A01D 42/04</a> ; mowers combined with soil working implements <a href="#">A01D 43/12</a> ; soil working for engineering purposes <a href="#">E01</a> , <a href="#">E02</a> , <a href="#">E21</a> )	
A01B 1/00			Hand tools (edge trimmers for lawns <a href="#">A01G 3/06</a> )	
			<a href="#">Ploughs</a>	
A01B 3/00			<a href="#">Ploughs</a> with fixed <a href="#">plough</a> -shares	
A01B 5/00			<a href="#">Ploughs</a> with rolling non-driven tools, e.g. discs (with rotary driven tools <a href="#">A01B 9/00</a> )	
A01B 7/00			Disc-like soil-working implements usable either as <a href="#">ploughs</a> or as harrows, or the like	
A01B 9/00			<a href="#">Ploughs</a> with rotary driven tools (tilling implements with rotary driven tools <a href="#">A01B 33/00</a> )	
A01B 11/00			<a href="#">Ploughs</a> with oscillating, digging or piercing tools	
A01B 13/00			<a href="#">Ploughs</a> or like machines for special purposes (for drainage <a href="#">E02B 11/02</a> )	
A01B 15/00			Elements, tools, or details of <a href="#">ploughs</a>	

The left sidebar contains navigation options such as "IPC Home Page", "Version" (2013.01), "Current symbol" (A01B), "Language" (English, French, English/French), "View mode" (full, hierarchic), and "Search" (Terms, Cross-references).

# Practical case

- Step 2: Include all relevant groups by using “OR” Boolean operator
- WIPO PATENTSCOPE advance search: “International Class: field code (“IC”)
- IC/ A01B 3 OR IC/ A01B 5 OR IC/ A01B 7 OR IC/ A01B 9 OR IC/ A01B 11 OR IC/ A01B 13 OR IC/ A01B 15 OR IC/ A01B 17
- This search retrieves around 2140 results

WIPO - Search International and National Patent Collections

Home > IP Services > PATENTSCOPE

Results 1-10 of 2,140 for Criteria: IC/ A01B 3 OR IC/ A01B 5 OR IC/ A01B 7 OR IC/ A01B 9 OR IC/ A01B 11 OR IC/ A01B 13 OR IC/ A01B 15 OR IC/ A01B 17 Office(s): all Language: EN Stemming: true

Refine Search: IC/A01B 3 OR IC/A01B 5 OR IC/A01B 7 OR IC/ Search

Analysis

Countries		Main IPC		Main Applicant		Main Inventor		Pub Date	
Name	No	Name	No	Name	No	Name	No	Date	No
European Patent Office	659	A01B	1742	MITSUBISHI AGRICULT MACH CO LTD	110	VAN DER LELY, CORNELIS	39	2003	101
PCT	741	A01C	79	C. VAN DER LELY N.V.	62	VAN DER LELY CORNELIS	30	2004	107
Japan	432	A01D	77	ISEKI & CO LTD	56	BOM CORNELIS	19	2005	112
South Africa	56	E02F	30	KUBOTA CORP	53	JOHANNES GERARDUS	19	2006	104
Israel	23	B62D	26	KUBOTA CORP	53	WAKUTA TAKESHI	19	2007	92
Republic of Korea	15	A01G	20	LELY NV C VAN DER	48	STARIK, Crister	18	2008	97
Russian Federation	6	B60K	15	DEERE & COMPANY	29	VAN DER LELY, ARY	16	2009	88
		B60D	13	KVERNELAND KLEPP AS	26	MINAGAWA ISAO	14	2010	91
		B26G	6	YANMAR AGRICULT EQUIP CO LTD	26	SATOJI HISAYUKI	14	2011	60



# Practical case

- Step 3: Analyze the data
- Navigate to in-depth analysis and visualize the patent activity in tabular or graphical format

The screenshot shows the WIPO PatentSCOPE search results page. The search criteria are: **A01B 3 OR IC: A01B 5 OR IC: A01B 7 OR IC: A01B 9 OR IC: A01B 11 OR IC: A01B 13 OR IC: A01B 15 OR IC: A01B 17 Official Use Language EN Stemming true**. The results are displayed in a table format, and the analysis section shows a bar chart and a table of main applicants.

**Table 1: Search Results**

Countries	Main IPC	Main Applicant	Main Inventor	Pub Date
European Patent Office	A01B 1742	MITSUBISHI AGRICULT MACH CO LTD	VAN DER LELY, CORNELIS	2003 101
PCT	A01C 78	C. VAN DER LELY N.V.	VAN DER LELY CORNELIS	2004 107
Japan	A01D 77	ISEKI & CO LTD	BOM CORNELIS	2005 112
South Africa	E02F 30	IBOTA CORP	JOHANNES GERARDUS	2006 104
Israel	B62D 28	LELY NV C VAN DER	YAMKITA TAKESHI	2007 92
Republic of Korea	A01D 20	DEERE & COMPANY	STARIC, Chester	2008 87
Russian Federation	B60K 15	KVERNELAND KLEPP AS	VAN DER LELY, ARY	2009 88
Spain	B60D 13	YANMAR AGRICULT EQUIP CO LTD	MINGAMMA SAD	2010 91
Mexico	B25D 8	MASLAND NV	SATOJI HISAYUKI	2011 80
	F18D 6	HONDA MOTOR CO LTD	CORNA ENRICO MARIA	2012 51
			BIGREVELAND, Magne	2011 12

**Table 2: Main Applicant Analysis**

Main Applicant	Name	No #
MITSUBISHI AGRICULT MA		110
C. VAN DER LELY N.V.		62
ISEKI & CO LTD		56
IBOTA CORP		53
LELY NV C VAN DER		48
DEERE & COMPANY		28
KVERNELAND KLEPP AS		26
YANMAR AGRICULT EQUIP CO LTD		26
MASLAND NV		25
HONDA MOTOR CO LTD		25



# Practical case

- Step 4: Keep track of current information
- By subscribing to the RSS feed, you can remain up-to-date on the latest international applications relevant to your business

The screenshot shows a web browser window displaying a patent search results page. The address bar shows the URL: <http://patentscope.wipo.int/search/rss.jsf?query=IC%2F+A01B+3+OR+IC%2F+A01B+5+OR+IC%2F+A01B+7+OR+IC%2F+A01B+9+OR+IC%2F+A01B+11+OR+IC%2F+A01B+13+OR+IC%2F+A01B+15+OR+IC%2F+A01B+17>. The page content includes a yellow box with the following text:

**PATENTSCOPE: IC/ A01B 3 OR IC/ A01B 5 OR IC/ A01B 7 OR IC/ A01B 9 OR IC/ A01B 11 OR IC/ A01B 13 OR IC/ A01B 15 OR IC/ A01B 17**  
 You are viewing a feed that contains frequently updated content. When you subscribe to a feed, it is added to the Common Feed List. Updated information from the feed is automatically downloaded to your computer and can be viewed in Internet Explorer and other programs. [Learn more about feeds.](#)  
[Subscribe to this feed](#)

On the right side, there is a sidebar with the following information:

Displaying 300 / 300  
  
 ● All 300  
 -----  
 Sort by:  
 ▾ Date  
 Title

The main content area shows the following patent abstracts:

**TILLER HOUSING**  
 2013년 3월 1일 금요일, 오전 1:00:00 →  
 A tiller (10) includes a tiller frame (12) and an upright assembly (24) extending from the frame. The frame is supported by at least one wheel (14) and defines a cavity (26). A transmission assembly (390) is supported by the frame and has an output member that is configured to be drivingly coupled to a first power source in a first battery-powered configuration and to a second power source in a second electric-powered configuration. A tilling implement (22) includes a drive shaft (48) that is driven by the output member. The tilling implement comprises at least one tine plate (50). The cavity (26) is configured to removably receive a battery (30) in the first battery-powered configuration and removably receive a ballast (356) in the second electric-powered configuration.

**TURF TREATMENT**  
 2013년 3월 1일 금요일, 오전 1:00:00 →  
 A method for the treatment of turf (11) comprising grass (12) growing in a matrix (15, 16) comprising removing matrix (15, 16) including any thatch and other infestation by blading (18) moving through the matrix (15, 16) to a predetermined depth (d). The method may be used to treat turf (11) reinforced with artificial grass (13). Equipment for carrying out the treatment comprises a bladed rotor (17) rotating about a horizontal axis.

**AGRICULTURAL TRACTOR LINKAGE CONTROL SYSTEM**  
 2013년 3월 1일 금요일, 오전 1:00:00 →

The browser's taskbar at the bottom shows several open applications: Start, WIPO Applications f..., 5 Internet Explo..., Inbox - Microsoft Ou..., N:\Orgsme\SHARED\..., C:\Documents and S..., Microsoft PowerPoin..., and a system tray showing the time as 오후 3:47.

# Avoiding patent infringement

- **Having identified relevant patent documents, the first step is to examine the legal status of the patent application:**
  - **Has the patent been granted, rejected, withdrawn, or is it still pending?**
  - **In which countries?**
  - **Is the patent still valid, or has it expired?**
  
- **If a patent is in force in a particular jurisdiction in which you wish to market your product, the second step is to appraise the claims made under this patent**
  
- **Potential infringements can be avoided by modifying your product to take into account these claims**

# Patent valuation

- **Patent documentation can provide an indication as to the value of patents that you or your competitors have been granted.**
- **The citation information contained in patent documents subsequent to a particular patent can be useful for estimating the value of the patent in question.**
- **The number of times a patent is cited in later patent documents is indicative of its technical relevance and thus of its value.**

# Identify key trends in technology development

- **Statistical data obtained from patent documents can be used to map key trends across different fields of technology and different countries**
- **Depending on the criteria according to which patent data can be broken down**
  - **it can be used to track the growth and changes in patent activity over time**
  - **examine the distribution of patent application in a country by residents compared to non-residents**
  - **identify the technology areas in which a country is predominantly active in terms of patenting activity**

# Practical case

- Your government has identified the absence of adequate food preservation technology as a key obstacle to further development of agricultural export sector and is considering negotiating technology transfer agreement with other countries
- Step 1: Determine Criteria for your search
  - Field of technology: A23L 3/00 (“food preservation”)

The screenshot shows the WIPO IP SERVICES website for the International Patent Classification (IPC) Official Publication. The browser address bar shows the URL: <http://web2.wipo.int/ipcpub/#refresh=page&viewmode=a&notation=scheme&hlf=Food%7Cpreservation&lang=en&version=2013.01>. The page displays the IPC Home Page with various navigation options and a search bar.

The main content area shows the IPC Scheme for A23L 3/00. The left sidebar contains navigation options such as Language (English, French, English/French), View mode (path, full, hierarchic), and Search (Terms, Cross-references). The main table lists the classification scheme and its corresponding description:

Scheme	RCL	Compilation	Catchwords	Corrigendum
		Note(s)		
		Attention is drawn to the following places:		
		<b>C08B</b>	Polysaccharides, derivatives thereof	
		<b>C11</b>	Animal or vegetable oils, fats, fatty substances or waxes	
		<b>C12</b>	Biochemistry, beer, spirits, wine, vinegar	
		<b>C13</b>	Sugar industry.	
			<b>FOODS, FOODSTUFFS, OR NON-ALCOHOLIC BEVERAGES, NOT COVERED BY SUBCLASSES A21D OR A23B-A23J; THEIR PREPARATION OR TREATMENT, e.g. COOKING, MODIFICATION OF NUTRITIVE QUALITIES, PHYSICAL TREATMENT (preservation of flour or dough for baking A21D) [8]</b>	
			<b>Preservation of foods or foodstuffs, in general, e.g. pasteurising, sterilising, specially adapted for foods or foodstuffs (preserving foods or foodstuffs in association with packaging B65B 55/00)</b>	
			• by heating using irradiation or electric treatment (drying or kilning A23L 3/40) [5]	
			• by treatment with pressure variation, shock, acceleration or shear stress [5]	
			• by heating materials in packages which are progressively transported, continuously or stepwise, through the apparatus (A23L 3/005 takes precedence) [5]	
			• by heating materials in packages which are not progressively transported through the apparatus (A23L 3/005 takes precedence) [5]	
			• by heating loose unpacked materials (A23L 3/005 takes precedence) [5]	
			• by irradiation without heating	
			• by treatment with electric currents without heating effect	
			• by treatment with chemicals	
			• Freezing; Subsequent thawing; Cooling [5]	
			• by drying or kilning; Subsequent reconstitution [5]	

# Practical case

- Step 2: perform search and Step 3: Analyze the data
- WIPO PATENTSCOPE advanced search (IC/ A23L 3)

WORLD INTELLECTUAL PROPERTY ORGANIZATION

Search Browse Translate Options News Login Help

Home > IP Services > PATENTSCOPE

Results 1-10 of 36,545 for Criteria IC: A23L 3 Office(s) all Language EN Stemming true

prev 1 2 3 4 5 6 7 8 9 10 next Page 1 / 3651 Go

Refine Search IC: A23L 3 Search RSS Query Tree

Analysis

Options Table Graph Options bar pie

Countries		Main IPC		Main Applicant		Main Inventor		Pub Date	
Name #	No #	Name #	No #	Name #	No #	Name	No #	Date #	No #
PCT	14916	A23L	20217	NESTEC S.A.	464	Кедренко Олег Иванович (RU)	978	2003	1963
European Patent Office	10949	A61K	2343	UNILEVER N.V.	404	SUZUKI KISAKU	75	2004	2335
Japan	4406	A23B	1387	UNILEVER NV	382	SUZUKI MAKOTO	58	2005	2289
Republic of Korea	3316	A23C	1352	THE PROCTER & GAMBLE COMPANY	380	PRAKASH, Indra	47	2006	2295
Russian Federation	1342	A23G	1119	SOCIETE DES PRODUITS NESTLE S.A.	359	BON, YOUNG SUK	43	2007	2116
South Africa	986	A21D	1082	NESTLE SA	350	WAKASA AKIRA	37	2008	2278
Israel	266	A23F	862	NESTLE SA	327	AOKI MINORU	35	2009	2430
Mexico	153	A23D	822	UNILEVER PLC	327	Мартович Валерий Иванович (RU)	31	2010	2708
Spain	40	A23K	808	NESTEC SA	237	Корнева Елена Павловна (RU)	29	2011	1800
ARIPO	16	A23J	762	AJINOMOTO KK	235	YAMAZAKI AKIRA	25	2012	1264
				DSM IP ASSETS B.V.	206			2013	188

Options Table Graph Options bar pie

Countries Main IPC Main Applicant Main Inventor Pub Date

0 50 100 150 200 250 300 350 400 450

Main Applicant	Name	No #
NESTEC SA	NESTEC SA	464
UNILEVER N.V.	UNILEVER N.V.	404
UNILEVER NV	UNILEVER NV	382
THE PROCTER & GAMBLE	THE PROCTER & GAMBLE	380
SOCIETE DES PRODUITS NESTLE SA	SOCIETE DES PRODUITS NESTLE SA	359
NESTLE SA	NESTLE SA	350
UNILEVER PLC	UNILEVER PLC	327
NESTEC SA	NESTEC SA	237
AJINOMOTO KK	AJINOMOTO KK	235
DSM IP ASSETS B.V.	DSM IP ASSETS B.V.	206



# Practical case

## Step 3: Analyze the data

### - Visualization of search results by countries, by publication date

The screenshot displays the WIPO PATENTSCOPE search results page for the criteria (C)A23L 3. The page is divided into two main sections: a search results overview and an analysis section.

**Search Results Overview:**

- Home > IP Services > PATENTSCOPE
- Results 1-10 of 36,505 for Criteria (C)A23L 3 Office(s) all Language EN Stemming true
- Page 1 of 3651
- Refine Search: (C)A23L 3

**Analysis Section:**

The analysis section provides a visual breakdown of the search results by country and by publication date.

**Countries Analysis:**

A pie chart shows the distribution of patents by country. The largest share is from the European Patent Office, followed by PCT, Japan, and the Republic of Korea. Other countries include Russian Federation, South Africa, Israel, Mexico, Spain, ARIPO, and Singapore.

Country	No #
PCT	14918
European Patent Office	10949
Japan	4486
Republic of Korea	3316
Russian Federation	1342
South Africa	966
Israel	266
Mexico	153
Spain	40
ARIPO	16
Singapore	3

**Pub Date Analysis:**

A bar chart shows the number of patents published each year from 2003 to 2013. The number of patents generally increases over the period, peaking in 2009.

Pub Date	No #
2003	1963
2004	2335
2005	2289
2006	2295
2007	2116
2008	2278
2009	2430
2010	2708
2011	1680
2012	1264
2013	188

The analysis section also includes a table with columns for Countries, Main IPC, Main Applicant, Main Inventor, and Pub Date. The table is currently sorted by Pub Date Desc.

# Patent Examination Sample



# The invention

A **heating element** for a washing machine which is cheap and compact and helps to reduce water consumption.

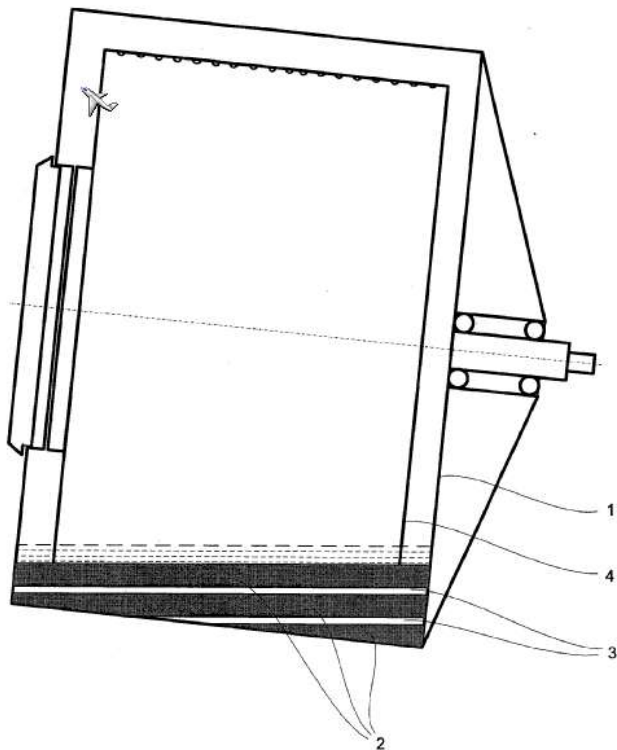

The heating element is a foil heating element at the bottom of the tub of a washing machine.

# The invention

A **heating element** for a washing machine which is cheap and compact and helps to reduce water consumption.

How can you protect it from imitation?

- "cheap", "helps to reduce ..."  
→ too vague and subjective
- "compact"  
= technical function → patent

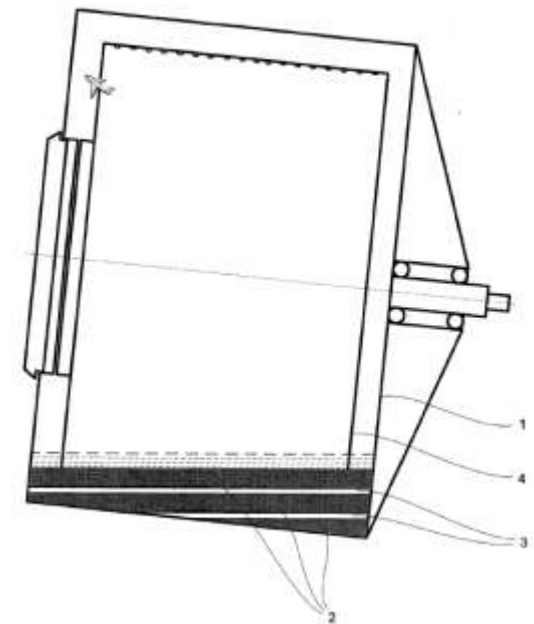

# How to patent this invention: claim it!

Patent Claim:

"A heating element for a washing machine which is compact ..."

No, this is stating the technical problem. Problems cannot be patented – only specific solutions.

What are the **technical features** that solve the problem and make the heating element compact?

Patent Claim: "A washing machine with a heating element for heating **water** inside the tub of the washing machine wherein the heating element is arranged in and adapted in its shape to **the bottom of the tub.**"

You don't want anyone circumventing the patent by heating something other than water or by arranging the heating element at a different point not exactly at the bottom of the tub.

# How to patent this invention: claim it!

Patent claim: "A washing machine with a heating element for heating **a medium** inside the tub of the washing machine, wherein the heating element is arranged in and adapted in its shape to **the tub**."

A prior art search will show whether the invention  
– **as claimed** – is actually **new**.

# Result of the prior art search

The prior art search found a document that shows a similar heating element for a washing machine.

 European Patent Office  
 European Patent Office  
 Office européen des brevets

Publication number: **0 352 499 A2**

**EUROPEAN PATENT APPLICATION**

Application number: 82118864      Int. Cl.: D06F 39/04, D06F 58/25

Date of filing: 05.06.82

Priority: 28.07.81 IT 457588

Date of publication of application: 21.07.82 Bulletin 16/82

Designated Contracting States: DE FR GB IT NL SE

Applicant: **INDUSTRIE ZARROSS s.p.a.**  
 via Saverio Cottone 8  
 I-35119 Pordenone(IT)

Inventor: **Sestini, Piero**  
 via Lario 7  
 I-32045 Povegliano (Pordenone)(IT)

Representative: **Gross, Wolfgang et al**  
 Patentanwälte Hammer-Tranckl  
 Straubinger Strasse, Buchhorn & Partner  
 Postfachnummer A-1010  
 D-8056 München 71 (DE)

**A heating device for washing and/or drying machines for laundry.**

A heating device for washing and/or drying machines for laundry, comprising a parallelepiped plate (1) made of electrically insulating material having applied to one surface thereof, by the ink screen process or similar procedure, at least one electrical resistor (2) based on electrically conductive material powder's mixed with glass (3), the resistor having a wavy or other pattern.

The plate (1) is placed inside the vessel of the washing or drying machine for laundry and the corresponding terminals (4, 7) of the resistor (2) are then connected with the power supply network of the machine.

One thin vitreous or vitreous heat-retaining capacity of the plate (1) is selected to effect rapid heating of the laundry in the machine or the like at all of the machine's operation.

**FIG. 1**

**EP 0 352 499 A2**

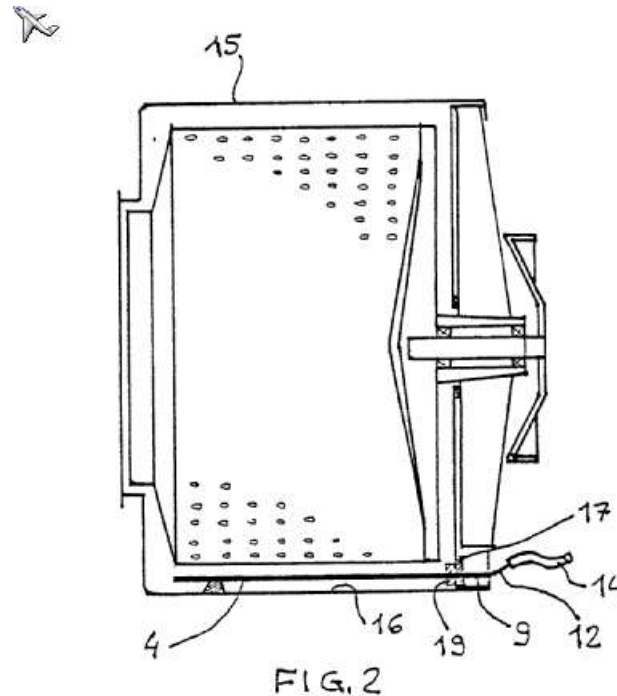

"... curved plate of electrically insulating material with electrically conductive material applied to at least one surface thereof ..."

# Comparison of the two inventions

The invention  
as claimed

"A washing machine with a **heating element** for heating a medium inside the tub of the washing machine wherein the heating element **is arranged in** and adapted in its shape to the tub."

"... a foil heating element ... which is fitted to and adapted in its shape to the tub ..."

EP 0 352 499 A2

"The heating device ... is mounted in correspondence with the bottom wall ... of the vessel, and expediently spaced therefrom."

- New ("foil heating element" and "fitted to the tub" are not disclosed in EP...)
- Inventive step (technical effect: lower water level in the tub is possible)

# Claim to protect the invention

## Claim to be filed:

"A washing machine with **a foil heating element** for heating a medium inside the tub of the washing machine, wherein the heating element **is fitted to** and adapted in its shape to the tub."

# Use of dependent claims to improve protection

**An independent (broader) claim helps prevent the patent from being circumvented.**

**Dependent (more specific) claims are tailored to fit exactly to potential infringing products.**

**Main claim**

```
graph TD; A[Main claim] --- B[Specific claim A]; A --- C[Specific claim B];
```

**Specific claim A**

**Specific claim B**



# Application filed with the EPO

## Claim 1:

A washing machine with **a foil heating element** for heating a medium inside the tub of the washing machine, wherein the heating element **is fitted to** and adapted in its shape to the tub.

**Claim 2:** The washing machine of claim 1, characterised in that the foil heating element is glued to the inside of the tub.

**Claim 3:** The washing machine of claim 1, characterised in that the foil heating element is an integral constituent of the tub and has been formed in the tub during injection moulding thereof.

The EPO will perform its own prior art search and then consider whether the invention **AS CLAIMED** is new and non-obvious.

# Additional prior art found by the EPO

## "Heating device for a household appliance"



Die folgenden Angaben sind den vom Anmel-

54 Heizeinrichtung für ein Haushaltsgerät

57 Bei einer Heizeinrichtung für ein Haushaltsgerät ist zwischen einer zu beheizenden Fläche 2 des Geräts und einer elektrisch leitenden Heizfolie 1 als elektrische Isolation eine keramikgefüllte Polymerschicht 3 angeordnet.

[0022] Beim Ausführungsbeispiel nach Fig. 4 weist die Heizeinrichtung zusätzlich ein wärmeleitendes, metallisches Formteil 6, beispielsweise Aluminium-Formteil, auf, das der zu beheizenden Fläche, im Beispielsfall dem Bottich 7 einer Waschmaschine, angepasst ist.

[0023] Zwischen dem Isolations-Formkörper 4 und dem wärmeleitenden Formteil 6 liegen die Heizfolie 1 und die Polymerschicht 3, wobei die Polymerschicht 3 zwischen der Heizfolie 1 und dem wärmeleitenden Formteil 6 vorgesehen ist. Durch die Klebeeigenschaften der Polymerschicht 3 sind das Formteil 6 und die Heizfolie 1 miteinander verklebt. Auch der Isolations-Formkörper 4 kann mit der Heizfolie 1 verklebt sein. Er kann jedoch auch – ähnlich wie bei Fig. 3 – an die Heizfolie 1 gedrückt sein.

Fig. 4

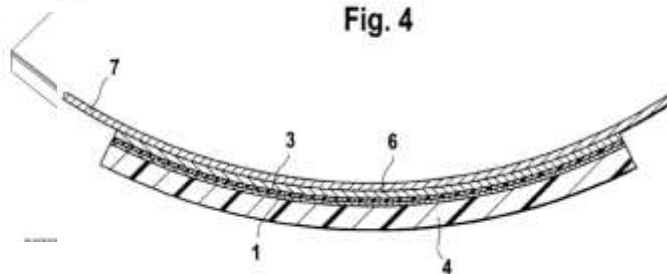

DE 100 25 539 A1:

"Heating device ... comprising a foil heating element (1) ... adapted and attached to a tub (7) of a washing machine ..."

# The opinion of the EPO

DE 100 25 539 A1

## Applicant's claim:

"A washing machine with a **foil heating element** for heating a medium inside the tub of the washing machine, wherein the **heating element is fitted to and adapted in its shape to the tub.**"

Heating device ... comprising a foil heating element (1) ... adapted and attached to a tub (7) of a washing machine ...

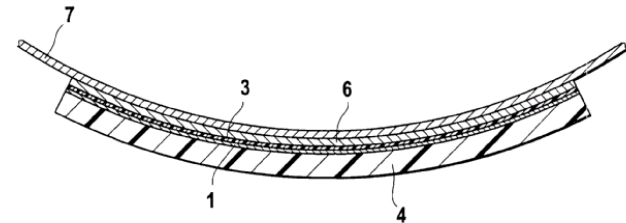

This is already shown in  
DE 100 25 539 A1

## EPO response:

**Please amend your claims if you want your invention protected!**

# Further analysis

Did the EPO overlook any important features of the invention?

Applicant's reply:

Amendments to the application, explanation of the relationship between the invention and the prior art

**How can the claims be amended** to reflect the invention in such a way that it is new (considering all the prior art)?

# Comparison of the invention with the prior art

	EP 0 352 499 A2	DE 100 25 539 A1
Technical features of the invention		
Adapted in its shape to the tub	✓	✓
Foil heating element	No	✓
Glued to outside of tub	No	✓
During injection moulding	No	No
Advantages/technical result		
Compact + excellent heat transfer + easy assembly with fewer parts	No	No

# Result of the analysis

**It is known** in the prior art to fit and adapt a foil heating element to the bottom of the tub of a washing machine.

However, the present invention suggests that the foil heating element can be formed in the tub during the injection moulding of the tub.

This particular way of fitting the foil heating element to the tub is **not known** and produces **new, unique benefits**.

There is no hint in the prior art to take a foil heating element and to form it in a tub during injection moulding of the tub.

→ The inventive step requirement is fulfilled!

The claim must be changed to distinguish it from DE 100 25 539 A1.

# New claim

"A washing machine with a foil heating element for heating a medium inside the tub of the washing machine, wherein the heating element is fitted to and adapted in its shape to the tub, characterised in that the foil heating element is an integral constituent of the tub and has been formed in the tub during injection moulding thereof."

# The original description filed with the EPO supports the amendments to the claims

The **object of the invention** is to provide an electrical heating device for a domestic appliance ... cheap ... easy to assemble ... requires less space ... offers the possibility of reducing energy and water consumption.

... the foil heating element allows a very compact arrangement ... at the same time ... an optimal heat transfer ...

... the foil heating element is integrated during the production of the tub, for instance during the injection moulding ... requires only a few production steps; it does not require complex tools, either ...

Supports inventive step: different technical result

Claim 3: The washing machine of claim 1, characterised in that the foil heating element is an integral constituent of the tub and has been formed in the tub during injection moulding thereof.

Difference to prior art



# The patent is finally granted

Response from EPO: granted!

(19)		
		(11) EP 1 342 827 B1
(12)	<b>EUROPÄISCHE PATENTSCHRIFT</b>	
(45)	Veröffentlichungstag und Bekanntmachung des Hinweises auf die Patenterteilung: <b>09.04.2008 Patentblatt 2008/15</b>	(51) Int Cl.: <i>D06F 39/04</i> <sup>(2006.01)</sup> <i>A47L 15/42</i> <sup>(2006.01)</sup>
(21)	Anmeldenummer: <b>03005120.5</b>	
(22)	Anmeldetag: <b>07.03.2003</b>	
(54)	<b>Elektrisch beheizbares Haushaltgerät</b> Electrically heatable household appliance Appareil ménager chauffé électriquement	
(84)	Benannte Vertragsstaaten: <b>AT BE BG CH CY CZ DE DK EE ES FI FR GB GR HU IE IT LI LU MC NL PT RO SE SI SK TR</b>	(72) Erfinder: <ul style="list-style-type: none"> <li>• Bolduan, Edwin 13629 Berlin (DE)</li> <li>• Stolze, Andreas, Dr. 14612 Falkensee (DE)</li> <li>• Wiemer, Horst 14532 Kleinmachnow (DE)</li> </ul>
(30)	Priorität: <b>07.03.2002 DE 10209975</b>	
(43)	Veröffentlichungstag der Anmeldung: <b>10.09.2003 Patentblatt 2003/37</b>	
(73)	Patentinhaber: <b>BSH Bosch und Siemens Hausgeräte GmbH</b> <b>81739 München (DE)</b>	(56) Entgegenhaltungen: <b>EP-A- 0 352 499</b> <b>DE-A- 10 025 539</b> <b>DE-A- 19 935 987</b> <b>DE-U- 1 823 414</b> <b>US-A- 5 444 228</b>

# Thank You for Your Attention!

**Siyoung Park**

Counsellor, Innovation Division, WIPO

[siyoung.park@wipo.int](mailto:siyoung.park@wipo.int)