



商标和工业品外观设计等国际 保护体系

International Registration Systems
for Trademarks and Industrial
Designs

WIPO/MOST
11. 2003



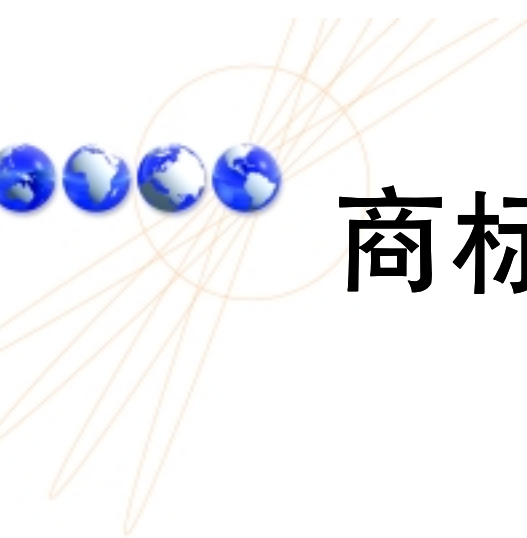

商标和工业品外观设计等 国际保护体系

- WIPO管辖的条约+其他国际条约
 - 巴黎公约 (1883), TLT (1994),
 - 马德里协定 (1891), 海牙协定 (1934)
- 区域性条约(EU,OAPI等)





马德里国际商标体系



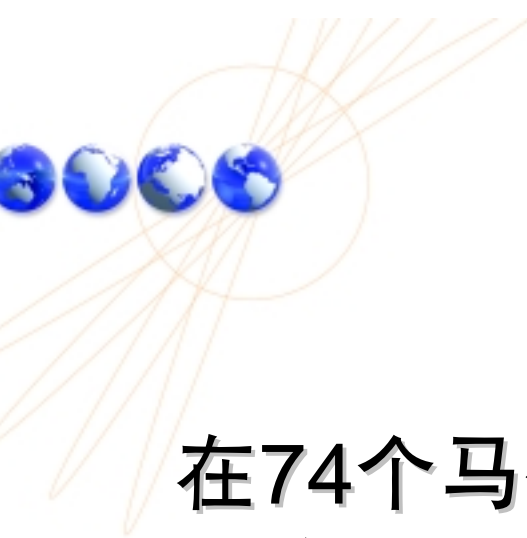

优越性

在74个马德里联盟国家的商注册和管理的通一程序

填写一份申请，使用一种语言(英语或法语)，缴纳统一注册费，向一个机构提出申请。



马德里联盟的现状(2004年10月23日)

(74 国家)

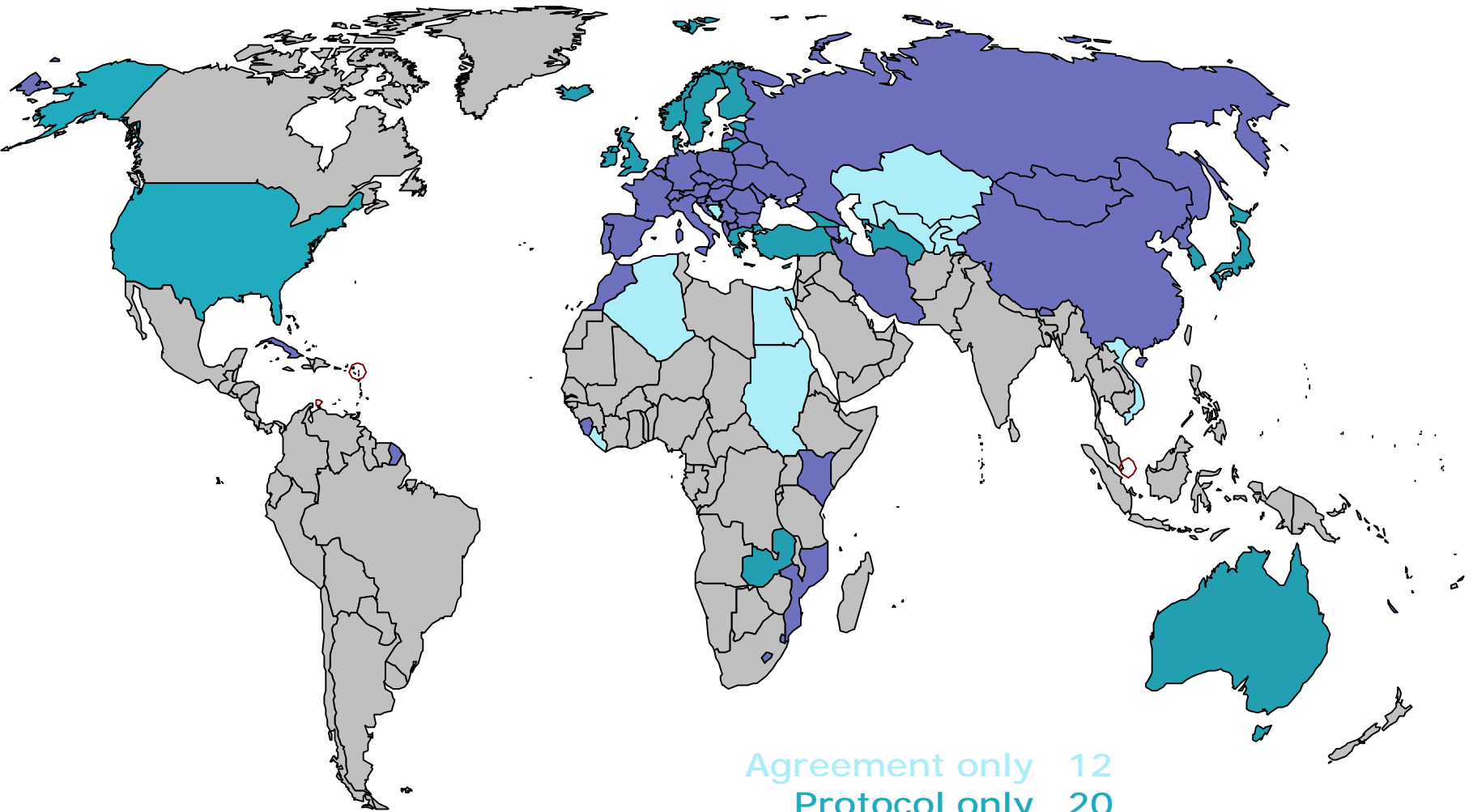

Agreement only	12
Protocol only	20
Agreement and Protocol	42

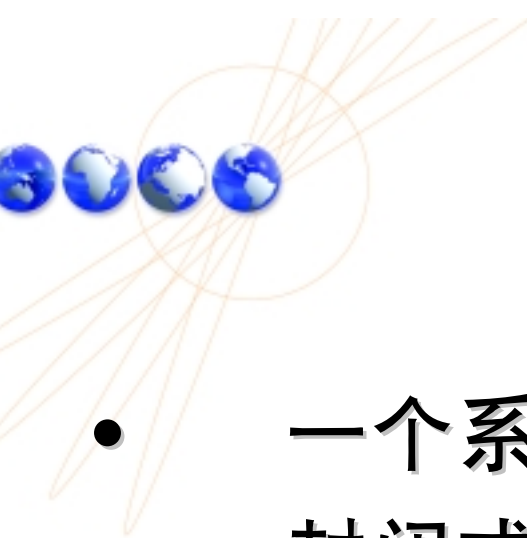

基本特征

- 一个系统 - 两个条约
- 封闭式的系统
- 以国家申请或注册为基础
- 独立性/中心攻击
- 如同国家申请或国家注册
- 后期领土延伸
- 统一管理



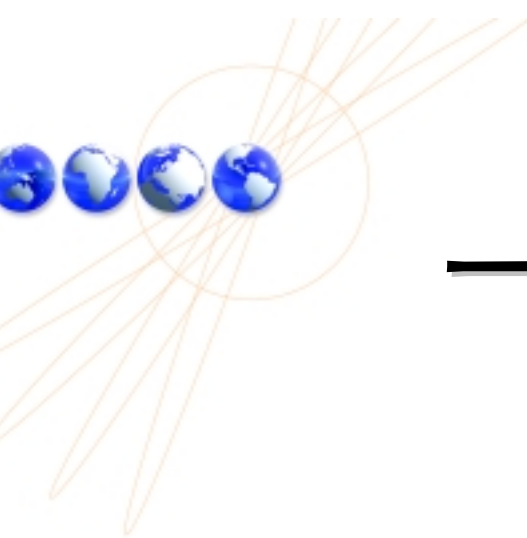

一个系统 - 两个条约

- 商标国家注册马德里协定 (1891)
- 与协定相关的议定书 (1989)



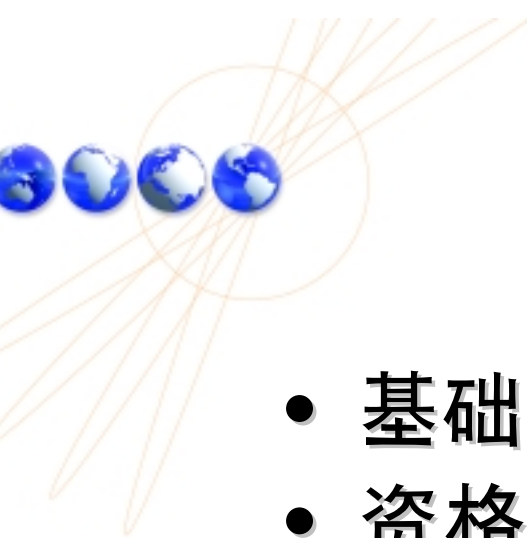

比较

- 基础申请(A) 和基础注册 (P)
- 资格 (A：瀑布式)
- 语言 (A：法语 P：英语法语)
- 驳回保护的期限 (12或18月)
- 费用(A：统一规费，P：亦可单独规费)
- 转变(P)
- 区域性体系 (P)
- 保护条款



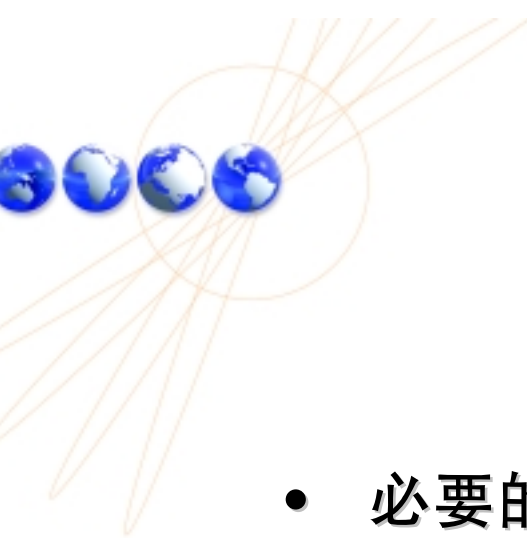

封闭式的系统

- 必要的联系
 - 营业所 (真实有效)
 - 住所
 - 国籍

- 原属局



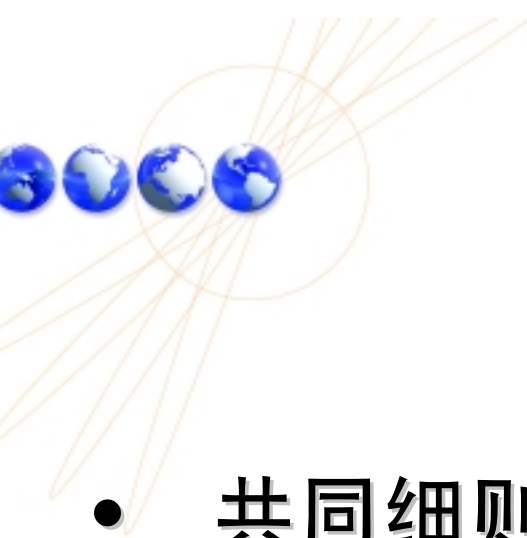

同一份申请

- 共同细则
- 国际申请
 - 依照协定
 - 依照议定书
 - 依照协定和议定书
 - 在指定国家的效力
 - 一束权利





依附性

- 自国际注册之日起五年内依附于基础商标
- 受中心打击的可能



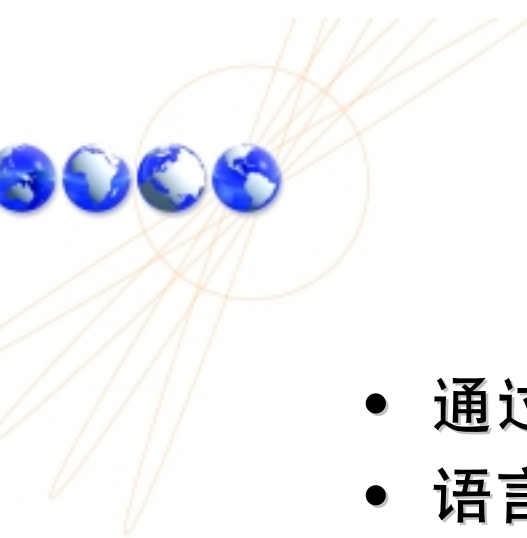

间接申请

- 通过原属局
- 语言
- 形式审查
- 资格的确认
- 注册
- 通知及公告
- 被指定国驳回的可能行





效力：国家权利束 注册期10年

- (指定)国家局决定
 - 保护的实质行条件
 - 驳回时的适用程序
 - 保护范围





可注册后扩大缔约保护范围

- 不能超过注册范围, 但可以删减商品或服务
- 保护期与国际注册同期
- 不断延伸的可能性





中心管理

- 转让
- 变更姓名和地址
- 删减，放弃，注销
- 续展



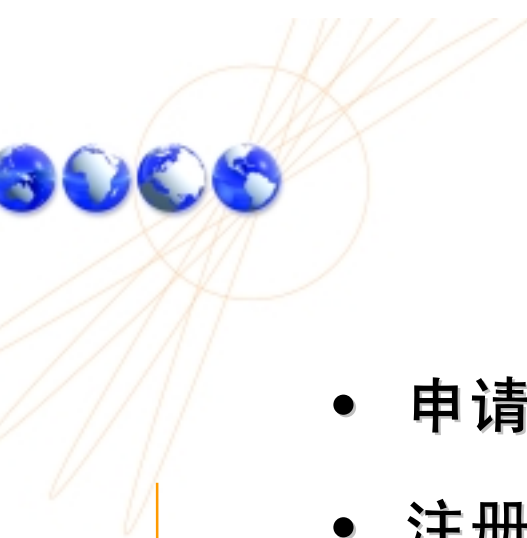

2002年

- 申请 23,145
 - 注册 22,236
 - 续展 6,203
 - 后期指定 6,090
 - 变更 46,722
 - 驳回 100,281
- 至2002底, 国际注册总数为 400,000
(= some 450万国家注册)



2002

Enregistrements par pays d'origine *Registrations by Office of Origin*

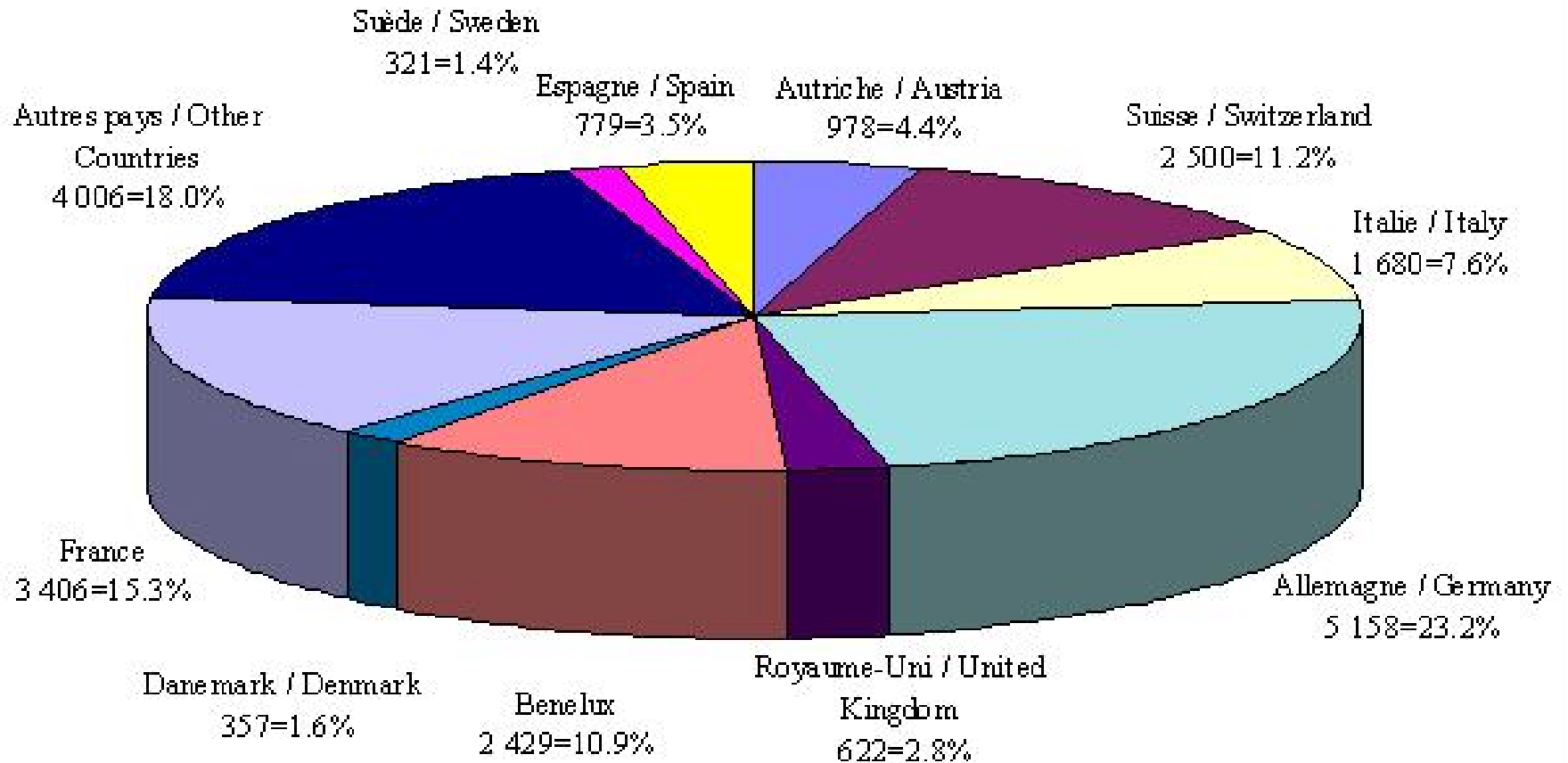

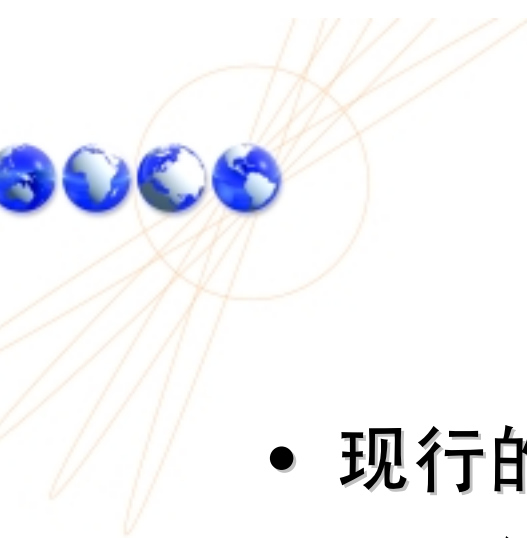

现状

- 现行的共同细则于2002年四月一日修订
 - 更便于使用
 - 便于于国际局的直接联系
 - 删减
 - 变更注册人
 - 登记使用许可
 - » 两此付费
- 自2004年四月一日起， 西班牙语成为新的工作语言



European Union

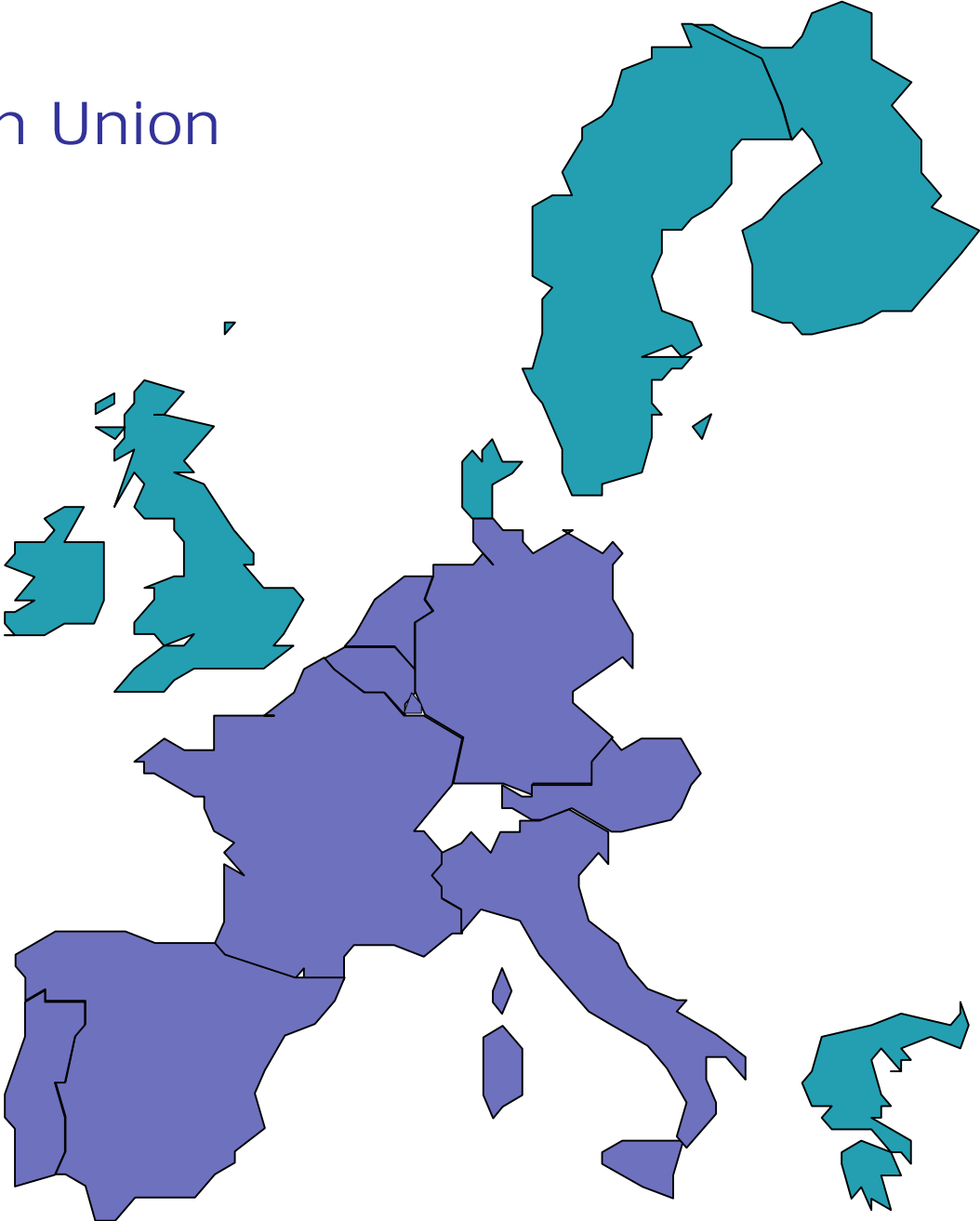

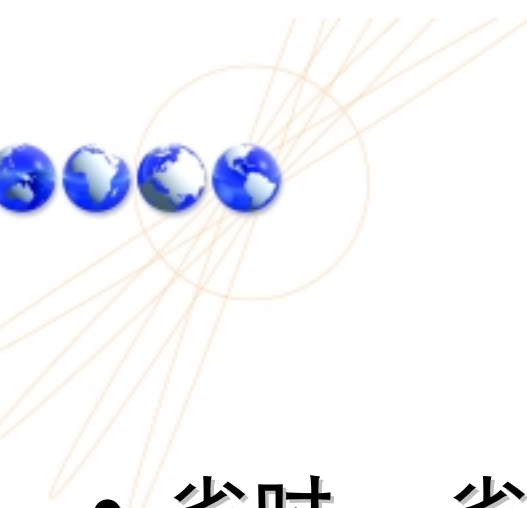

马德里国际商标体系

- 省时，省力，省钱
 - <http://www.wipo.int/madrid/en/forms/index.htm>
- 省钱
 - <http://www.wipo.int/madrid/feecalc/FirstStep>





如何商标国际申请？ 74国成员

- 向原属局直接申请
- 需要在原属国先申请或注册
- 申请语言：英语或法语
- 统一缴费 (瑞士法郎)



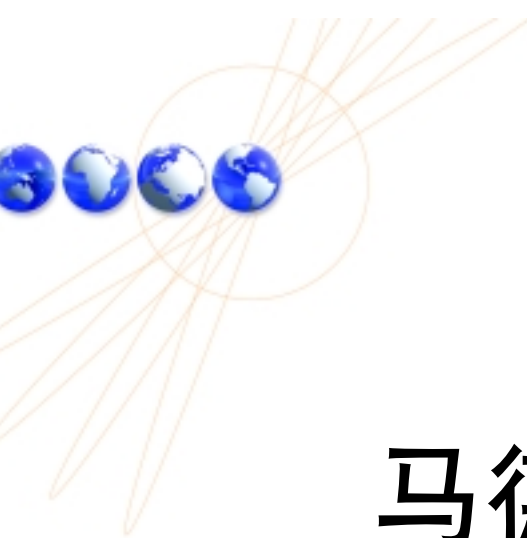

马德里国际商标体系

<http://www.wipo.int/madrid/en/index.html>

谢谢大家





海牙国际外观设计注册体系



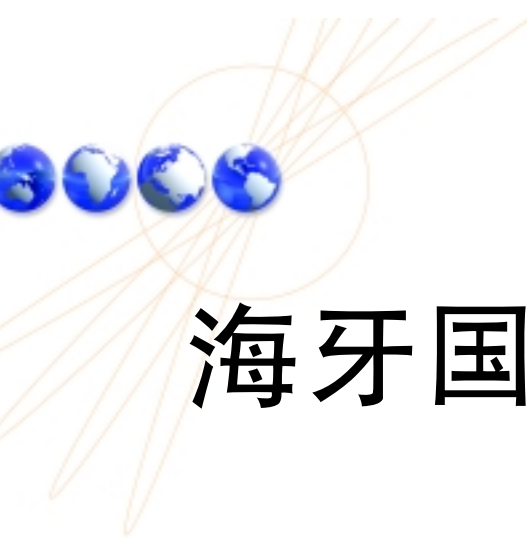

海牙国际外观设计注册体系

海牙协定的基本概念

海牙体系的应用





通常的国家申请程序

- 申请书
- 填写及准备
- 代理
- 使用权利要求&说明
- 发明人证明
- 翻译
- 文件的公证&认证
- 各种费用

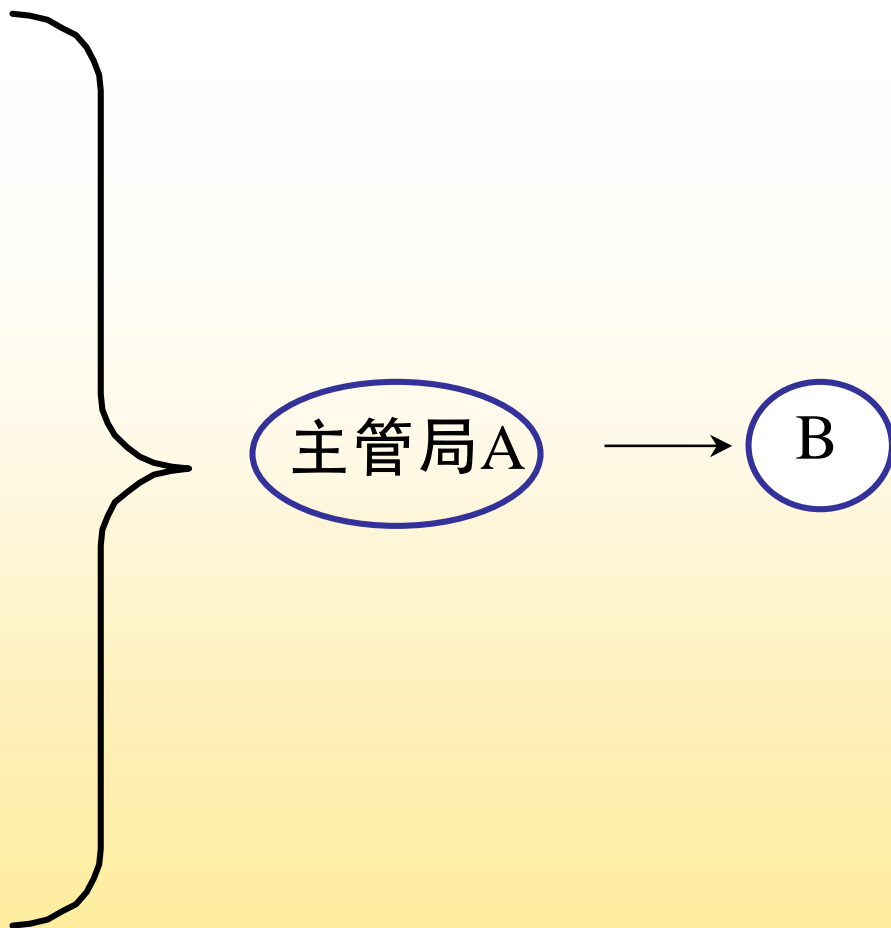

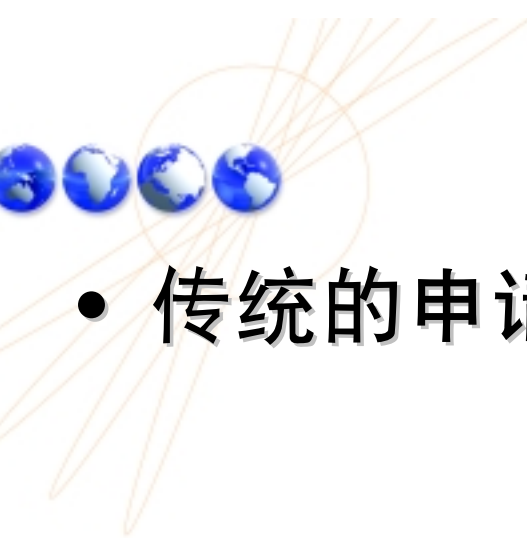

• 传统的申请概念 - 地域性 = 多重申请

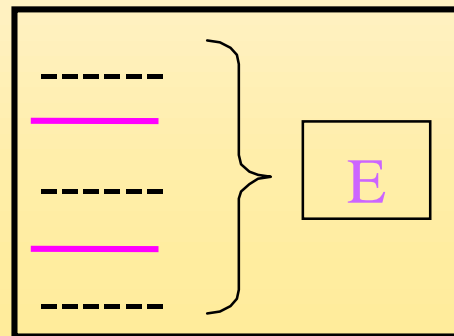
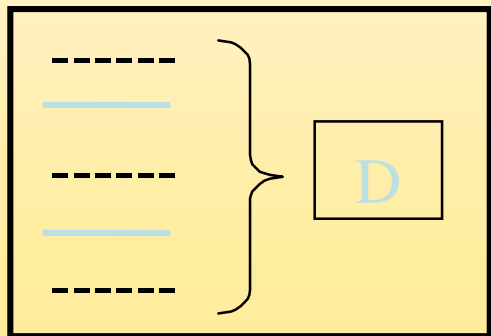
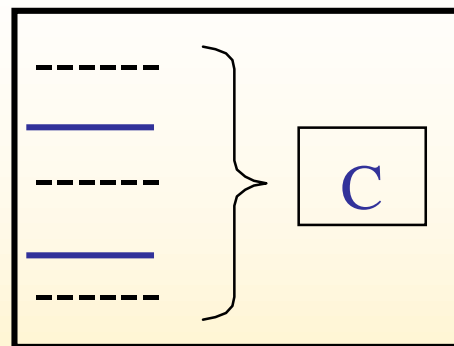
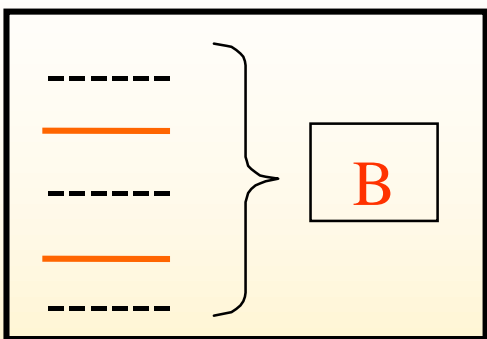

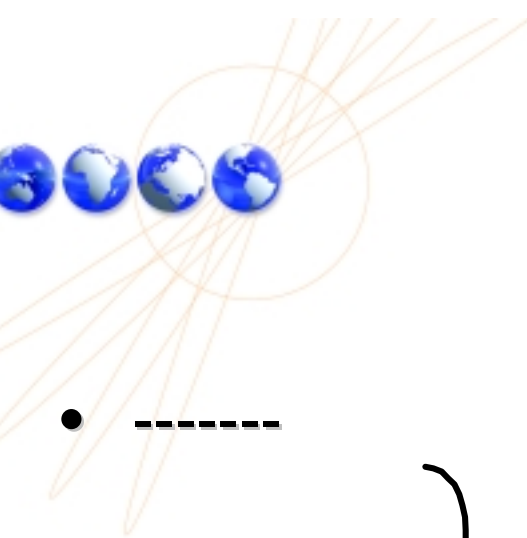

海牙体系的原则

- -----
- -----
- -----
- -----



WIPO

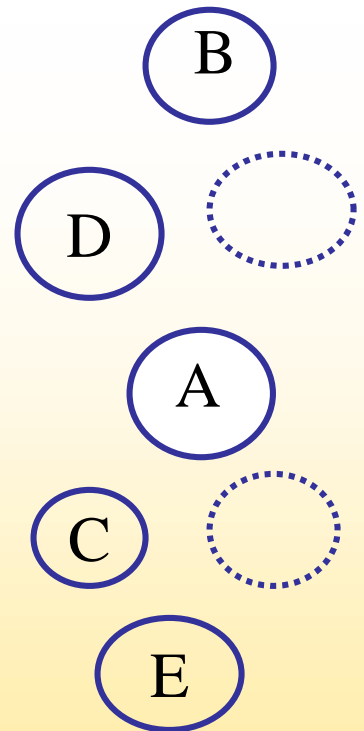

一份申请取得工业品外观设计在多国注册

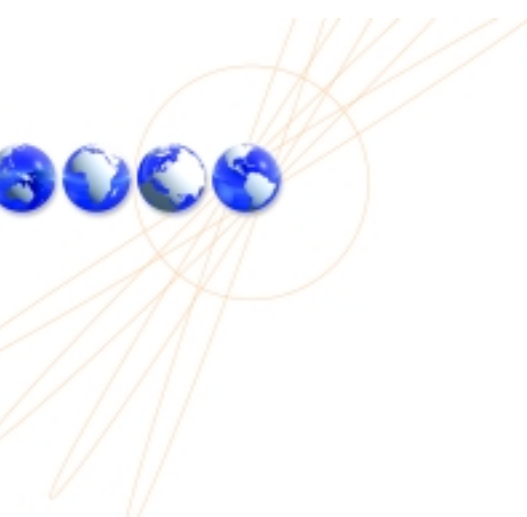

海牙协定成员国

共34 个国家

<http://www.wipo.int/treaties/documents/english/word/h-hague.doc>



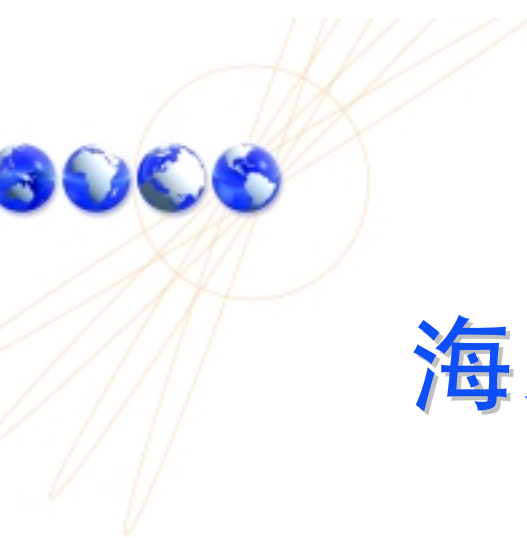

海牙协定的基本概念

- 谁可以申请 (封闭式的系统)
 - 营业所 (真实有效)
 - 住所
 - 国籍





海牙协定的基本概念(1)

(1960 Act)

如何申请？

- 向国际局直接申请
- 不需要在原属国先注册
- 申请语言：英语或法语
- 不需代理
- 统一缴费



海牙协定的基本概念(II)

国际局的工作？

- 形式审查
- 注册
- 公布
- 通告指定国

国际注册的效力？

- 在该国家的直接国家申请或注册





海牙协定的基本概念(III)

指定国 IP 局的工作？

通常的审查工作。



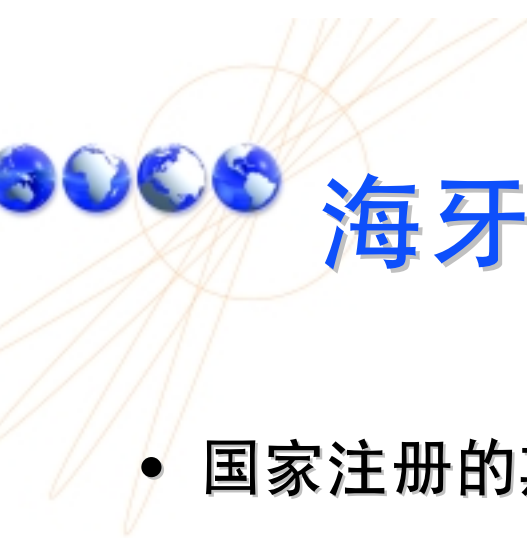

海牙协定的基本概念 (IV)

- 国家注册的期限？
 - 保护期 5 years, 以5 为一年续展；可续展到国家法律规定的期限
- 优越性？
 - 先进的程序条约，便于取得权利，亦利于管理



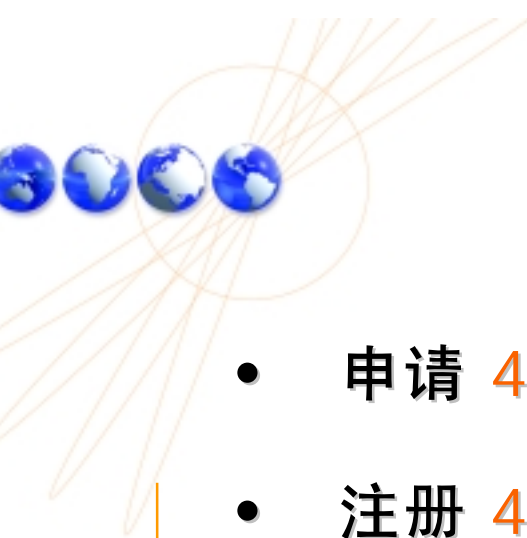

2002年

- 申请 4,284
- 注册 4,177
- 续展 3,302
- 变更 3,466

99% 的申请直接向国际局递交

至 2002年底, 有效国际注册 36,000

(= some 400,000 国家注册)

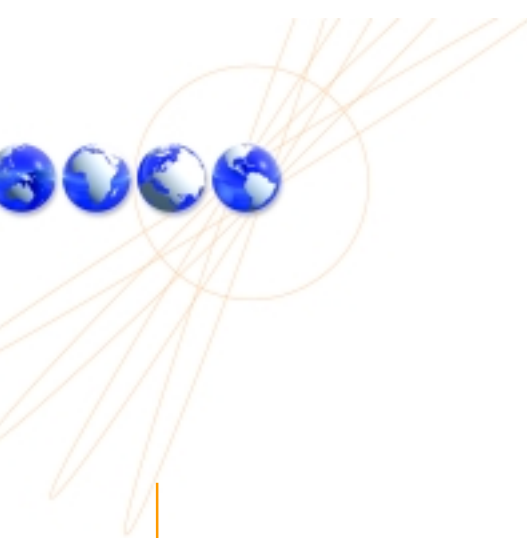

2002年的主要用户

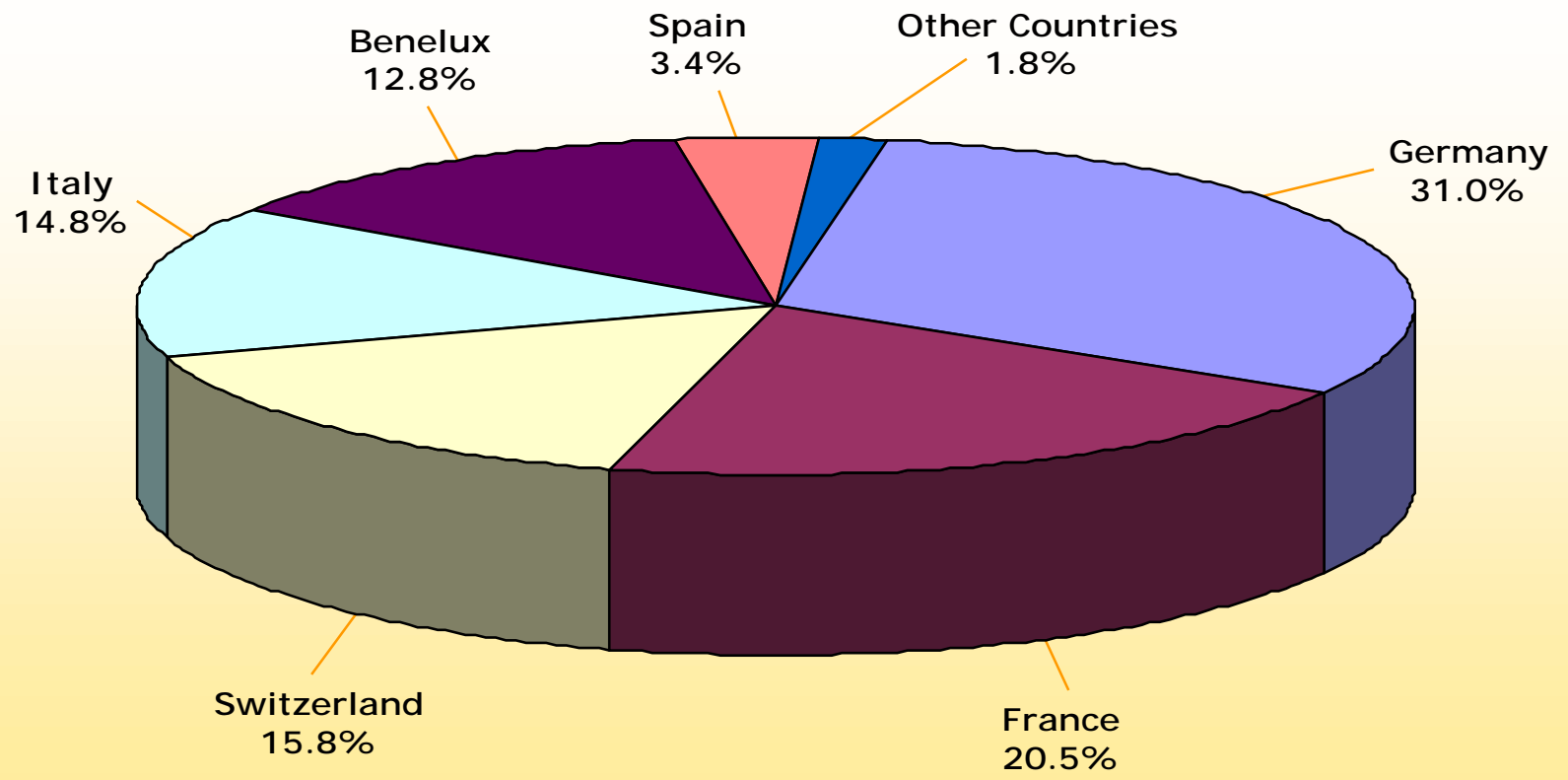



11 % in Class 6 : 家具



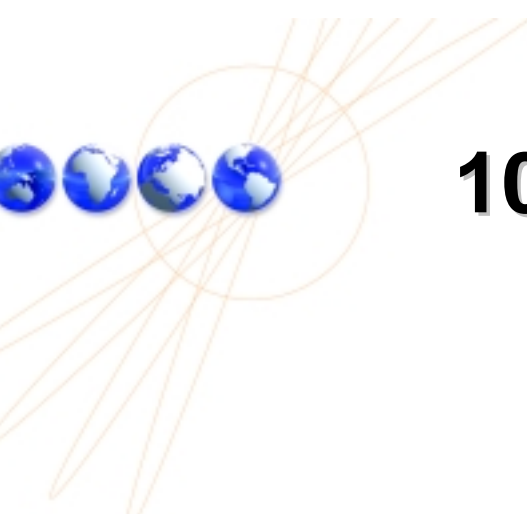

10% in Class 9 : 包装

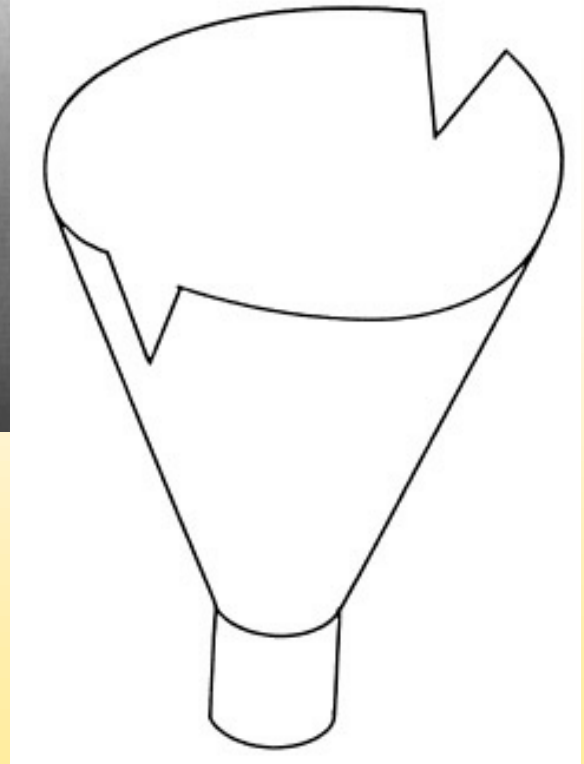
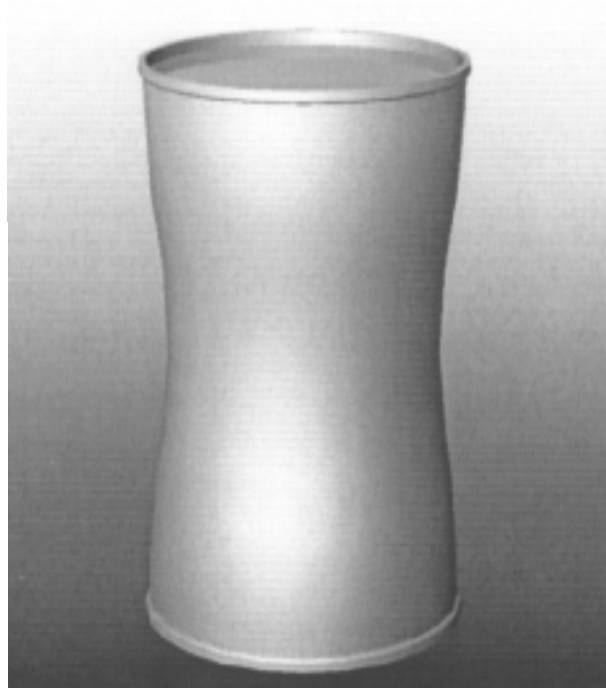



9 % Class 10 : 计时器





7 % in Class 7 : 日用品

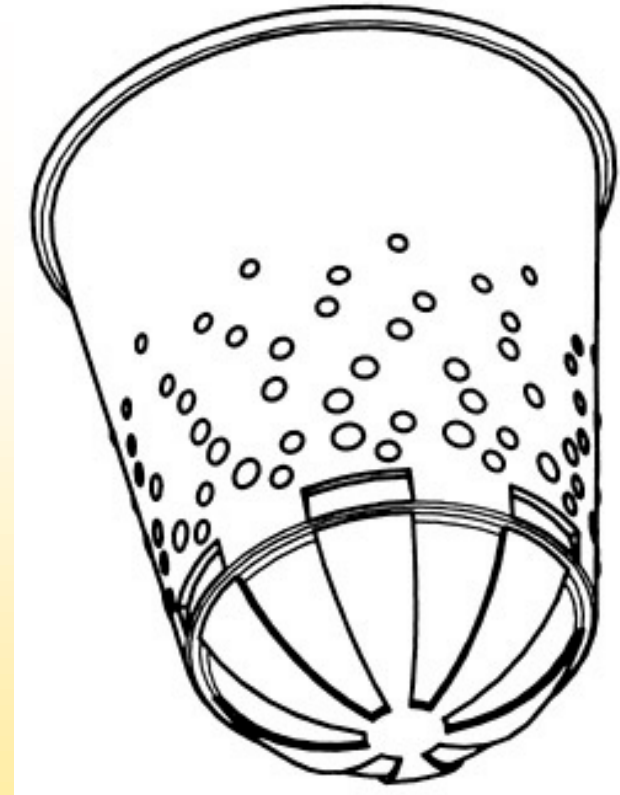

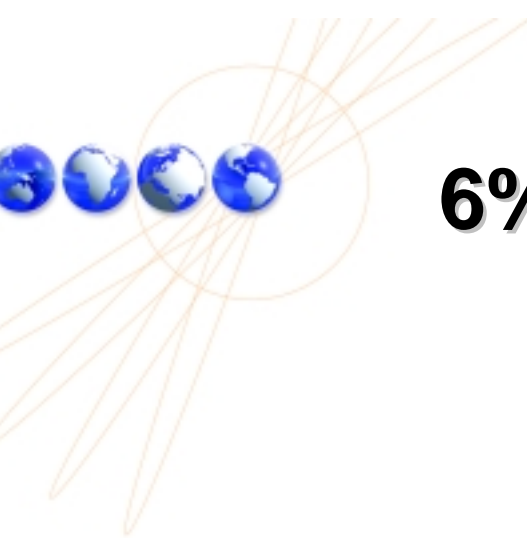

6% in Class 23 水暖管道

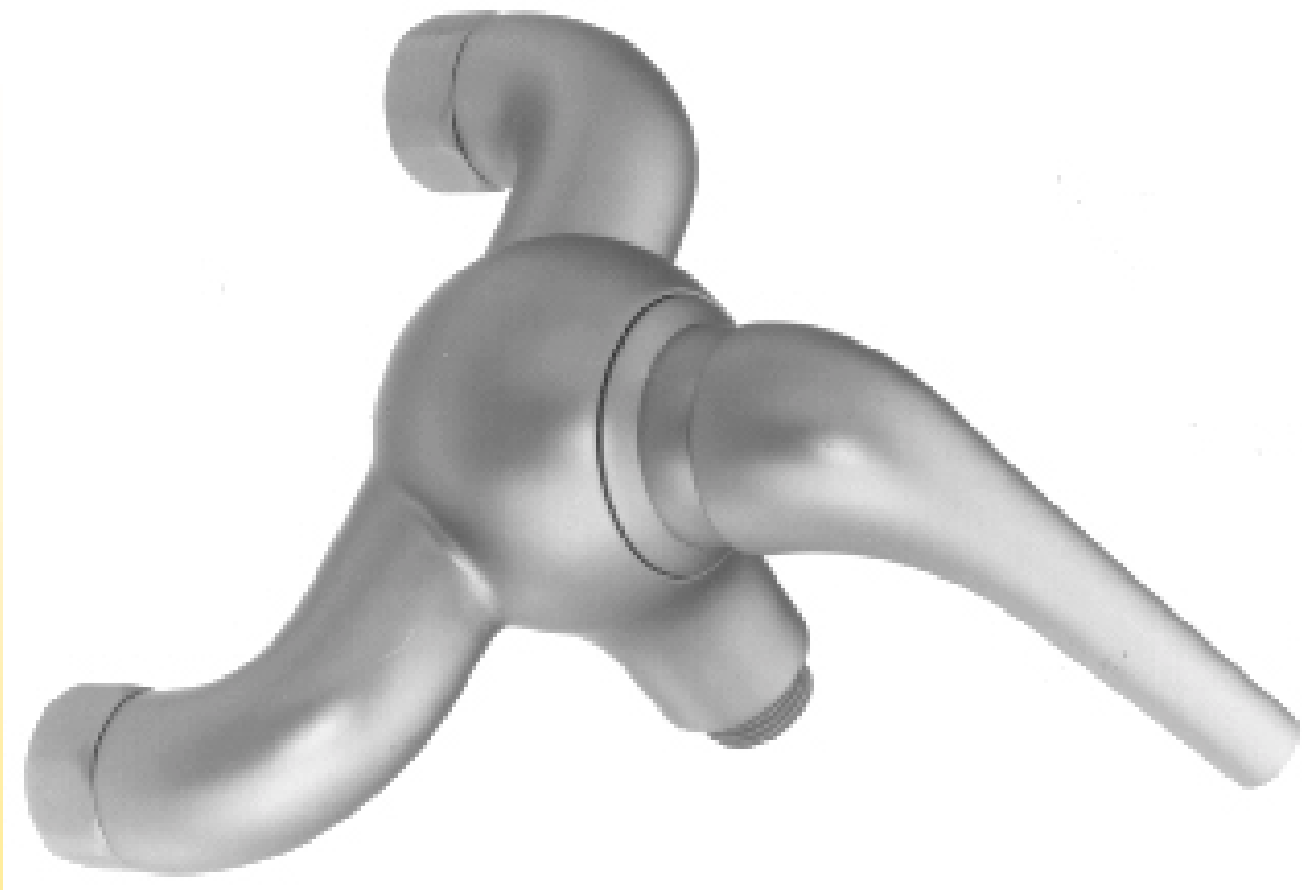



5% in Class 12 : 运输工具

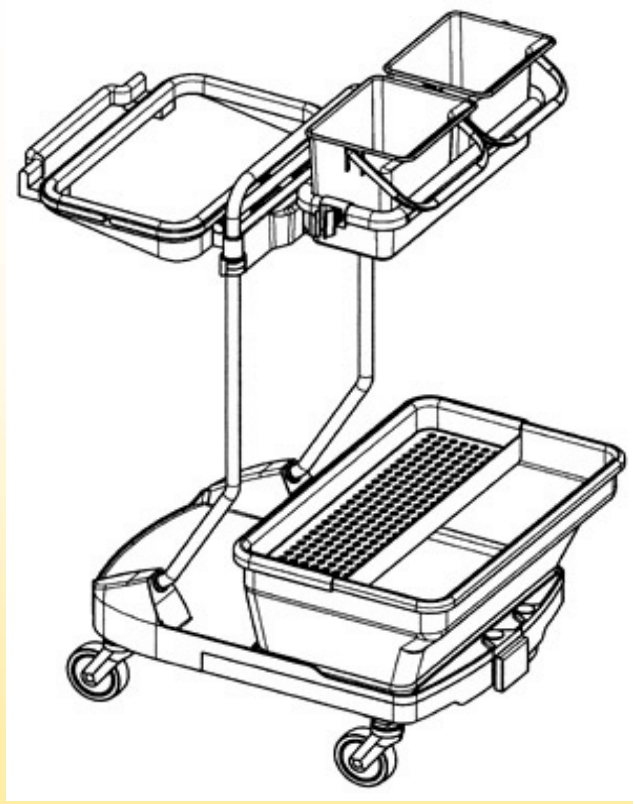
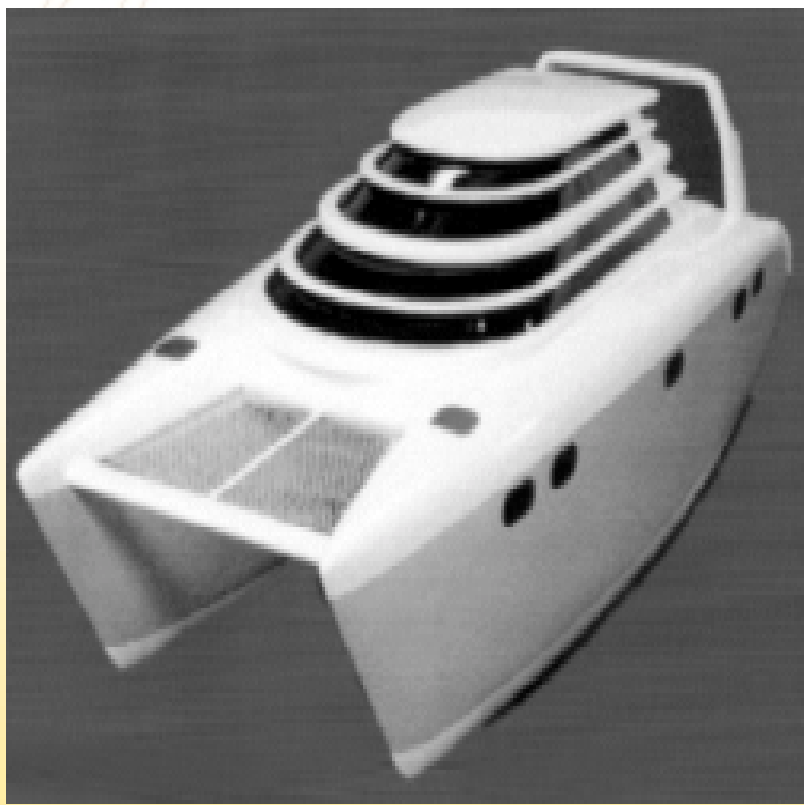

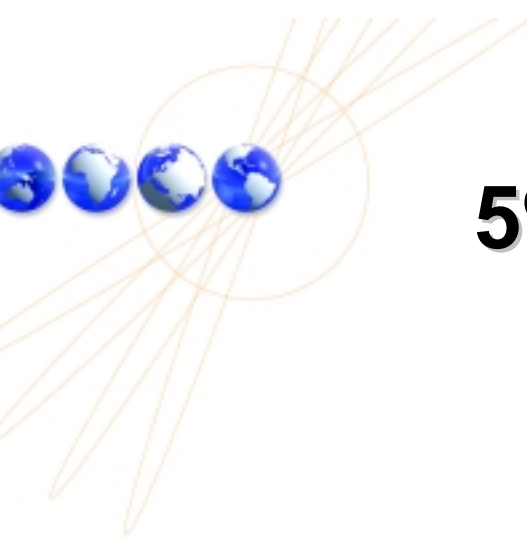

5% in Classes 2 and 5

服装和纺织品

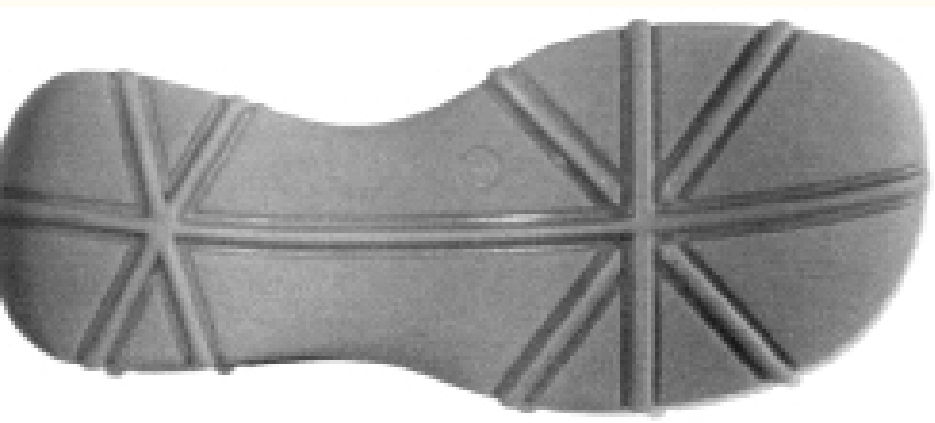

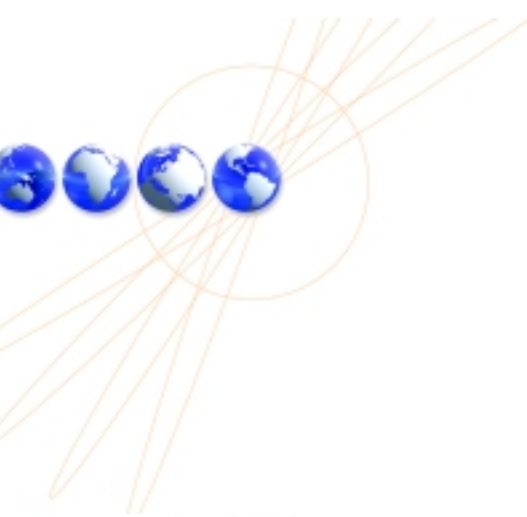

5% in Class 11 装饰品





4% in Class 23

电器

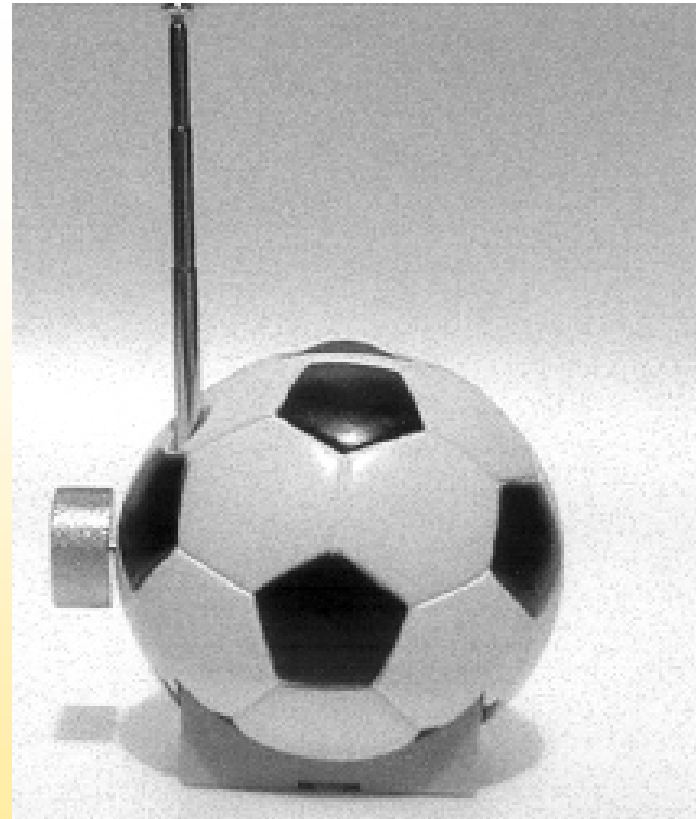
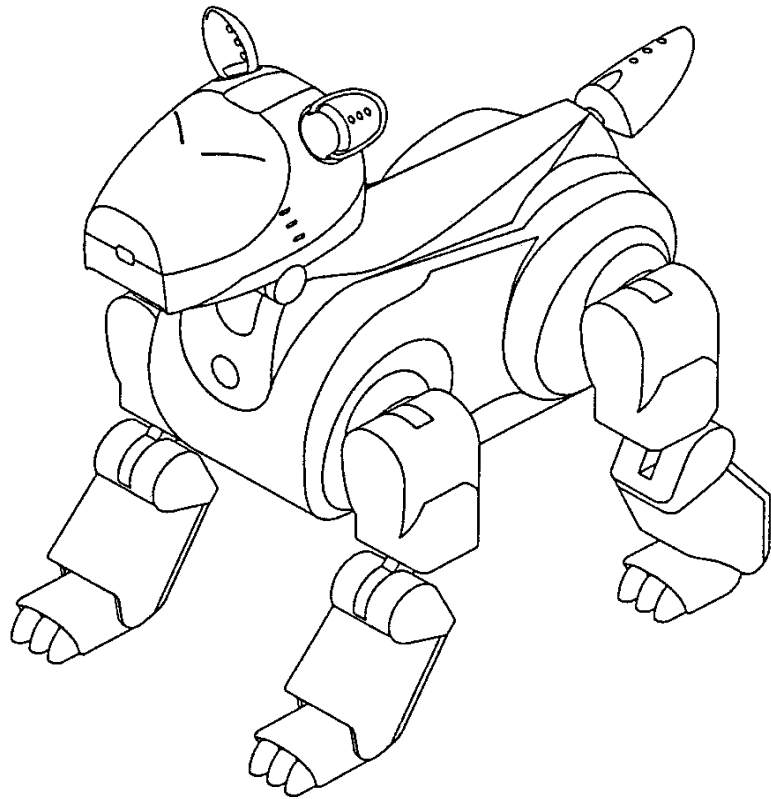



海牙国际外观设计注册体系

- 对用户的好处：
- 对国家局的好处：
 - 免除形式审查，公告，注册
 - 分红



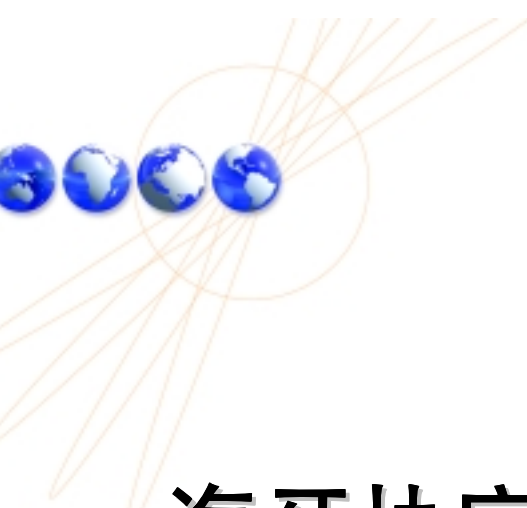

其他

- 海牙协定的局限性
- 海牙协定日内瓦议定书
- 加入海牙联盟：那个文本？
- 参考材料：
- <http://www.wipo.int/hague/en/index.html>



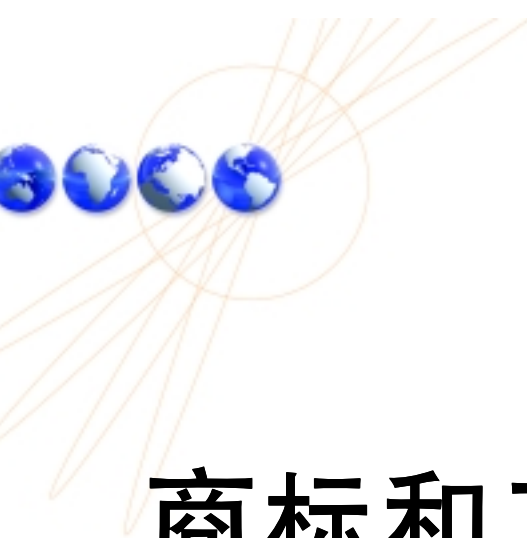

商标和工业品外观设计等国际 保护体系

谢谢大家
再见

11. 2003

