

# CLIENT'S PERSPECTIVE HOW PRIVILEGE PLAYS A ROLE



Hans Blöchle, Head Global IP  
Schindler Management Ltd.  
hans.bloechle@ch.schindler.com



## Client attorney privilege (CAP) in Intellectual Property (IP)

CAP is about:

### **Individual scientific / technical interpretation of rights.**

- No other field besides IP where technical background is that frequent and necessary, therefore not incorporated in civil law, but should be entered in patent law.
- Conventions needed in case of multiple litigation parallel in different jurisdictions, especially if countries with extensive discovery are involved.

CAP is not about:

### **Representation before national courts.**

### **Disclosure or holding back of facts like prior art.**

- Prior art exists independently of what the other side knows.

Inventions are **inter-national** by nature, like natural sciences and technology.  
IPR are **national** by legal nature.

# Typical inquiry from Research & Development (R&D) to in-house patent advisors

This is our new design:

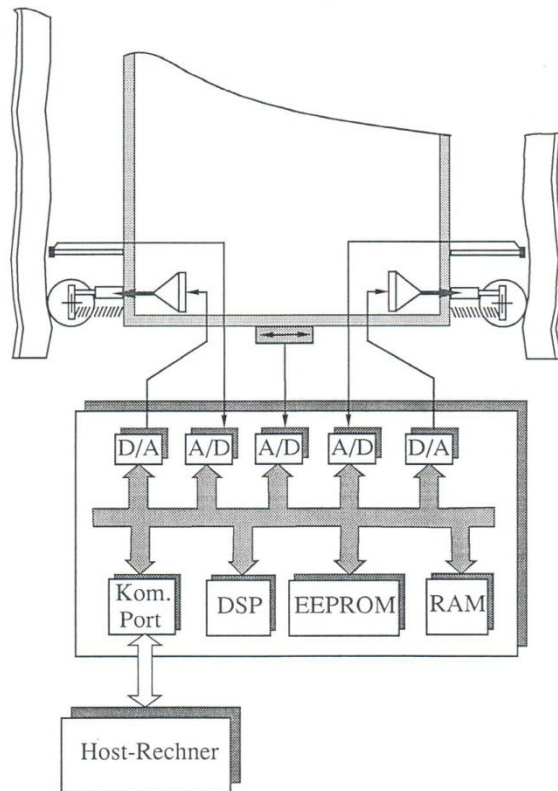

This is protected by a granted patent:

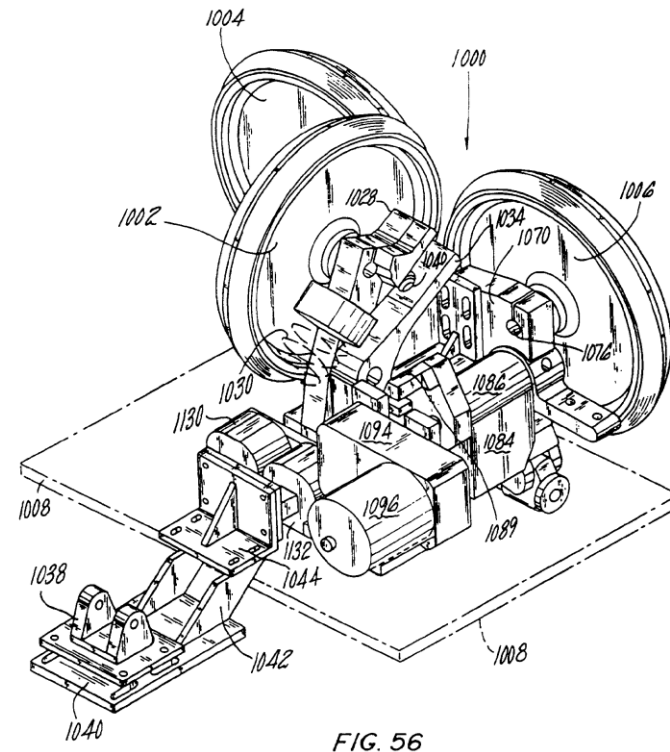

**Can we go to market?**

## A typical patent claim, describing “Active Ride Control”

1. **An elevator car including apparatus for stabilizing the elevator car** (10; 46; 250; 1144; 1804) in a hoistway, the apparatus comprising:  
an **accelerometer** (16; 50-54; 204-208; 252-256; 1150), responsive to a horizontal acceleration of the car, for providing a sensed signal having a magnitude indicative thereof; and

**control means** (20; 380; 532; 1154) responsive to the sensed acceleration signal for controlling **actuator means** (24; 210-216; 240-244; 1146, 1148, 1300, 1302) for horizontally actuating the car against the acceleration; characterised in that the apparatus further comprises:

**position sensing means** (440-454- 634-648; 1376, 1378), responsive to the degree of centering of the car, for providing a **sensed signal** having a magnitude indicative of a horizontal position of the car; and in that

when supplying the acceleration signal to the actuator means, the control means is also responsive to the signal from the position sensing means, thereby to compensate for components of the acceleration signal not representative of the actual horizontal acceleration acting on the elevator car and to **compensate for forces acting on the car tending to decentre it.**

# COMMON LAW

pre-trial discovery

# CIVIL LAW

no fishing for evidence

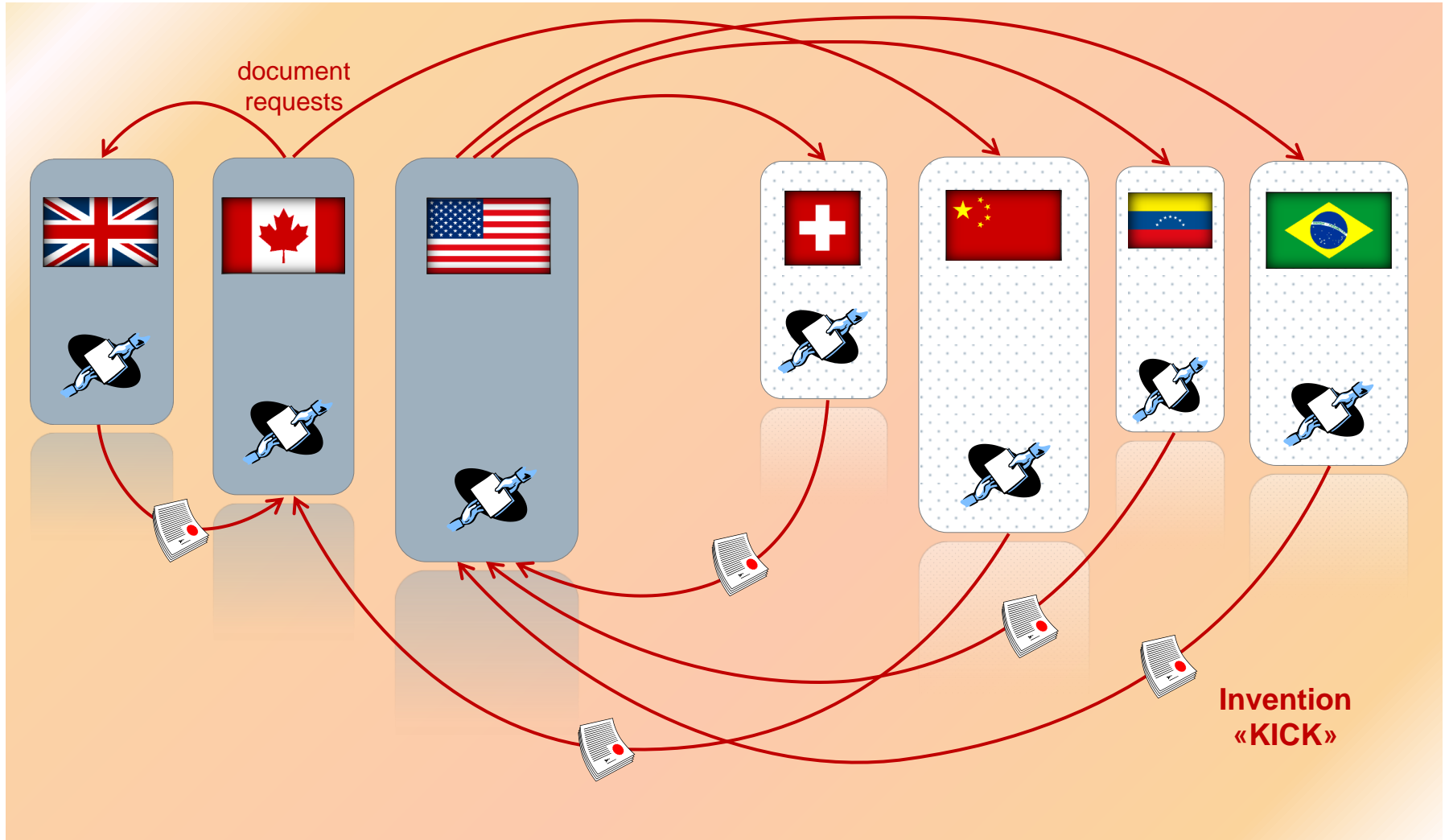

## Example for missing CAP

### B. Schindler NJ Must Responde To Questions Seeking Non-Privileged Testimony

█ seeks to compel Schindler NJ employee Frank Resch, a non-lawyer, to answer certain questions posed in his deposition on March 23, 2010. █ asked questions about Schindler NJ's reasons for choosing to use one belt design rather than another in the United States. Schindler NJ's counsel instructed Mr. Resch not to answer on the basis of privilege. The conversations at issue were between non-lawyers. The record cannot support Schindler NJ's claim of privilege:

Q. With whom have you had those discussions?

A. This is, again –

MR. YANNEY: You can answer the who, but don't reveal any of the substance of that may have been discussed.

THE WITNESS: Okay.

A. Inventio, Mr. Bloechle and the CTO.

Q. What is Mr. Bloechle's job at Schindler?

A. He is head of Inventio.

(Ex. 6, Resch Dep. at 16:8-10)

Mr. Bloechle is a European patent agent, not a lawyer. Communications with a patent agent are not entitled to attorney-client privilege under Swiss law. *See In re Rivastigmine Patent Litig.*, 239 F.R.D. 351, 359 (S.D.N.Y. 2006)

## Examples of Advisor's documents to be protected by CAP

### Defense Strategy <sup>1)</sup>

1. Non-infringement
  - 1.1. Feature 3.1 not realized, because bolt 13 is missing.
  - 1.2. Feature 6 = inadmissible amendment (Art. 123 EPC)
  - 1.3. Do not provide drawing XZ56123 (incorrect material description)
  - 1.4. Attention: Test installation in R&D India including bolt!
2. Invalidity
  - 2.1. File immediately reexamination request before SIPO, Beijing
  - 2.2. File EP search report, including parent application of document 3
  - 2.3. Inequitable conduct – contact ex-employee

<sup>1)</sup> See detailed protocol of strategy meeting on August 30 (attached)

### Cost of defense

Attorney's fees	400'000
Technical Experts	100'000
Meetings, Travel	50'000
Preparation of functional model	50'000
Total	600'000

### Risk assessment

Probability of infringement: <sup>2)</sup>	30%
Circumvention available, cost:	200'000

### Management request

Negotiate settlement up to 300'000.

<sup>2)</sup> See protocol of infringement analysis with S. Ronaldo, R&D



## Example of Court sanction due to non-compliance of party/attorney

In December 2008 Schindler Elevator Corp. of Morristown, the U.S. arm of Switzerland-based Schindler Group, sued **Otis Elevator of Farmington** for U.S. Patent No. 6,739,433 granted to **Otis** for its design of a flat belt used in place of a cable to raise elevators, is invalid.

**Otis** counterclaimed that Schindler's own flat-belt technology infringes on **Otis** patent.

**Otis** also brought a third-party claim against Swiss-based Aufzüge, claiming it provided technical expertise that induced the Schindler US company to violate the patent.

The court decided the entry of default against Aufzüge was an appropriate sanction for directing its counsel to refuse to comply with a court order.

The default is that:

Aufzüge copied **Otis's** invention in the '433 patent.

The elevator systems using Aufzüge belts are commercially successful because of their use of the belts claimed in the '433 patent instead of traditional cables.

Aufzüge unsuccessfully tried to design alternatives to the '433 patent inventions.



## CAP also for in-house advisors

In-house advisors need to be protected by CAP, because they

1. are the first to get in touch with patent conflicts,
2. provide "first aid",
3. contribute industry-specific interpretation,
4. are frequently coordinating multi-national conflicts,
5. make proposals for strategy to the client's management.

Special risks:

Preliminary injunctions, where defendant's quick reaction is required.

Fishing suits, where proceedings are initiated for the purpose to learn about details of competitor's new products.

## Major Risks for Multi-national Defendants

1. Fishing for arguments and strategies among unprotected advisors
2. Discovery among in-house patent attorneys
3. Discovery in R&D sites unrelated to the scope of the patent
4. Serious conflict with national penal code (e.g. CH)

**Single national codes are insufficient, because not respected by foreign courts!**

### **Without International CAP Agreement:**

- Pervasive legal uncertainty for both right owners and defendants.
- Development activities at risk in unprotected countries.