



WIPO | HAGUE

The International
Design System



The role of the Hague Registry: formality examination of international applications, irregularity notifications, and management of international registrations. The role of the designated Contracting Parties: specific requirements, substantive examination, possible refusals of international registrations and follow-up actions

Kateryna Gabriele
Operations Service
The Hague Registry

December 2, 2022

Outline

- Introduction
 - Who and where can file an application
 - How to file an application
- Contents of an application
 - Mandatory
 - Additional mandatory
 - Optional
 - Requirements concerning the reproductions
- Irregularities
- Publication and its deferment
- Effects of international registration
- Refusal and other office actions
- Subsequent management
- Renewal

**Hague Agreement Concerning
the International Registrations
of Industrial Designs**

of November 6, 1925

- I. Hague Act 1960
- II. Complementary Act of Stockholm 1967
as amended on September 28, 1979
- III. Geneva Act 1999

Common Regulations

(as in force on January 1, 2022)
and

Administrative Instructions

(as in force on January 1, 2019)

Treaties



**The Hague
System**

**+ National
laws and
regulations**

WIPO Publication No. 269E/22



2022

Geneva Act (1999)
The Hague Act (1960)
~~**London Act (1934)**~~

Who can file an application

- The Hague System is a closed system
- Link with the Contracting Parties
 - Nationality
 - Real and effective industrial or commercial establishment
 - Domicile
 - Habitual residence (1999 Act)

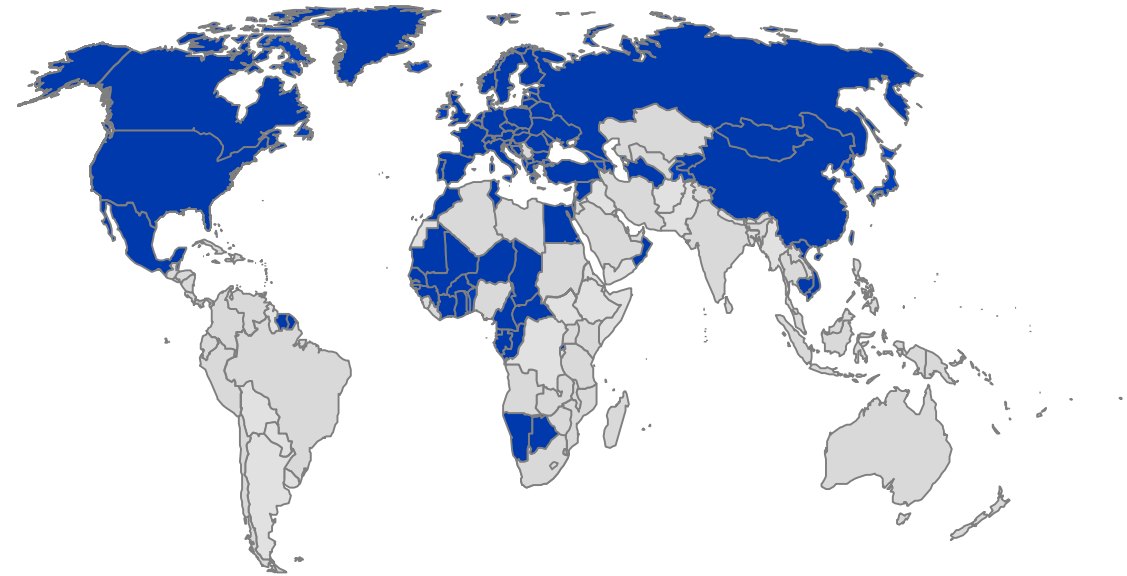

How to file an application

- Directly with IB of WIPO using [eHague](#)
- Or
- Indirectly through the Office of the Contracting Party

Good to know:

- *NO national application is required*
- *It is possible to designate the applicant's Contracting Party*
- *NO subsequent designation*
- *Declarations made by the CP to be taken into consideration*



Contents of application

- Mandatory (Rule 7(3))
- Additional mandatory (Rule 7(4))
- Optional (Rule 7(5))



Contents of application



■ **Mandatory contents (elements needed for filing date (Rule 14(2)))**

- Indication of application (on official form / E-Filing, in English, French or Spanish)
- Data concerning applicant
- Reproductions (for up to 100 designs in the same Locarno Class)
- Designation of Contracting Parties

■ **Mandatory contents (elements not needed filing date)**

- Indication of product
- Payment of fees
- Indication concerning entitlement
- Indication of applicant's Contracting Party (under the 1999 Act)
- Signature

Contents of application

■ Additional mandatory contents

Note: *These elements become mandatory if certain Contracting Parties are designated.*

- Identity of the creator
 - + declaration of inventorship (only for USA)
- Description
- Claim

■ Optional contents: common items

- Description
- Identity of the creator
- Priority claim (Article 4 of the Paris Convention)
- International Exhibition (Article 11 of the Paris Convention)
- Legends



Requirements concerning the reproductions

- ❑ Legal framework
 - ❑ Article 5 (1999Act/1960Act)
 - ❑ Rule 9 of the Common Regulations
 - ❑ Administrative Instructions – Section 401-405

Requirements concerning the reproductions

- 16x16cm (max)
- 3cm (min) at least one of the reproductions
- 5mm left around the reproduction
- Reproductions numbered 1.1, 1.2, 1.3, 2.1, 2.2.....
- Industrial design against a neutral background
- Upright and right-angled

Requirements concerning the reproductions

- NO other objects, accessories, person or animal
- NO technical drawings (axes & dimension)
- NO explanatory text or legends



Disclaimer

Parts of the design itself and/or matters for which protection is not sought or

- Description
and/or
- Broken lines
and/or
- Coloring

Disclaimer by broken lines and description



DM/082544 "Shoe"

"No protection is sought for the matter shown in dotted lines (disclaimer)"

Disclaimer by broken lines

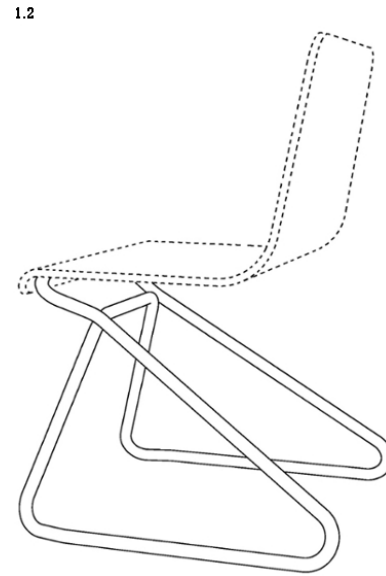
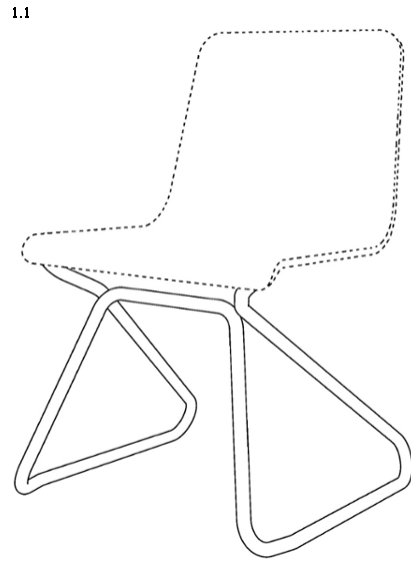

DM/090308 "Furniture leg"

Disclaimer by coloring and description

2.1



2.2



2.3



“The blue marked parts of designs 2 to 4 are not coming into the scope of the industrial design (disclaimer)”

DM/080861 “Vehicle bodywork”

Disclaimer by coloring and description

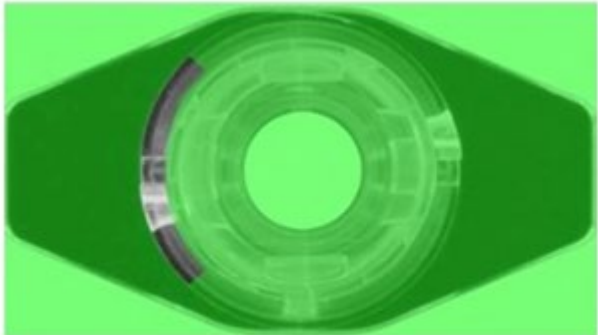
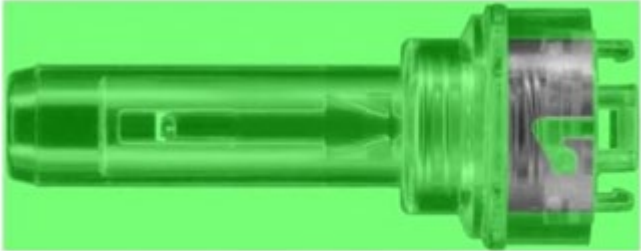

“The green colored parts form no part of the claimed design (disclaimer)”



Disclaimer by coloring

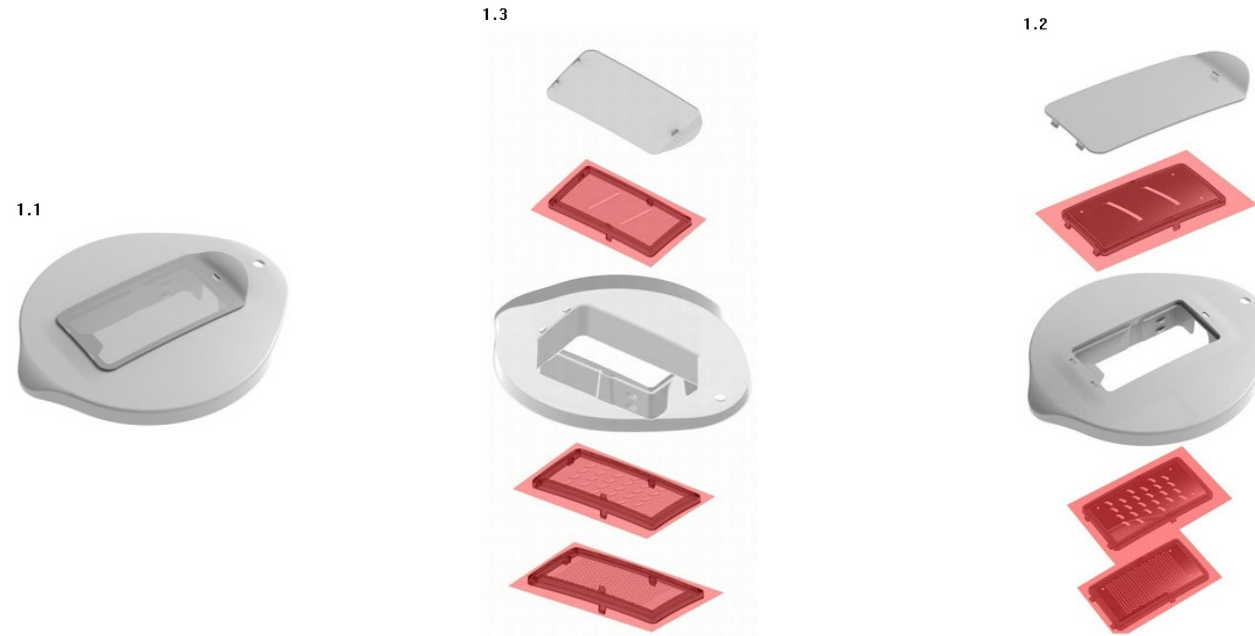

DM/080877 “Lid [household]”



Disclaimer by coloring

4.1



4.2



5.1



5.2



DM/205654

Disclaimer of the accessories and parts

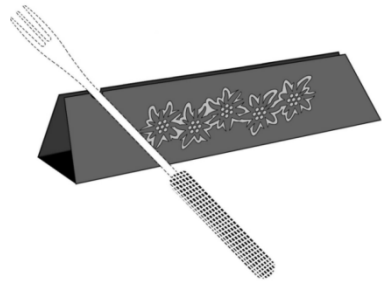

DM/080221 “Cutlery holder”



DM/207972



Disclaimer of the accessories and parts

Reproductions 4.1 - 4.8	Reproductions 4.9 - 4.16
"Skinny phone"	"Fat phone"
	



DM/207972



Examination practice

Photographs and/or other graphic representations
In black and white and/or color

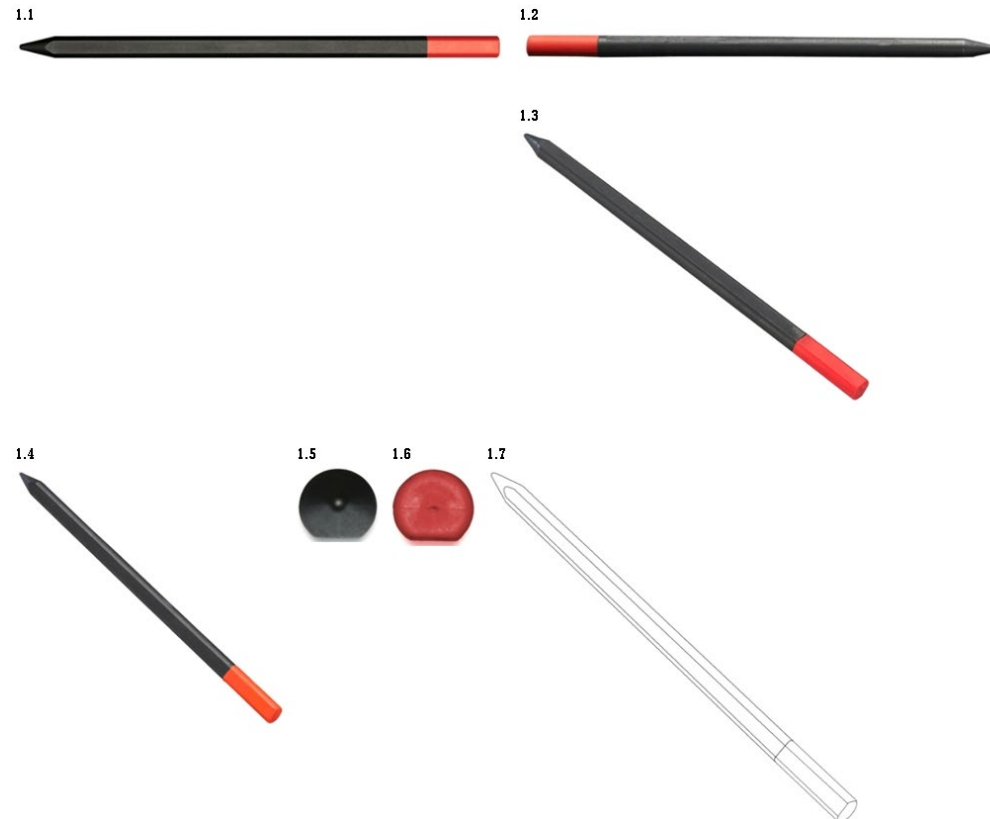

DM/090577 “Pencil”

Examination practice

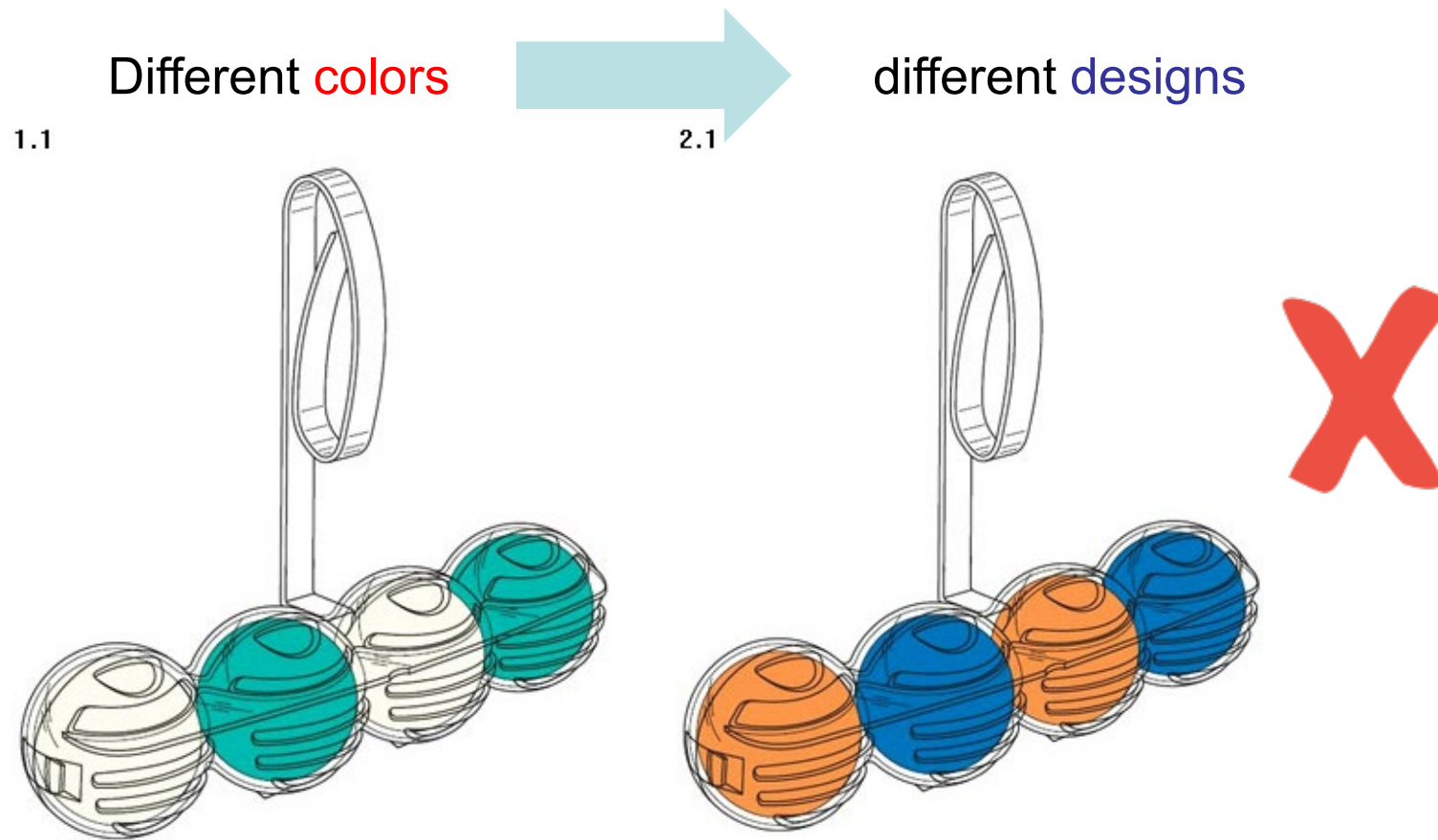

DM/078588 “Lavatory cleansing blocks”

Examination practice

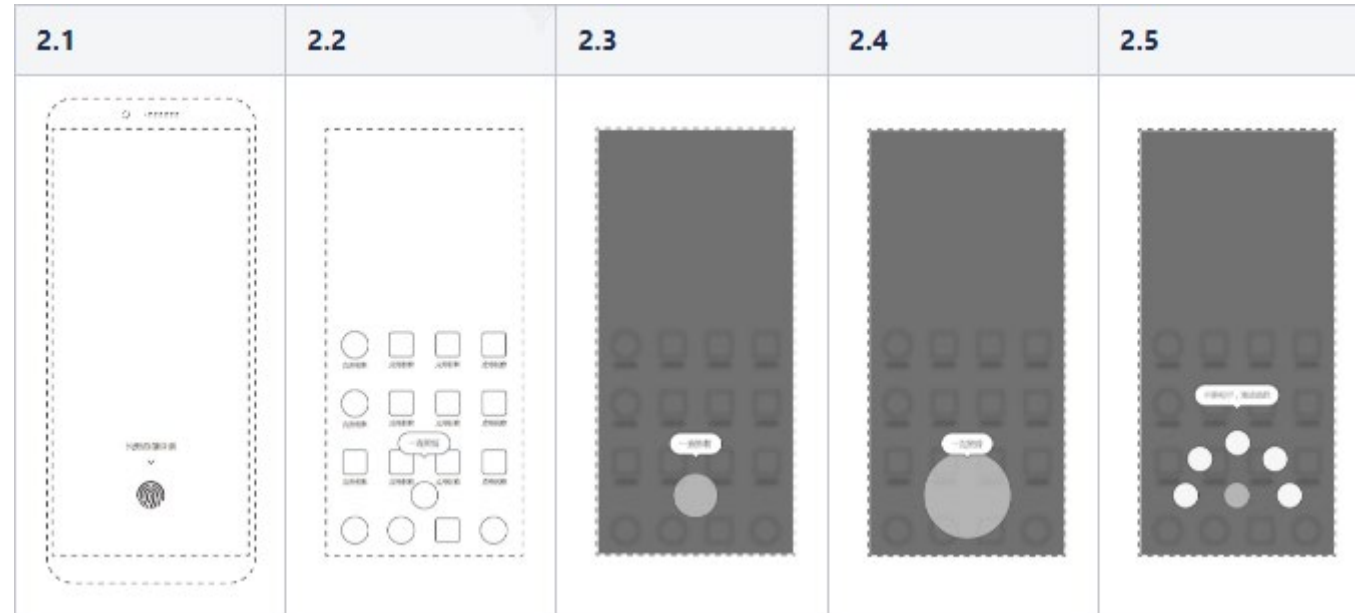

Animated graphical user interface for a display screen or portion thereof

DM/204978



Examination practice

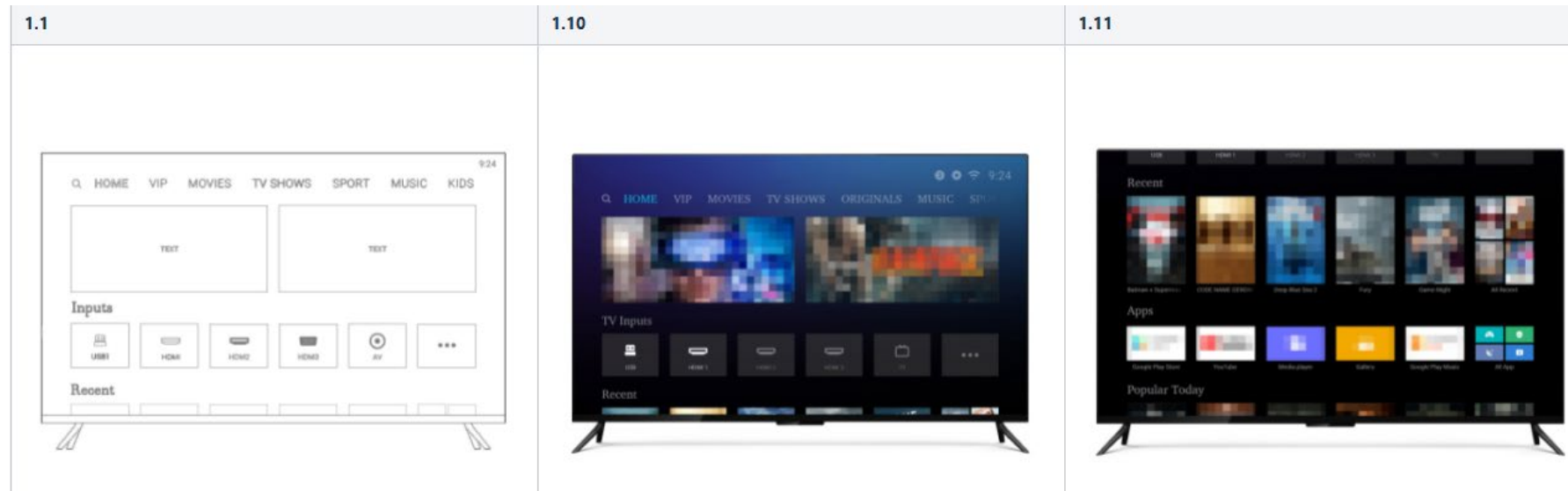

Transitional graphical user interface for television

DM/201 969



Examination practice

1.1



Containers with food products

DM/097 264

Examination practice

Cross-section view

Description: fig. 1.10 is a cross-sectional view taken along the A-A line shown in the fig. 1.6

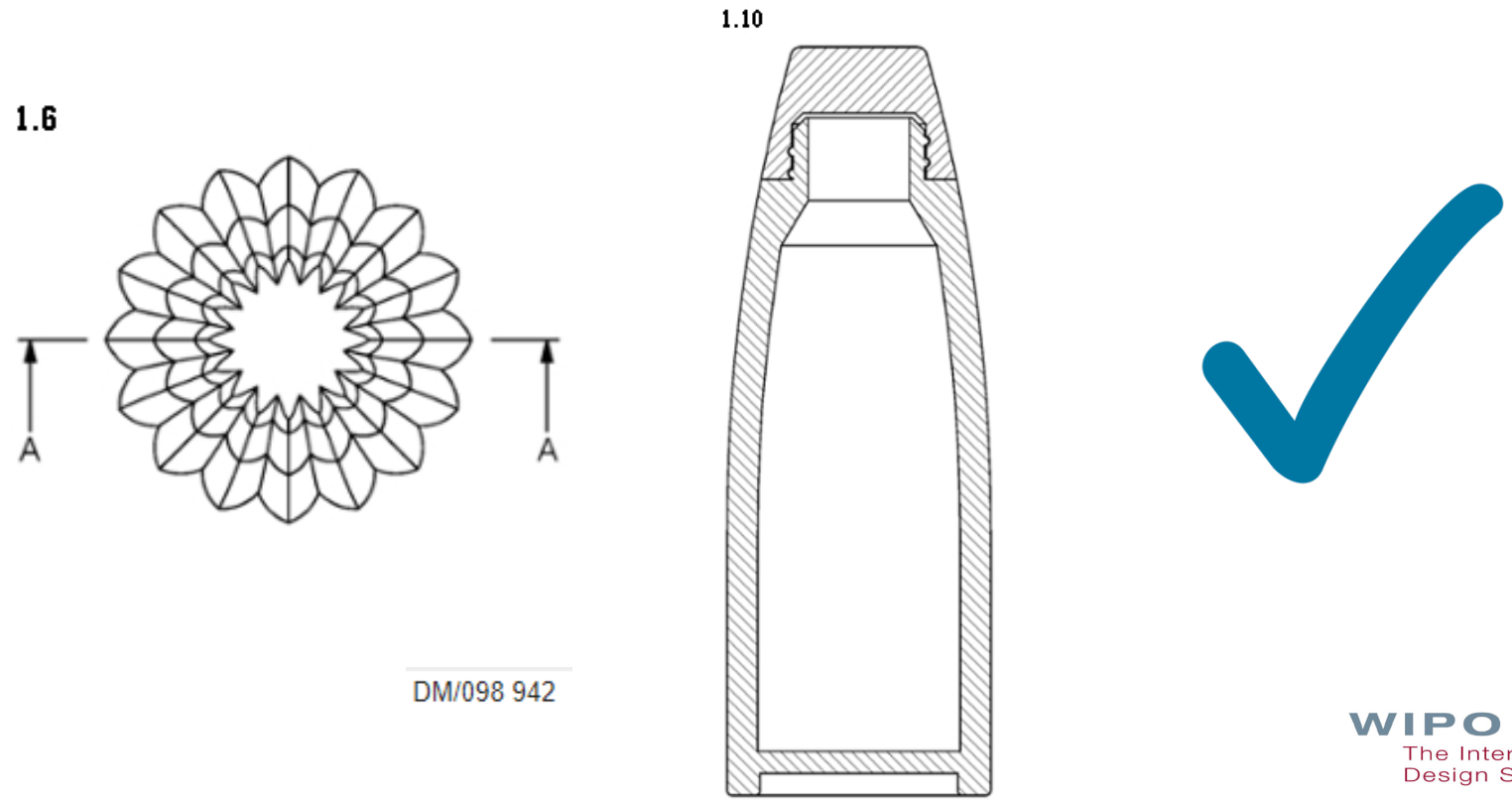

DM/098 942

Examination practice

Enlarged view

Description: The broken line box with a curvy line and the number 1.8, shown in view 1.1, indicate an enlarged portion of the design.

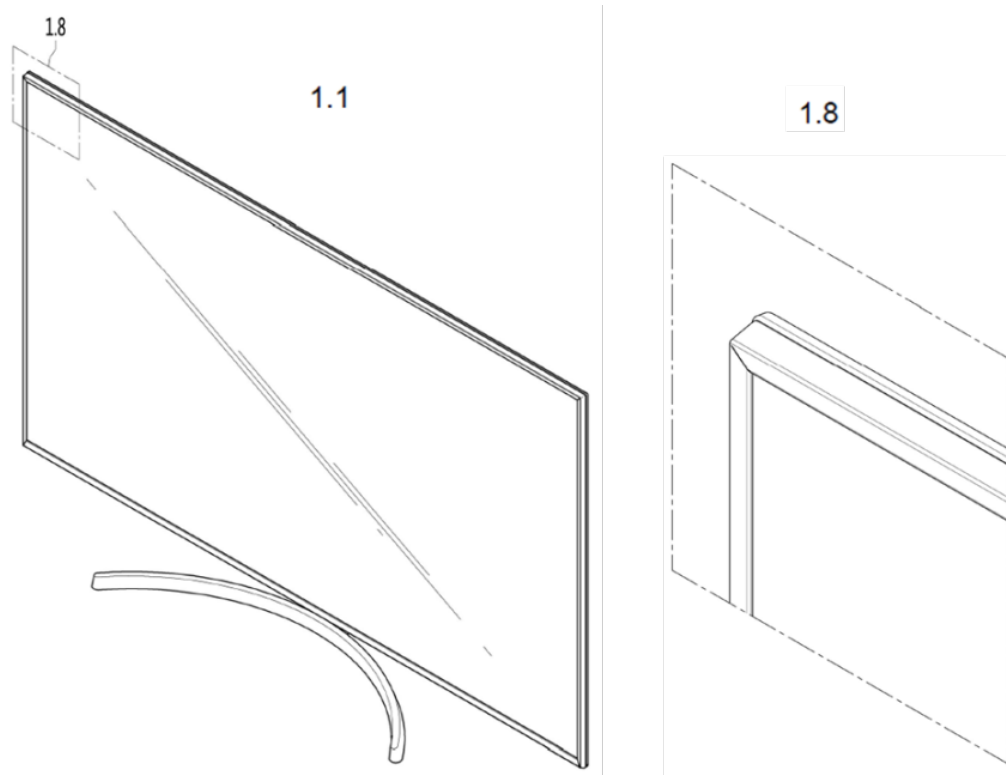

Examination practice

Technical drawings

Administrative Instruction 402(c)(i) contains a prohibition on technical drawings particularly with axes and dimensions

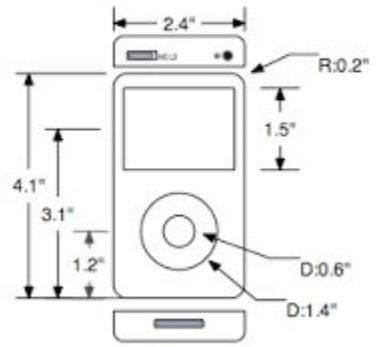
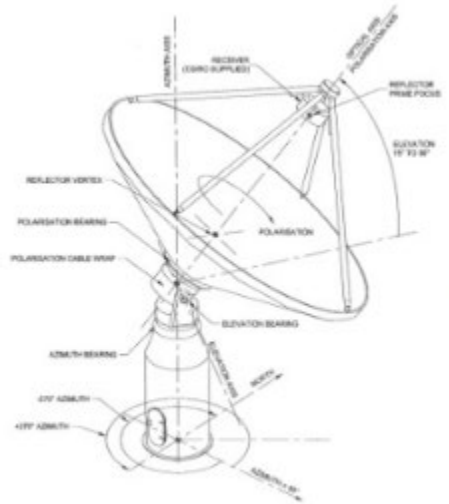
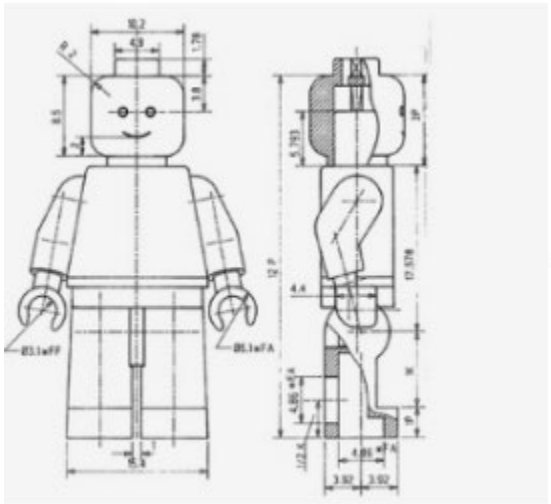

Examination practice

Exploded view

Description: Figs 2.1-2.7 are exploded views, the brackets forms not parts of the claimed design.

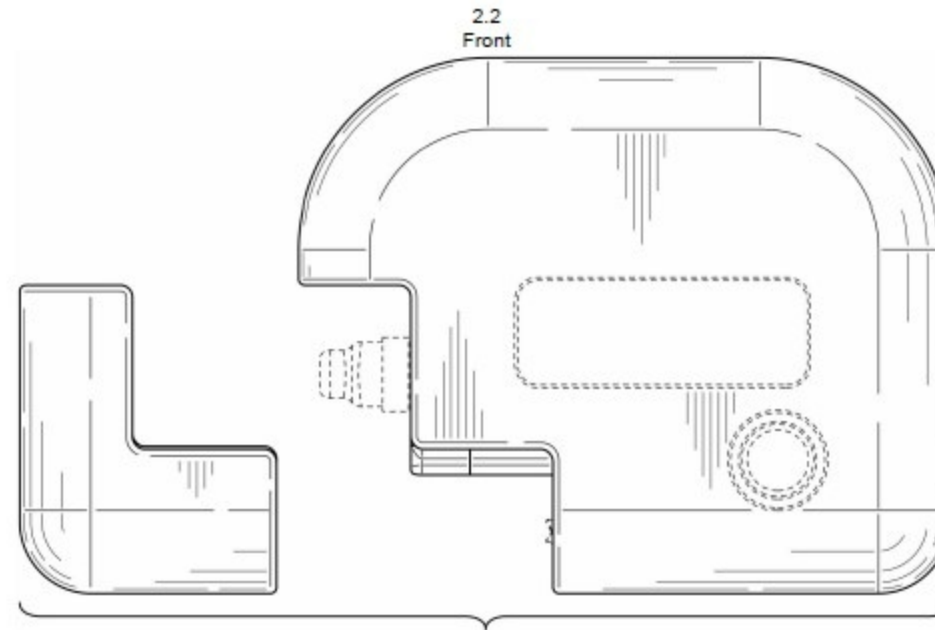

DM/210 011

Examination practice

Indeterminate length

Description: The jagged lines shown in the reproductions indicate the indeterminate length of the designs.

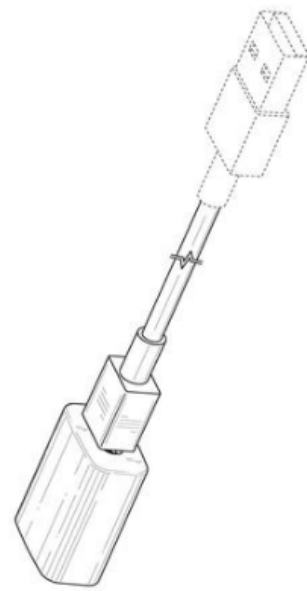
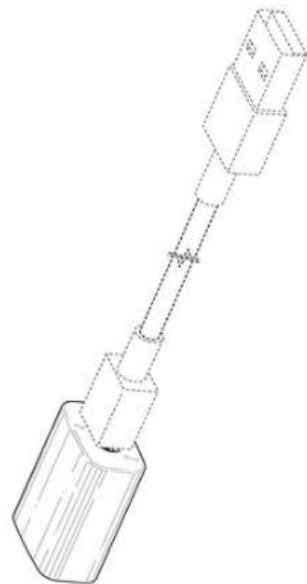

DM/210 011

DM/202755



Examination practice

Reproductions style

If an applicant chooses to mix reproduction styles within a single design, there is no requirement for a supporting statement in the description.



refused by UKIPO

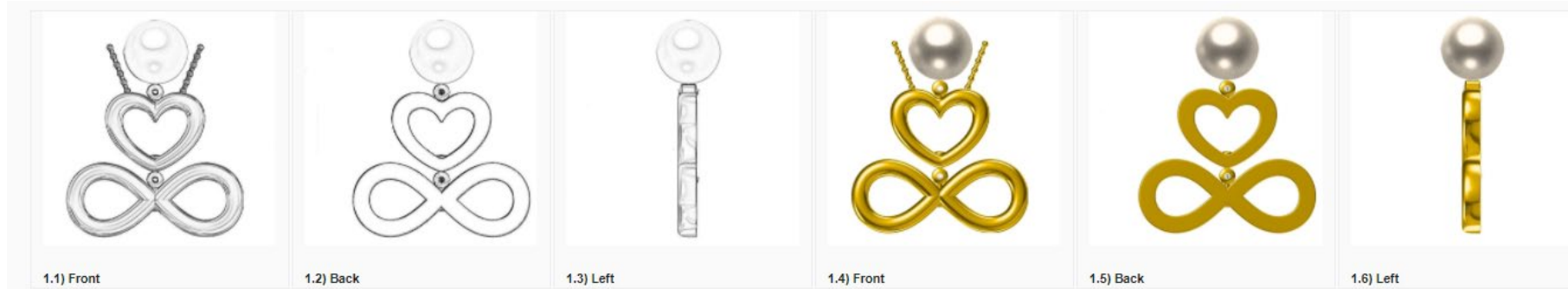

DM/214209

Examination practice

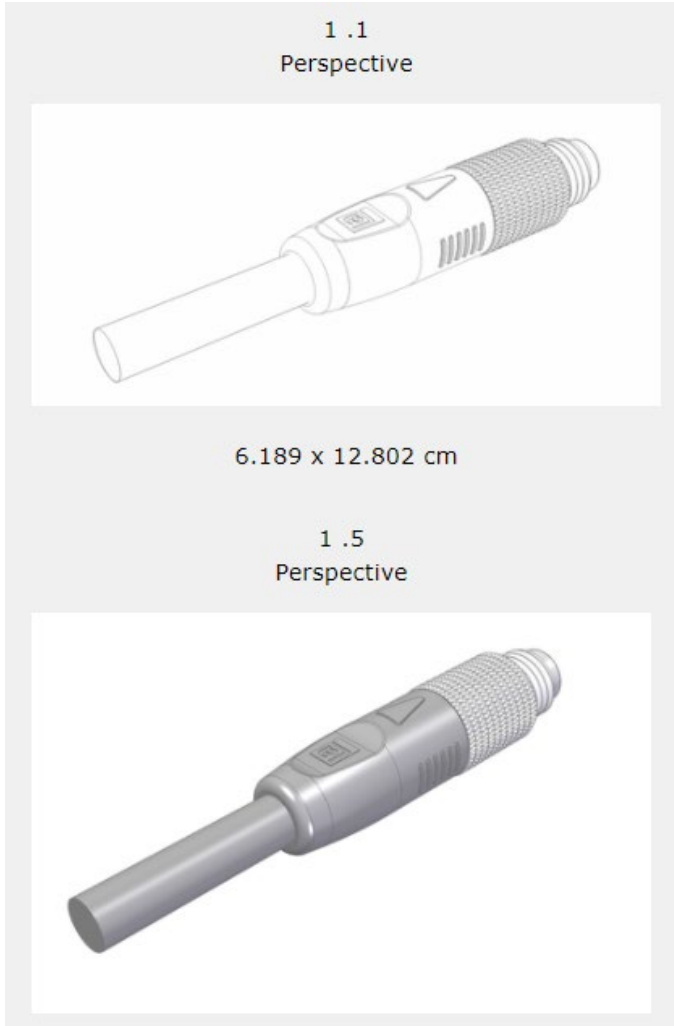

Reproductions style

Description: The gray shaded areas shown in reproductions 1.5-1.8 are included to show the areas of the design that are intended for colorization, which could not be shown in the line drawings of reproductions 1.1-1.4; the colorization of these areas forms part of the claimed design but no specific color is claimed



Examination practice

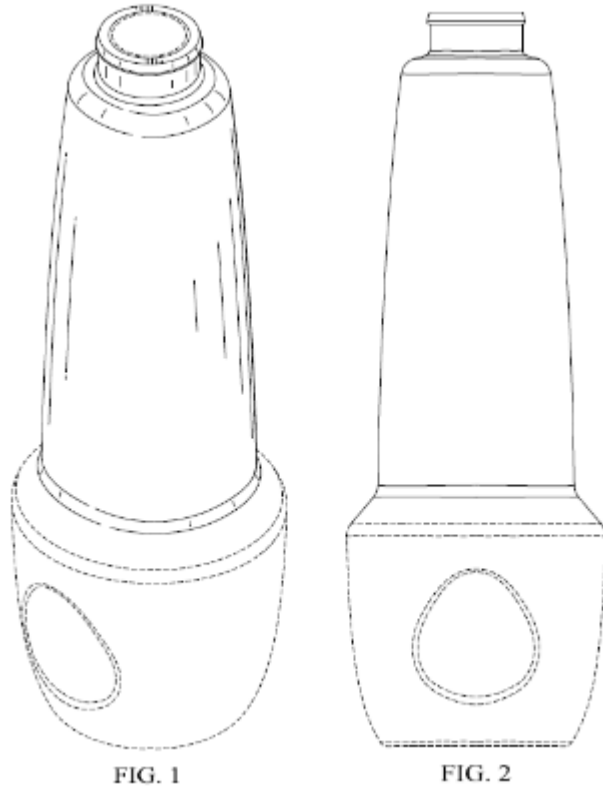

Reproductions style

Administrative Instruction 404(b) contains a statement”
The industrial design represented may comprise shading and hatching to provide relief.



Examination practice

Color shown in reproductions may be disclaimed

No protection is sought for the blue colored portions of the reproductions [disclaimer]; no protection is claimed for the color of the designs

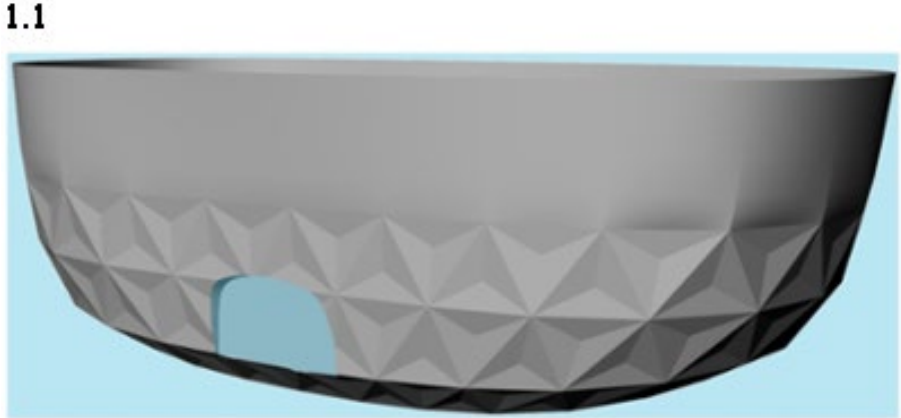

DM/099926





Examination practice

The color gradation can vary depending on the composition of the alloy...

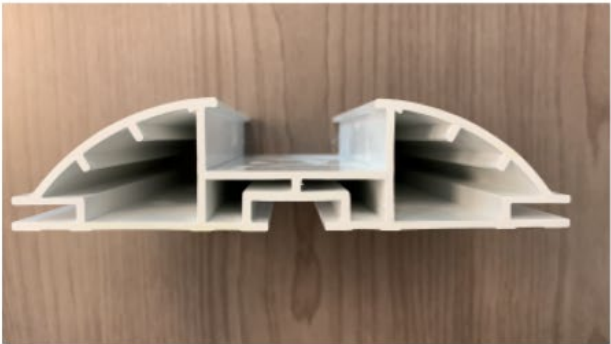
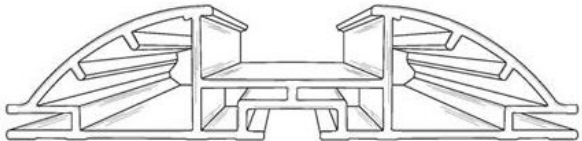

Examination practice

New reproductions

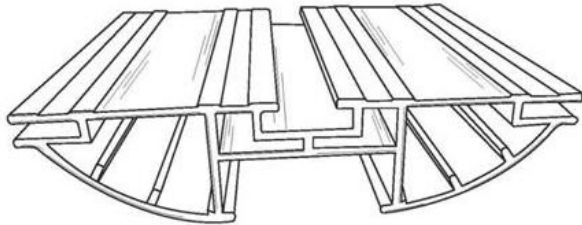
No	Original repros	Amended repros
1.1		
1.2		



Examination practice

Reference views require a textual or graphical disclaimer

Reproduction 1.7 is a reference photo showing an example of the usage of the subject design and forms no part of the claimed design

1.7



DM/098930



Examination practice

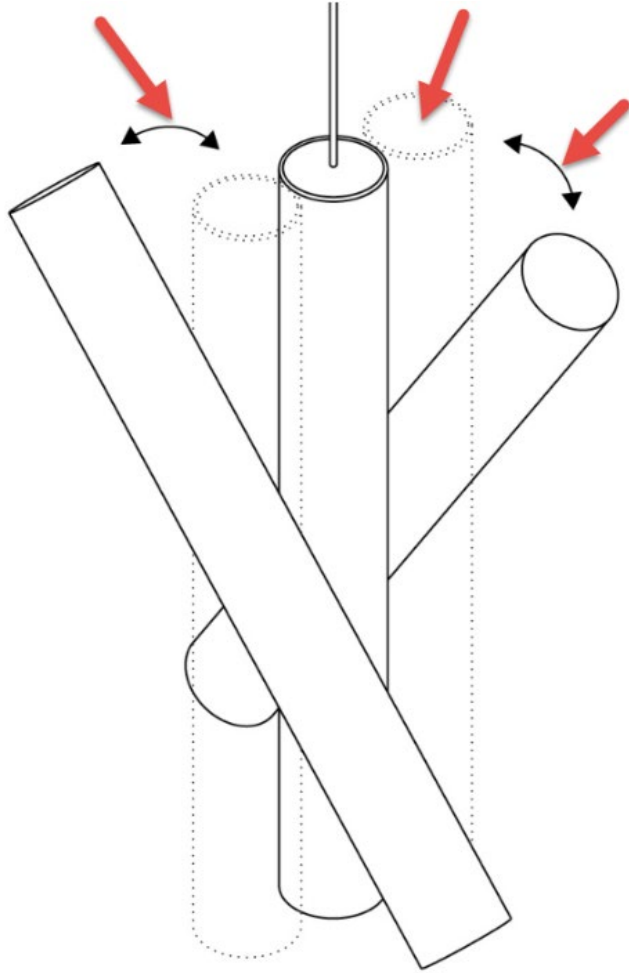

Alternative positions

A design containing multiple views or positions presented in a single reproduction is to be rejected





Examination practice

Visually correspond

The views as filed cannot be considered as one design as they do not visually correspond.



2.1 Logos	2.2 Logos	2.3 Logos	2.4 Logos
Groundfloor 	<u>Groundfloor</u> 	Groundfloor24 	Groundfloor24
2.5 Logos	2.6 Logos	2.7 Logos	
Groundfloor360	Groundfloor360° 	Groundfloor360°	

Examination practice

Radial lines

Views 1.1 to 1.4 illustrate the clay pigeon in an unilluminated state and views 1.5 to 1.7 illustrate the clay pigeon in an illuminated state.

Features shown in even broken lines do not form part of the claimed design, and are shown for context only. The radial lines around the boundary of the clay pigeon in views 1.5 to 1.7 illustrate emission of light from the surface of the clay pigeon.

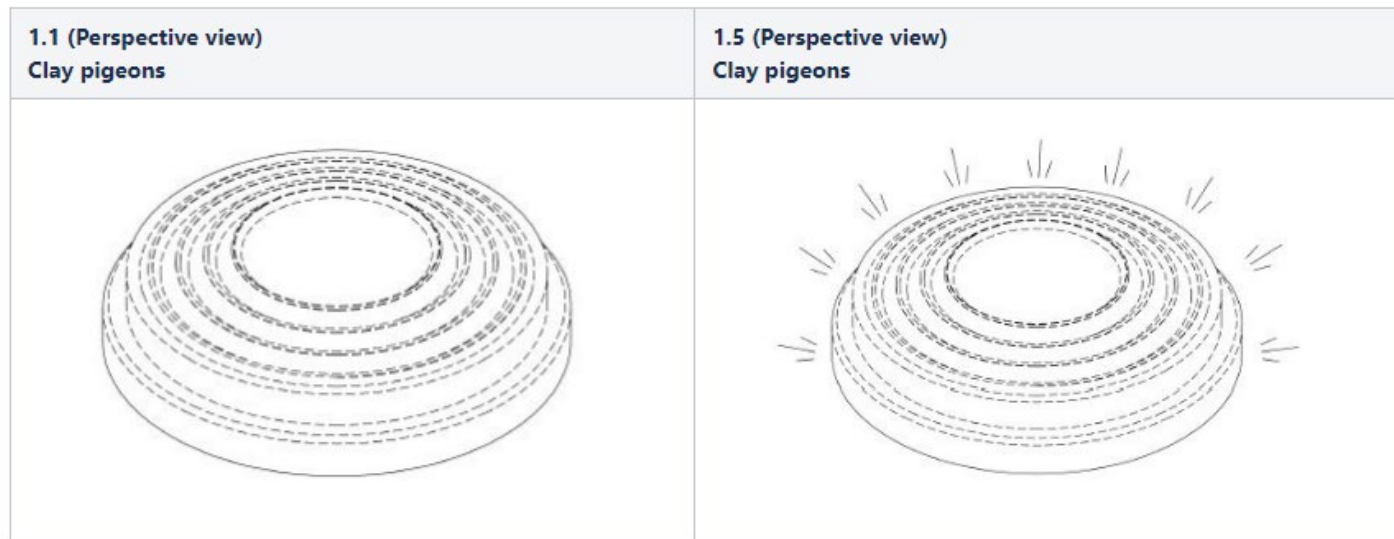

Examination practice

Neutral plain background



The following is not acceptable because (1) the background is not a neutral consistent background and (2) the background color bleeds into the design in some areas which makes it difficult to distinguish the background from the design. The background should be a consistent neutral or a consistent color and described and be easily distinguishable from the design.



Examination practice

Neutral plain background



The following is acceptable even though the background is not white, black, or gray. The blue background clearly shows the necessary details of the design.



Examination practice

Quality of reproductions

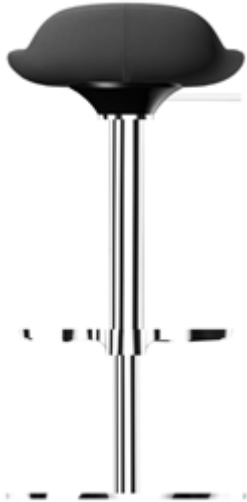

Metal portion showing reflections



Description

- Appearance of design
- Possible utilization
- View omitted
- Disclaimer
- Legends

Description - Legends

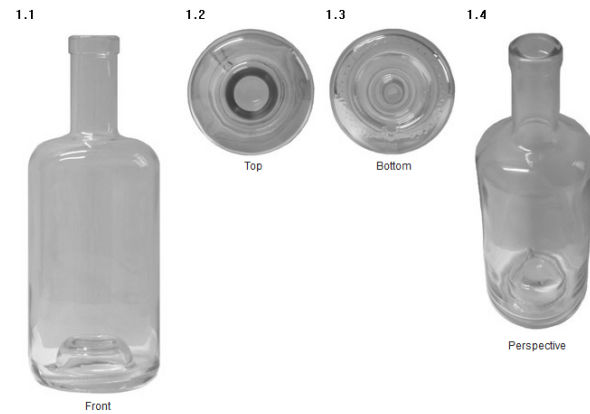

DM/085709; “Bottle”

Description

Design 1: 1.1 front view; 1.2 top view;
1.3 bottom view; 1.4 perspective view

Description - Views omitted



DM/084264; “Watch dial”

POSSIBLE description:

“Right side, top and bottom views are omitted because they are identical or mirror image of the left side view”

Description - Disclaimer

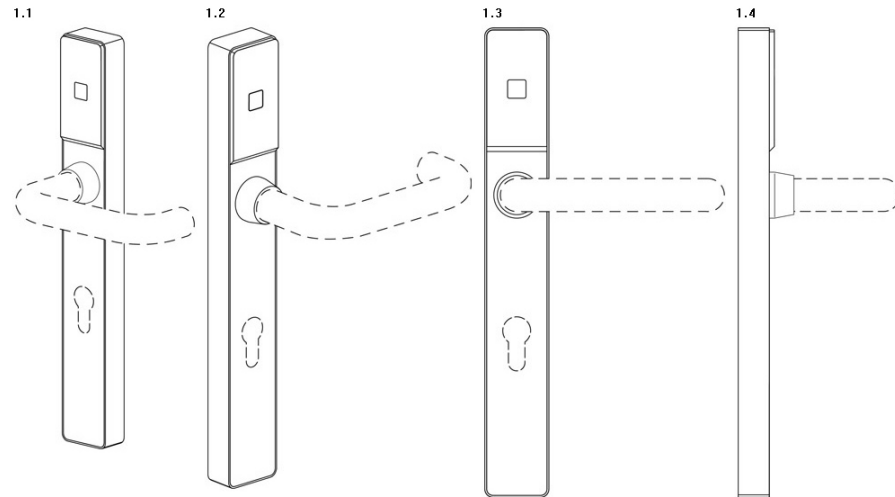

Description:

Design 1: the handle and the key hole, shown in broken lines, are not part of the claimed design;

DM/084412; “Door fittings”

Description - Visible features only



Description:

Bell characterized by a vertically-oriented rectangular front panel; the panel comprises an inscription in its upper part; underneath it there is a vertically elongated recess, whose edges are straight and rounded at the top and bottom

DM/085822; "Signal bell"

Product indication

- ❑ Specific and usually generic name

Lightening device



Table lamp

Communication equipment

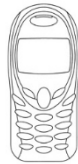

Mobile phone

- ❑ One per design

Carpets, mats or rug



Bathroom mat

Ornamentation, graphic symbol or logo



Logo

Product indication

- ❑ Can be a part of the product or product itself



DM/082544 “Shoe”



“Shoe heel”

Product indication and Locarno classification

- ❑ Industrial designs are classified in accordance with the product indication

Class 32-00

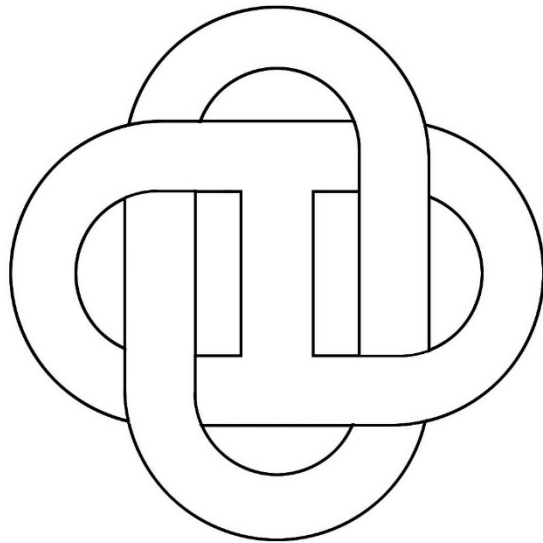

DM/081718; “Ornamentation”

Class 09-05



DM/084887; “Ornamentation for packaging bags”

Locarno classification - Mono class

Class 6



DM/083137

Locarno classification: Multiple classes



Irregularities

- 3 months - filing date is affected
- 3 months - registration date is affected
- 3 months - date is not affected
- 1 month observation with possibility to response
- Observation for information



International application: irregularity notice

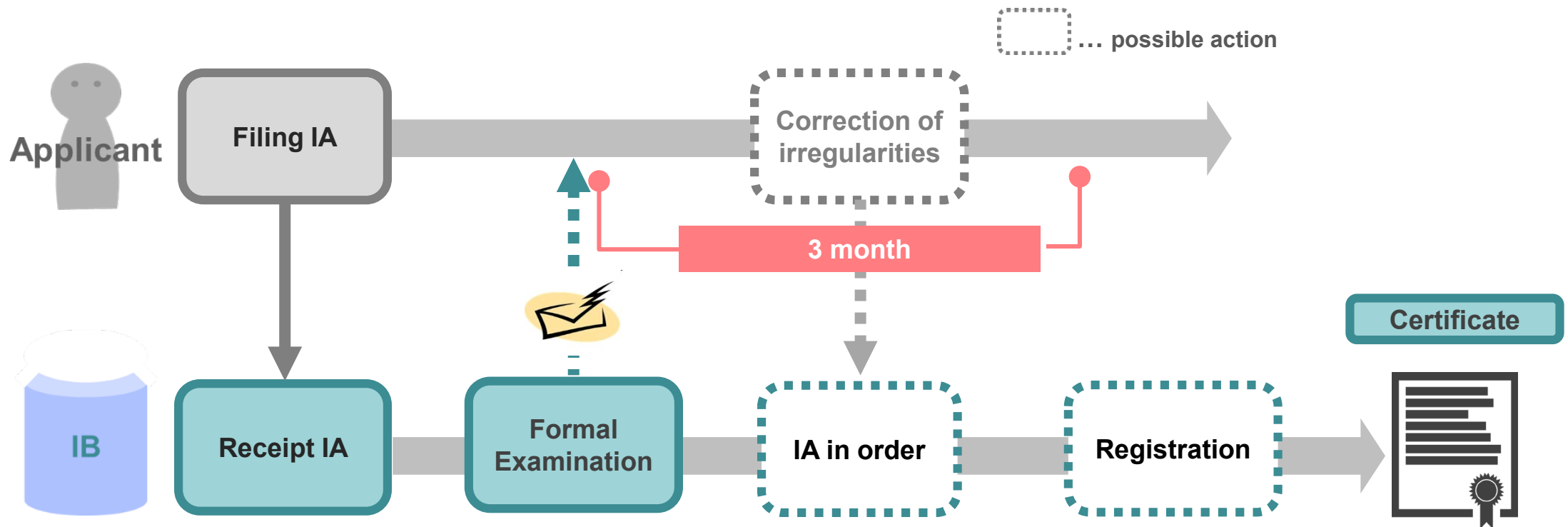

Publication and its Deferment

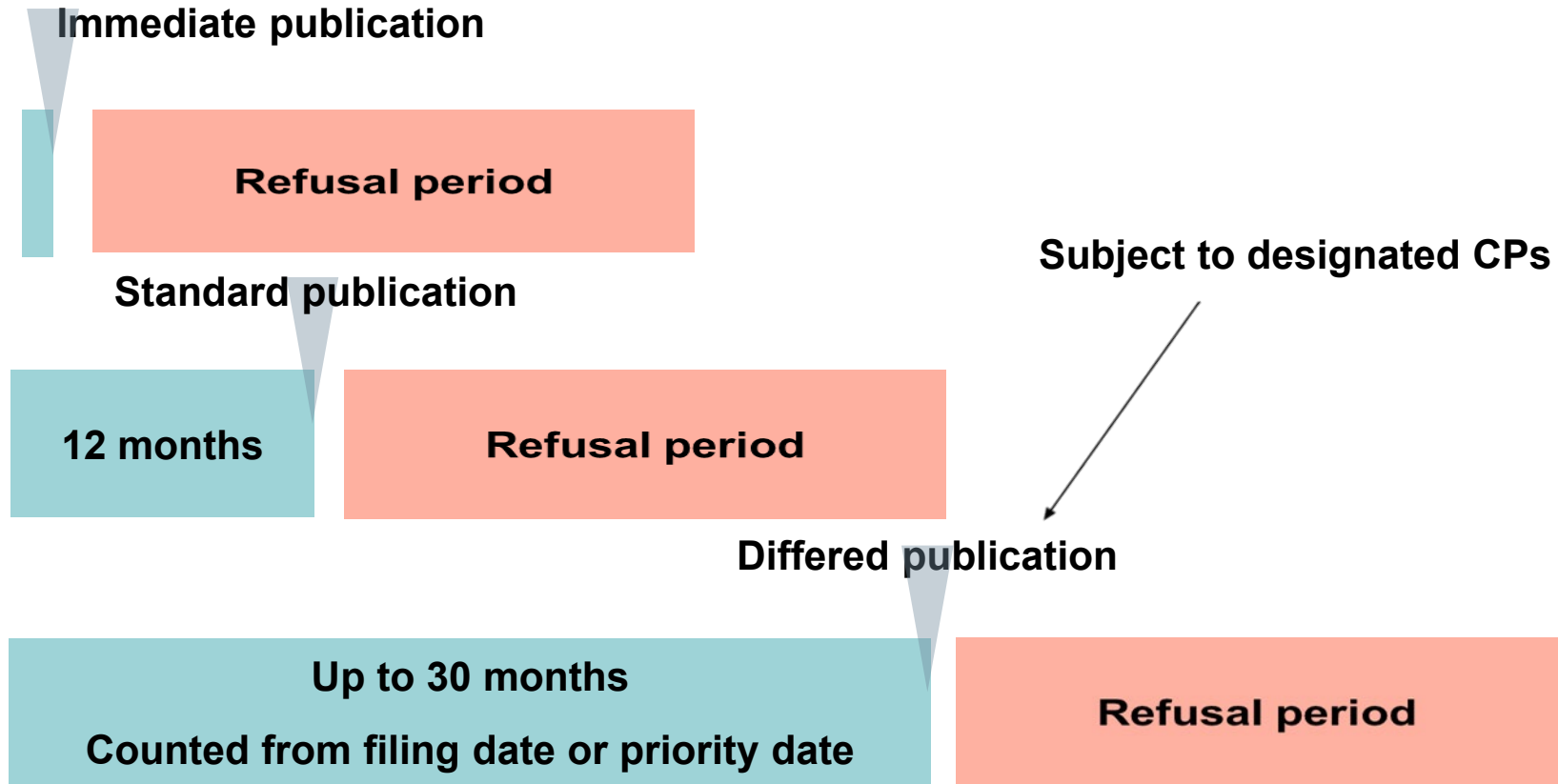

Effects of an IR under the 1999 Act

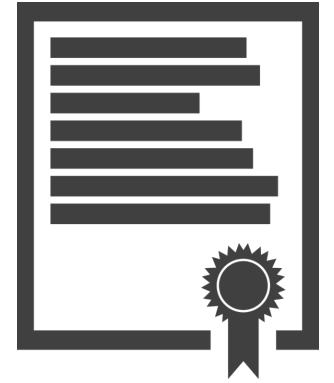

- After publication (Article 14(1))
= effects *as application* from the date of IR, *at least*
- If no refusal is notified (Article 14(2)(a))
= effects *as a grant of protection*, in principle, *at the latest from the expiry date of the applicable refusal period (6 or 12 months)*
- If the refusal is withdrawn (Article 14(2)(b))
= effects *as a grant of protection at the latest from the date on which the refusal was withdrawn*

Refusal and other Office Actions

- Refusal
- Withdrawal of Refusal
- Statement of Grant of Protection
- Invalidation



Refusal: Basic Principles



- **Within refusal period:** starting from the date of international publication (6 to 12 months)
- **Provisional objection:** which may become a **final decision**, without further notification
- Languages: English, French or Spanish
- Total (for all the designs) or partial (for some of the designs only)

Refusal Ground: no formal ground

- Principle:
substantive grounds only (incl. opposition)
 - Exceptions:
 - requirement as to unity of design (Article 13) *
 - specific views of the design not furnished
(Rule 9(3)(a)) *
- * Declarations possible only under the 1999 Act



Refusal Ground: typical substantive grounds



- Definition of an industrial design
 - Type of design not protected (ex. “logo”)
 - Disclosure insufficient to figure out the design

- Public order and morality
- Conflict with prior applications / registrations
- Novelty

Refusal Mechanism

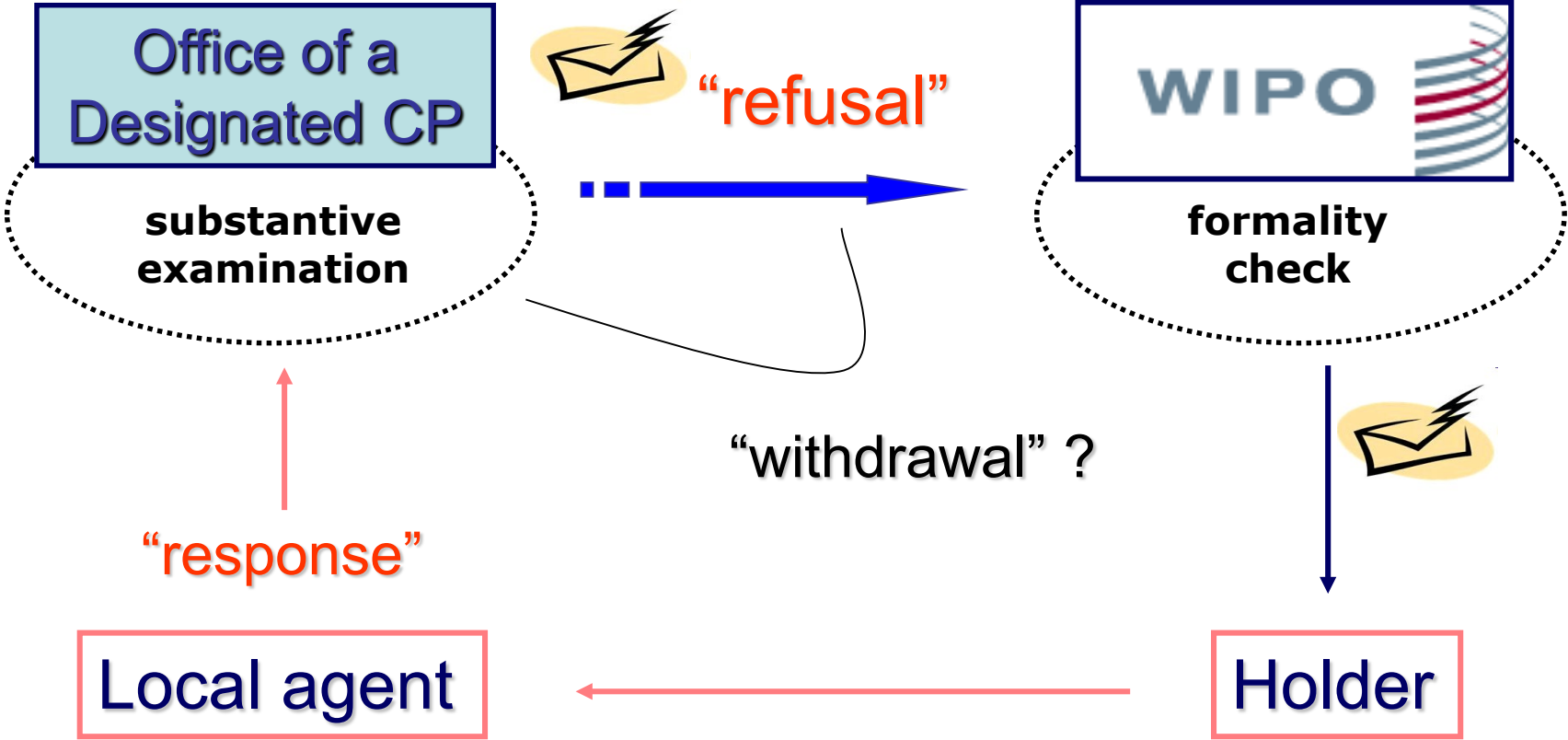

Withdrawal of Refusal / SGP

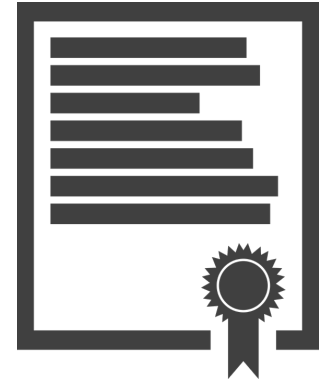

- After refusal
 - Notification of withdrawal of refusal (Rule 18(4))
 - Statement of grant of protection (Rule 18bis (2))

- Where no refusal
 - Statement of grant of protection (Rule 18bis (1))
 - *within the applicable refusal period*
 - *optional but recommended*

Invalidation



- **Office or court decision** which is made after producing protection (Rule 20)

- **Remarks:**
 - Outside the “Refusal” mechanism
 - “Post-grant opposition” included
 - Opportunity to defend the right
 - Only the **final decision**

Post-Registration Procedures

- Change in name and/or address of the holder
- Appointment, change or cancellation of representative
- Change in ownership
- Renunciation (in respect of some or all designated CPs)
- Limitation (in respect of some of the designs)
- Renewal



Advantage Summary



<u>Hague System</u> <u>(International Route)</u>	<u>National/Regional</u> <u>Route</u>
<p><u>One</u> Office for filing <u>One</u> language <u>One</u> currency <u>One</u> international registration <u>One</u> renewal <u>One</u> modification Foreign attorney or agent (<u>first needed if refused</u>)</p>	<p><u>Many</u> Offices for filing <u>Many</u> languages <u>Many</u> currencies <u>Many</u> registrations <u>Many</u> renewals <u>Many</u> modifications Foreign attorney or agent (<u>first needed at filing</u>)</p>

Renewal

■ Duration of Protection

- Initial term: five years

- Minimum duration

 - 1960 Act: 10 years (5 + 5)

 - 1999 Act: 15 years (5 + 5 + 5)

- maximum duration in each CPs:
(*check: [CP declarations](#)*)



Renewal

■ Possible

- Maximum period expired
- Refusal recorded



■ Not Possible

- Renunciation recorded
- Limitation recorded
- Invalidation recorded

