



IP and Sport
from the WIPO
Perspective

May 28 and 29, Ljubljana

**Virag Halgand, Head
Section for Central European and
Baltic States and Mediterranean Countries, TDC,
WIPO**

APRIL 26
REACH
FOR GOLD
IP AND SPORTS
WORLD INTELLECTUAL PROPERTY DAY
2019

 [#worldipday](https://twitter.com/worldipday)
wipo.int/ipday
[youtube.com/wipo](https://www.youtube.com/wipo)



- International Intergovernmental Organization
- Since 1967
- 192 Member States
- 350 + accredited observers
- 1300 staff from 120 countries
- 26 administered treaties



Jamaica Offers Signed Photo of Ussain Bolt to WIPO
(Photo: WIPO)

What we do



Frustrated by being unable to ski with his children after losing his legs, **Jim Morrison** invented the mono-ski, allowing athletes like Chris Devlin-Young, shown here at the X Games, to compete. (© AP Images)

We help governments, businesses and individuals make **intellectual property** work for **innovation** and **creativity**



Soccer, as the most popular sport in the world, has enormous potential to promote sustainable social and economic development. Here children playing soccer on the street in village center of Capurgana, Colombia. (Photo: hanohikir / Alamy Stock Photo)

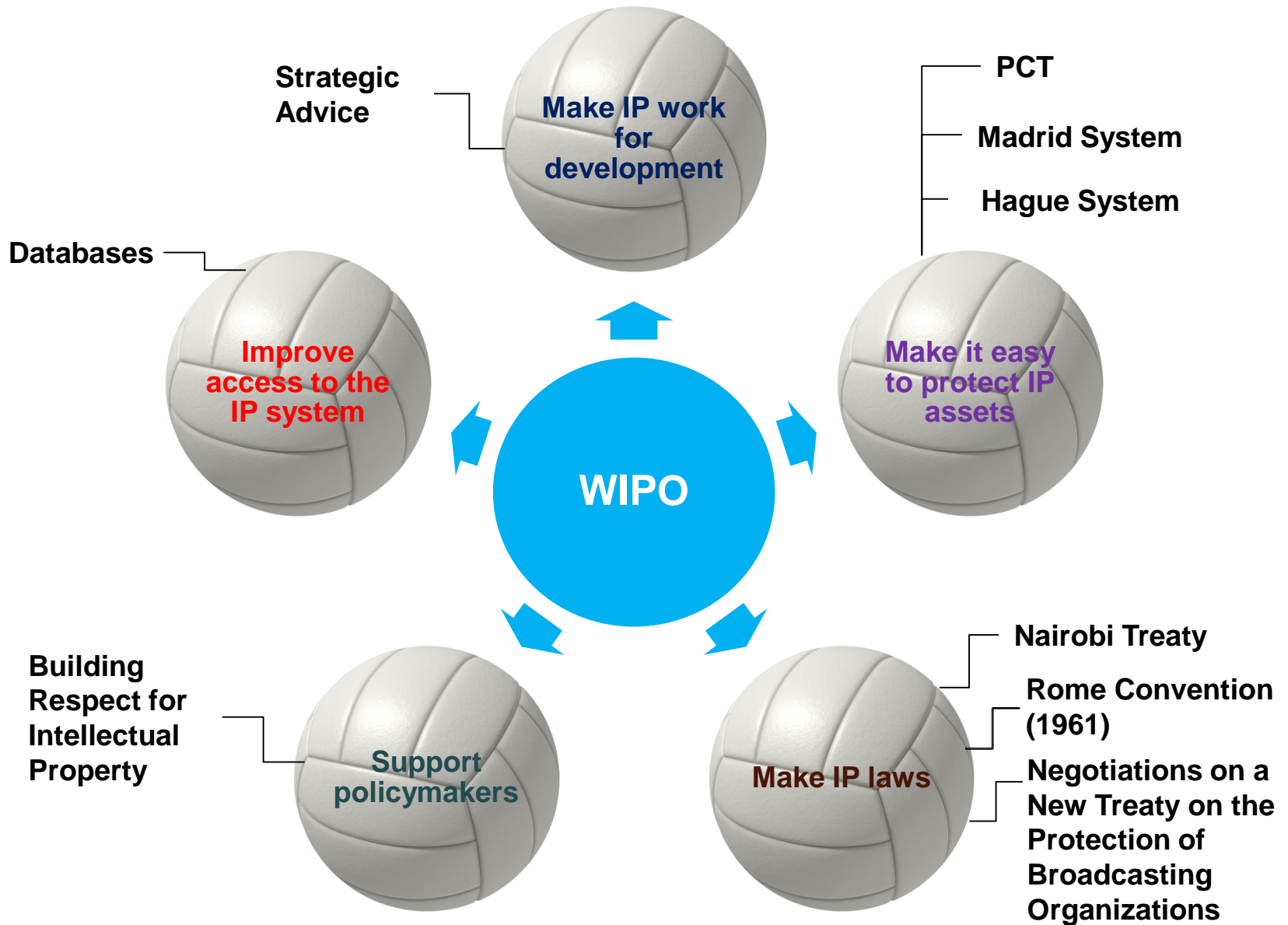

WIPO Services

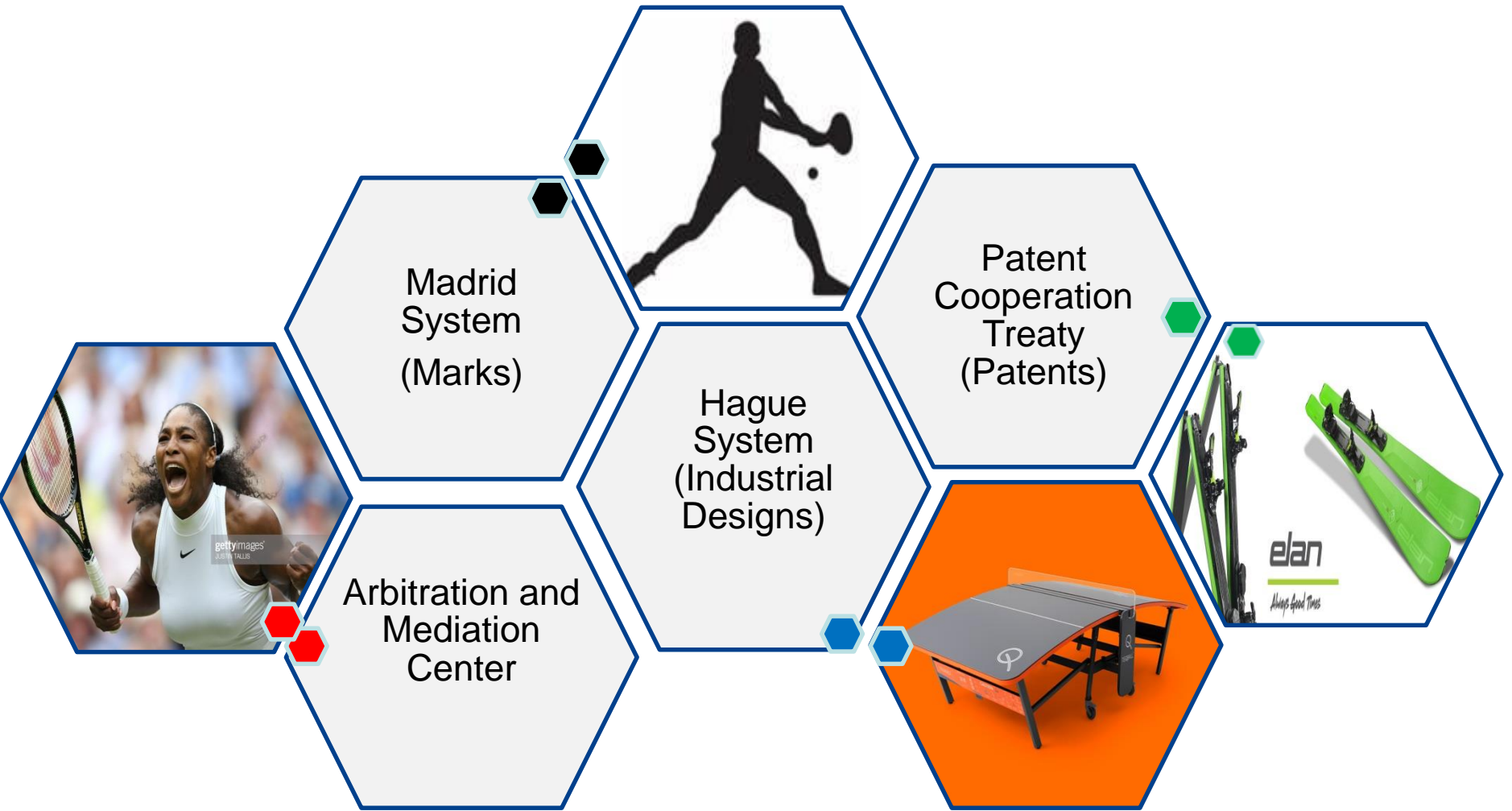

Global IP Systems: Rationale and Commonalities

- To facilitate the acquisition of rights in multiple jurisdictions
- Special Agreements under Art. 19 of the Paris Convention
 - Closed» Systems
 - Slovenia and almost all countries in the Region are party to all!
- Procedural Treaties
- Madrid and Hague Systems «Registration» Systems
 - Access a centralized filing and management procedure
 - File one application, in one language and pay one set of fees for protection in multiple export markets
- PCT System provides a worldwide system for simplified filing and processing of patent applications
 - postpones the major costs associated with internationalizing a patent application
 - provides a strong basis for patenting decisions
 - harmonizes formal requirements

Patent Cooperation Treaty (1970)

- 152 contracting parties
 - Latest accession: Jordan (2017), Cambodia (2016)
 - 253 000 applications in 2018 → **3.9% growth in 2018**
- 3,5 million applications in total

Madrid System (1891 and 1989)

- 104 contracting parties (covers 120 countries)
 - Latest accession: Canada (March 2019)
 - 61 200 applications in 2018 → **6.4% growth in 2018**
- Since its inception in the late 19th Century, over 1 million (1,034721) trademarks have been registered under the Madrid System
- First sport trademark registration- Luxottica in 1947 registered a trademark for its sports glasses

Hague System (1924)

- 70 contracting parties
 - Latest accessions: Canada, United Kingdom, San Marino, the Russian Federation
 - 5,404 applications containing 19, 296 designs → **3.7% growth in 2018**
- 34 700 international registrations in force in 2017 containing around 140 000 designs

Snapshot view of global patenting activity

In total, 2,078 sports-related applications[*] under PCT were published by WIPO in 2018, a 9% increase on figures for 2017 (1,900 PCT applications) and a 41% increase on figures for 2014 (1,470 PCT applications).

TOP PCT SPORT-RELATED APPLICANTS (2014-2018)*

Applicant	Sport-related PCT applications (published 2014-2018)
NIKE	239
KARSTEN MANUFACTURING CORPORATION	77
3M INNOVATIVE PROPERTIES COMPANY	44
SONY CORPORATION	43
ICON HEALTH & FITNESS, INC.	43
ENPLAS CORPORATION	37
DECATHLON	28
GOLFZON CO., LTD	27
SHENZHEN ESMARTGYM SCIENCE AND TECHNOLOGY CO., LTD	25
PARSONS XTREME GOLF, LLC	25

* Sports-related patent applications are those bearing relevant International Patent Classification (IPC) codes. These codes are used to classify patents and utility models according to the areas of technology to which they relate. WIPO selected several dozen IPC codes that related closely to sports. PCT applications represent a portion of worldwide patenting activity

Global Databases and tools

- PATENTSCOPE

- WIPO Translate

- Global Brand Database

- State-of-the-Art Artificial Intelligence-Based Image Search Tool

- Global Design Database

- WIPO Lex

- WIPO Pearl

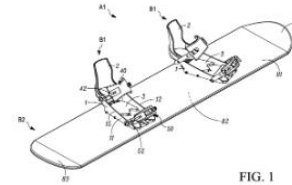
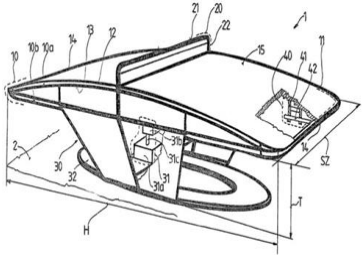
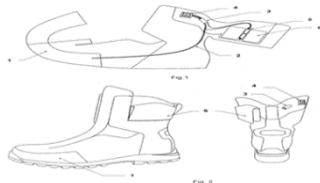
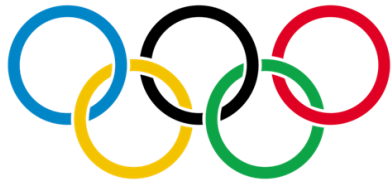

FIG. 1



WIPO FOR OFFICIAL USE ONLY



PARIS 2024



WIPO
WORLD
INTELLECTUAL PROPERTY
ORGANIZATION

Use of PCT – Some examples

TEQBALL Table

- Utility Model
- PCT application filed in Hungary in 2013 (PCT/HU2013/000107, “Multi-purpose Sports Apparatus”).

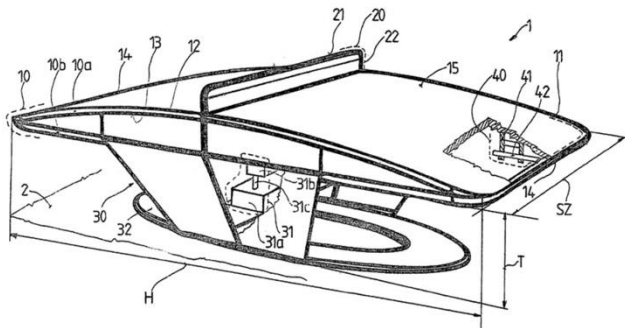

ELAN – Folding Ski

- Patent
- PCT application filed in Slovenia in 2018 (PCT/IB2018/057350, “Folding Ski”).

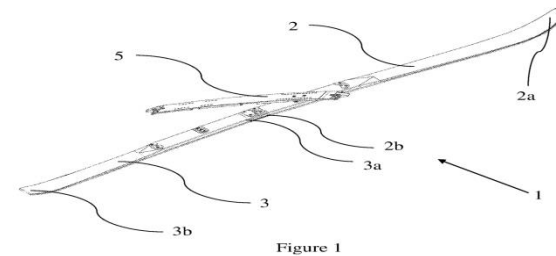

Patenting and New Technologies

A focus on Esports



Top ten sports by growth

Potential to grow revenues globally

1	Esports		6	Rugby	
2	Football/ soccer		7	American football	
3	Basketball		8	Cycling	
4	Mass participation sports		9	Tennis	
5	Boxing/ martial arts		10	Cricket	

Use of PCT - Esports



- Skillz is a Worldwide Leader in mobile eSports
 - Connects the world's 2.6 billion mobile gamers through competition
 - 18 million gamers use Skillz to compete in mobile games across 13,000+ game studios

➤ 8 International applications

- SONY has developed a system that allows VR headset wearers to remotely spectate a live esports tournament.

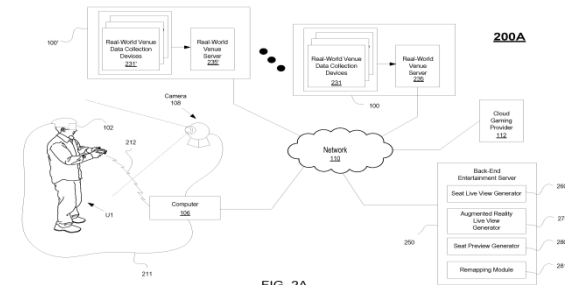

➤ International application filed on August 22, 2018.

Use of the Madrid System – Some Examples

Novak Djokovic – Personal brand and trademarks

Lacoste - range of Djokovic-branded clothing, apparel and other merchandise for general sale to fans.



- Many athletes and sporting organization are leveraging their personal brands (built around their sporting success) to generate significant revenue through endorsement contracts with major sportswear and other companies.



novak

Fédération Internationale de Football Association (FIFA)

Mark Name: Russia 2018

Mark Number: 1093235

Date of Registration: 01.06.2011

Nice Classification: Classes 01, 03, 04, 05, 06, 09,
10, 12, 14, 16, 18, 20, 21, 24, 25, 26, 28, 30, 32,
33, 34, 35, 36, 37, 38, 39, 41, 43.

Countries: AM, AU, AZ, BH, BW, BY, CU, DZ, EG,
GE, GH, HR, IL, IR, JP, KE, KG, KR, KZ, MA, MD,
ME, MK, MN, NO, NZ, OM, RS, RU, SG, SY, TJ,
TM, TR, UA, US, UZ, VN.

RUSSIA 2018

Comité International Olympique

Mark Name: Beijing 2022

Mark Number: 1445565

Date of Registration: 01.05.2018

Nice Classification: Classes 01, 02, 03, 04, 05, 06,
07, 08, 09, 10, 11, 12, 13, 14, 15, 16, 17, 18, 19,
20, 21, 22, 23, 24, 25, 26, 27, 28, 29, 30, 31, 32,
33, 34, 35, 36, 37, 38, 39, 40, 41, 42, 43, 44, 45.

Countries: AL, AM, AZ, BA, BT, BY, BW, CU, DZ,
EG, GE, ID, IL, IR, IS, JP, KE, KG, KP, KR, KZ,
LA, MA, MC, MD, ME, MK, MN, MX, NO, NZ, OA,
PH, SG, RS, RU, SM, TH, TJ, TR, UA, UZ, VN,
ZW.



Do you recognize?

ALPINA – Slovenian Footwear Manufacturer

ALPINA is a development-oriented footwear manufacturer

- International Trademark



- PCT Application (2016)

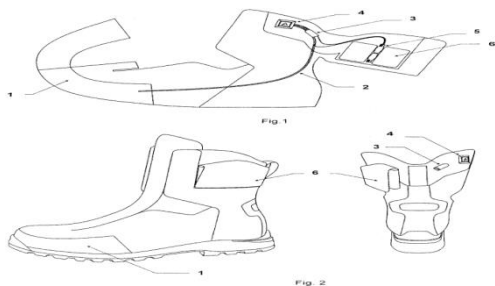

Use of the Hague System – Examples

TEQBALL Table

International Registration filed on July 12, 2015 for the following designs:

Design 1 is a table for playing teqball sport game; the table has a curved shape and is bicolor, grey and orange;

Design 2 is a table for playing teqball sport game; the table has a curved shape and is tricolor, grey, orange and yellow; design 2 is a folding table

1.4



2.1



2.6



ASICS Sports Shoes

International Registration filed on May 29, 2017 for the following design:





Normative Activity

[#worldipday](#)

© Petrus Wouter / Getty Images, © iStock / Getty Images, © iStock / Getty Images

The Nairobi Treaty and the Olympic Properties

All States party to the Nairobi Treaty are under the obligation to protect the Olympic symbol – five interlaced rings – against use for commercial purposes (in advertisements, on goods, as a mark, etc.) without the authorization of the International Olympic Committee.

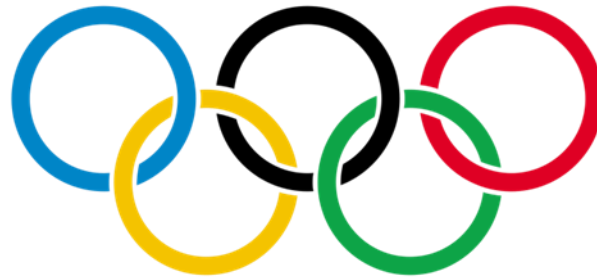

The Nairobi Treaty and the Olympic Properties

- 52 Contracting Parties

- Including 20 countries from the CEBS and CACEEC Region: Bosnia Herzegovina, Bulgaria, Croatia, Estonia, Hungary, Republic of North Macedonia, Montenegro, Poland, Republic of Moldova, Romania, Serbia, Slovenia, Azerbaijan, Belarus, Kazakhstan, Kyrgyzstan, Russian Federation, Tajikistan, Turkmenistan, Ukraine

- Latest accessions: Turkmenistan (2015), Republic of North Macedonia (2014), Bosnia Herzegovina (2012).

The Nairobi Treaty and the Olympic Properties

■ **Who** is missing on the list of CPs ?

Large sports events organizers (CN, US, CAN, UK)

■ **Why** ?

Protection is ensured through private or contract law.

National trademark laws already provide for protection of the Olympic Symbol.

■ **Still, why** do countries adhere?

A treaty obligation provides a ground for enacting protective national laws and regulations.

Rome Convention for the Protection of Performers, Producers of Phonograms and Broadcasting Organizations (BOs)

- Adopted in 1961, never revised
- 93 Contracting Parties
- Article 3 Definitions:
 - “broadcasting” means the transmission by wireless means for public reception of sounds or of images and sounds;
 - “rebroadcasting” means the simultaneous broadcasting by one broadcasting organisation of the broadcast of another broadcasting organisation.
- BO’s have the right to authorize or prohibit certain acts, namely the rebroadcasting of their broadcasts; the fixation of their broadcasts; the reproduction of such fixations; the communication to the public of their television broadcasts if such communication is made in places accessible to the public against payment of an entrance fee.

The Proposed Treaty on the Protection of Broadcasting Organizations

- Negotiations have started in the WIPO Standing Committee on Copyright and Related Rights already in 1999
- The main objective of the proposed treaty is to provide a stable legal framework for the broadcasting organisations
- Treaty seeks to update the rights of broadcasting organizations in response to new technologies- and fight signal piracy = **exploitation and misappropriation of broadcast signals by unauthorized third parties**

Why a Broadcasting Treaty?

- Laws are national : Address cross border piracy to allow broadcasters to sue in other countries where signal is pirated
- Broadcast signal to be protected from the moment it is created through primary use and against unlawful secondary exploitation
- Traditional broadcasters to be covered on all platforms of exploitations (technology neutral approach)

Protection of BO's

- The financial and organizational investment made for planning, producing, scheduling and disseminating signals to the public is recognized through a related right of the entrepreneurial effort
- In sports and news programming, where the value lies in the exclusive first transmission, it is vital for the broadcaster to be able to obtain an injunction immediately: rights in content not enough



Late 30's – Broadcasting boom!

Broadcast Piracy and Sport

- Broadcasting high-profile sporting events : core income generator for traditional broadcasters.
- Signal piracy impedes the broadcasters' ability to secure those rights - jeopardize the financial sustainability of sporting events.
- Important to take into account the investment required for providing the content
- The impact of technological development especially on the digital platform

Examples include the broadcasting of sporting events such as the Olympics, Cricket world Cup, FIFA World Cup among others.

Building Respect for IP

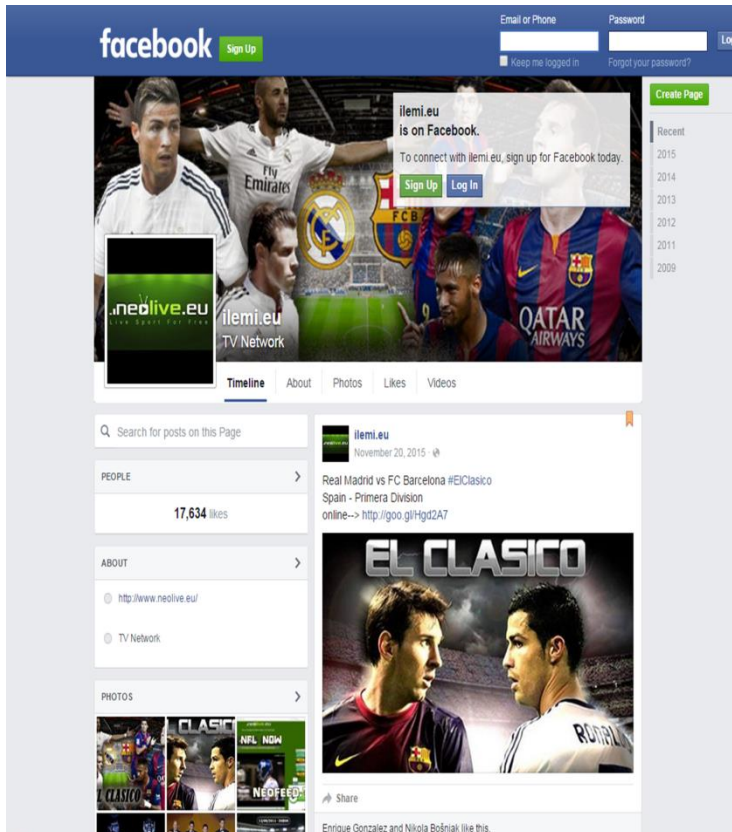

LOCAL GOVT & POLITICS



MORE THAN \$24 MILLION IN FAKE NFL MERCHANDISE SEIZED IN PAST YEAR

COBB POLICE DISCIPLINE DETECTIVE... →

Advisory Committee on Enforcement

Thirteenth Session – September 3-5, 2018

Fourteenth Session – September 2-4, 2019

- Three-day meeting
- Participants (members/observers)
- Speakers and panelists from all regions
- Side events
- Exhibitions
- All documents are available on line:
https://www.wipo.int/meetings/en/details.jsp?meeting_id=46432



Advisory Committee on Enforcement

Agreed work program:

- Exchange of information on national experiences on:
 - ❖ awareness building activities and strategic campaigns among general public, especially the youth
 - ❖ institutional arrangements for IP enforcement
 - ❖ WIPO's legislative assistance

- Exchange of success stories on capacity building and support from WIPO for training activities at national and regional levels for Agencies and national officials in line with relevant Development Agenda Recommendations and ACE mandate.

International Cooperation

Organizing global conferences on Respect for IP

- Global Congresses on Combating Counterfeiting and Piracy (2004 – 2013)
- International Conference on Building Respect for Intellectual Property - Stimulating Innovation and Creativity, Shanghai, China, November 17 and 18, 2016
- International Conference *Respect for IP – Growing from the Tip of Africa*, Sandton, South Africa, October 23 to 25, 2018



WIPO FOR OFFICIAL USE ONLY

Sport, IP and Development



Strategic Use of IPR

- Potential to support economic development in a variety of ways by:
 - Generating income from the sale of sports-related goods and services;
 - Supporting innovation and business growth, entrepreneurship and job creation;
 - Enhancing a country's reputation and boosting foreign exchange earnings;
 - Boosting international trade
- WIPO's role
- Advise Policymakers – how to integrate IP and sports-related objectives into national development plans/strategies
- Support the Development of an Enabling Regulatory Environment for IP
- Seminars/Trainings/Specific Capacity Building Activities

Raising Awareness – World IP Day 2019





World Intellectual Property Day – April 26, 2019

Reach for Gold: IP and Sports

Intellectual property and sports

Views from the world of sports



"As an athlete, I think IP rights and the protection of those rights is important... It allows me access to equipment, gear, and innovations that help me to perform better as an athlete and to achieve my sporting goals." – William Wainman, world-record freediver, ocean explorer and conservationist.

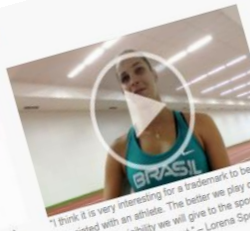

"I think it is very interesting for a trademark to be associated with an athlete. The better we play on track, the more visibility we will give to the sport, an exchange, a two-way street." – Lorena Soprano, Brazilian Paralympic sprinter.



"We believe that intellectual property is an important cornerstone of commercial sports, and hope that more brands, media, players, fans, and tournaments will join us with WIPO in thinking about and innovating how intellectual property can support the development of sports worldwide." – Alfred Zhang, Co-Tournament Director, China Open.



"Intellectual Property means it openly about our technologic innovations for the benefit of sports related injuries or..."



"Innovation is indispensable for a high level of sport. It improves performance, because products are lighter, much more efficient, and more accessible, even for the most specialized racers." – Jacques Bonilla, Product Manager, Movement Skis.



IP and the Olympic Games
There's more to the Olympic Games than star athletes: Have you ever thought about how IP rights help athletes compete, and even make the Games possible?



Understanding sports image rights
The commercialization of sports image rights is big business. But they are known by different names and subject to different legal treatment in different jurisdictions.



Team Antigua Island Girls: one of the toughest teams in the world
How technology and sponsorship enabled the first all-female Caribbean team to row across the Atlantic.



Ambush marketing: when sponsors cry "foul"
Sponsors pay hundreds of millions of dollars to showcase their brands at top sports events. What practical steps can sponsors take to safeguard their investment?



IP, sports and tourism
Sports tourism is growing fast, creating opportunities for nations to capitalize on their success in sports to promote social, economic and cultural development.



IP and sports products go hand in hand
Why IP rights matter for the sporting goods industry as well as for sports clubs, event organizers and consumers.



Copyright and sports broadcasting in Kenya
Globally, the rights associated with the broadcasting of sports events are not clear-cut. In many countries, including Kenya, court decisions form the basis of the



In depth: IP and sports
How IP rights support the world of sports – from sports federations to athletes and sports fans.



WIPO Magazine – special focus issue
Issue 2/2019 explores the connections between the worlds of IP and sports.

WIPO and sports

Cooperation Treaty and...
that have passed...
Patent System.

WIPO's Madrid System and sport brands
Sports-related trademarks and the International Trademark System.

WIPO's Hague System
Design innovations to surf...
explore the world underwater...
passed through the International System.

Solving IP and sports disputes
review of mediation, arbitration, and...
name disputes resolution services...
by the WIPO Arbitration and...
center.

Sports, IP and development
How strategic use of IP rights and WIPO...
initiatives support economic development.

FOLLOW US

■ Twitter @ wipo

■ Youtube Channel

<https://www.youtube.com/user/wipo>

■ WIPO Magazine

www.wipo.int/wipo_magazine/en/

■ WIPO WIRE

www.wipo.int/newsletters/en

■ PRESS RELEASES

www.wipo.int/pressroom/en/

■ WIPO IN 3 MINUTES

www.wipo.int/pressroom/en/news/2016/news_0009.html

