



Geneva, November 10, 2016

Experience From a Practitioner's point of View

Bernard Volken, Fuhrer Marbach & Partners, Berne/Switzerland
volken@fmp-law.ch

Table of contents

1. Introduction (legal assumption)
2. No principle of specialty!
3. No use obligation!
4. Specific issues: protection of trade dresses and logos
5. Parameter for a tailor-made filing strategy
6. Accession of examining member states
7. Practice/jurisdiction
8. Conclusion

1. Introduction

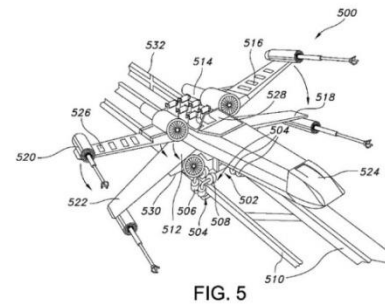

U.S. Patent
Sep. 26, 2010
Sheet 1 of 18
US 2009/232182

Patent (in most jurisdictions): examined
→ tendency to consider the patent as barely
attackable

1. Introduction



Design (in most jurisdictions) = not examined

→ tendency: design considered as being weak



The truth is in the middle

- Design protection is clearly underestimated
- Why: *legal presumption* of validity
➡ turn of the prove burden

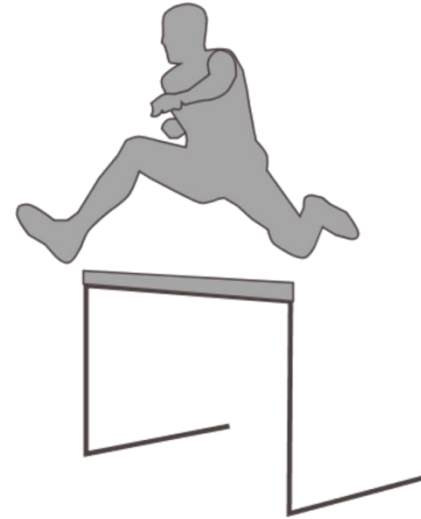



Swiss Federal Court,
July 13, 2004
“Pendant”

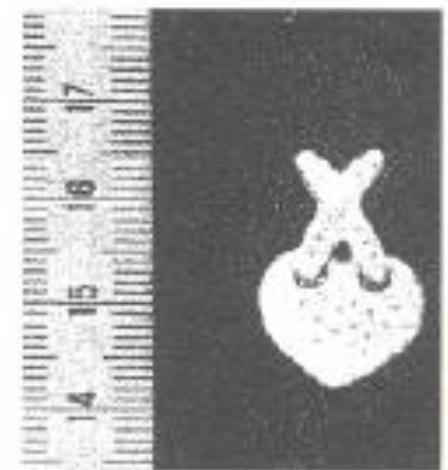

*Design infringement
affirmed!*

Plaintiff // Defendant



- Defendant failed in *proving lack of novelty*.
- Lack of novelty is irrelevant if not proved.
- “Missing examination” of a design is partially “compensated” by the legal presumption.

<i>Court</i>	<i>Plaintiff</i>	<i>Defendant</i>	<i>Decision</i>
<p>Copenhagen Maritime and Commercial Court</p> <p>(22 May 2008, No. V-0052-7)</p>	<p>Reisenthel Accessoires</p> 	<p>Zebra A/S</p> 	<p>Infringement affirmed. Defendant had to pay damages.</p>

<i>Court</i>	<i>Plaintiff</i>	<i>Defendant</i>	<i>Decision</i>
<p>Copenhagen Maritime and Commercial Court</p> <p>(25 Jan 2008, No. V. 68/06)</p>	<p>Staff ApS</p> 	<p>Marc Lauge A/S</p> <p>Confusingly similar trousers</p> 	<p>Infringement affirmed. Defendant had to pay damages.</p>

Court of Justice of the European Union (CJEU) C-345/13 Karen Millen vs. Dunnes, Decision 19 June 2014

Karen Millen



Dunnes
(Savida label)



Karen Millen



Dunnes
(Savida label)



(Irish High Court, unregistered Community design rights).

“The right holder of a design is not required to prove that it has individual character”.



= right holder is released from burden of prove regarding existing novelty!

(interpretation of the General Court of article 85 II of Regulation 6/2002 [presumption of validity - defense as to the merits])

Legal presumption = advantage in case of conflict

- for sending cease and desist letters,
- and in case of preliminary injunctions

and for negotiating licenses.

2. No principle of specialty

Art. 2 I Locarno Classification: “Subject to the requirements prescribed by this Agreement, the international classification shall be solely of an administrative character. Nevertheless, each country may attribute to it the legal scope which it considers appropriate. In particular, the international classification shall not bind the countries of the Special Union as regards the nature and scope of the protection afforded to the design in those countries.”

Decision by the UK Court of Appeals (23. April 2008)

Spiky balls for use as laundry aids,
registered designs under Nos.
000217187-0001 – 004;
application date 2004:

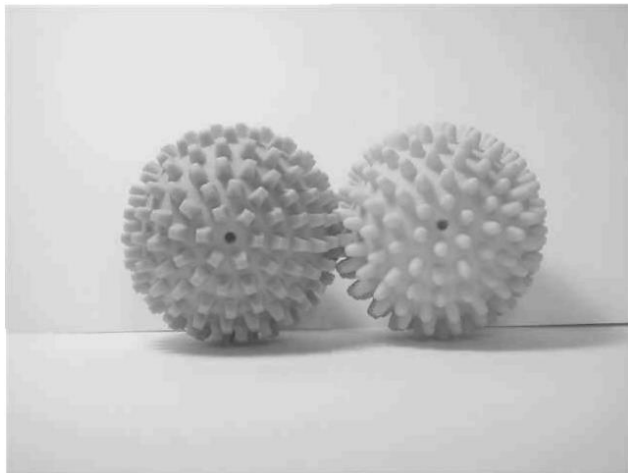

Sold and used as a
massage ball since
2002:



The parties settled the case amicability. However, one of the judges argued:

“...this case gives rise to points of law of general importance which have an impact on those not directly engaged in this particular dispute. Where our judgment may clarify that which has been moot and the result is of wider public interest, I take the view that we should make our conclusions known and so I have been in favour in this case of handing down this judgment.”

The Court stated:



“the right gives a monopoly over any kind of goods according to the design. It makes complete sense that the prior art available for attacking novelty should also extend to all kinds of goods”.

3. No use requirements!!

Trademarks registered for 45 classes: often confronted with “defensive trademark jurisdiction”

Problem solved with design:

- no principle of specialty
- no use obligation!

Monopoly  *“corrective against abuse”*

Design

- no “principle of specialty”, no “use obligation” = huge scope of protection
- → Corrective: time limitation.

Trademark

- Timely unlimited
- → corrective: “principle of specialty” and “use obligation”

4. Protection of Trade dresses and logos

“An industrial design may consist of three dimensional features, such as the shape of an article, ...”.

(<http://www.wipo.int/designs/en>)

*Trade dresses –
unfair competition and design protection*

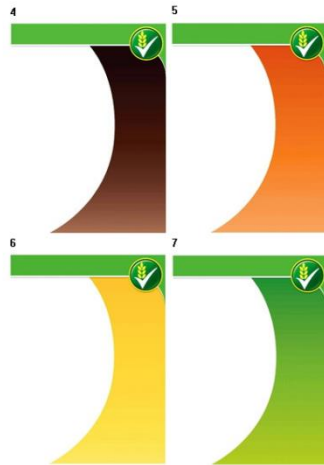

Nestlé DM/077205

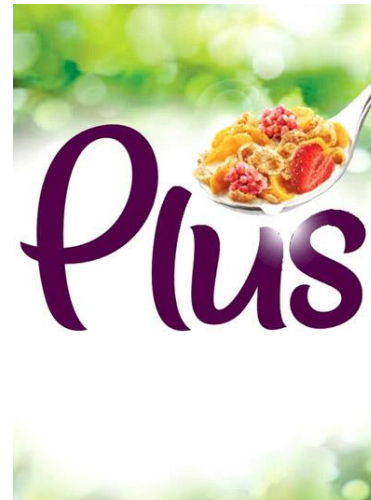

Nestlé DM/074008

Protection of Logos: Locarno class 32-00

- 9th Locarno edition (1st January 2009): „*graphic symbols and logos*“.
- Some Trademark Offices were reserved regarding logo-filings, what now is no longer the case. As a matter of fact, the number of logo applications significantly increased since 2009 in most jurisdictions.



DM/078389

BUNDESREPUBLIK
DEUTSCHLAND



DM/078399



TM IR 1124274

no principle of specialty
+
no use requirement
+
legal presumption
+
tailor made filing strategy
=
strong IP right / trump

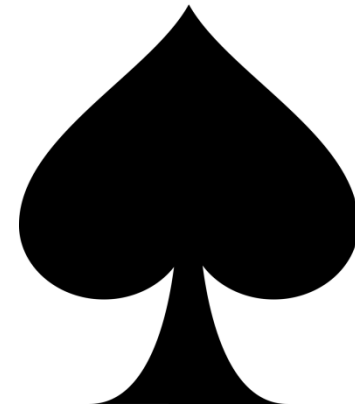

5. Parameter for a tailor-made filing strategy

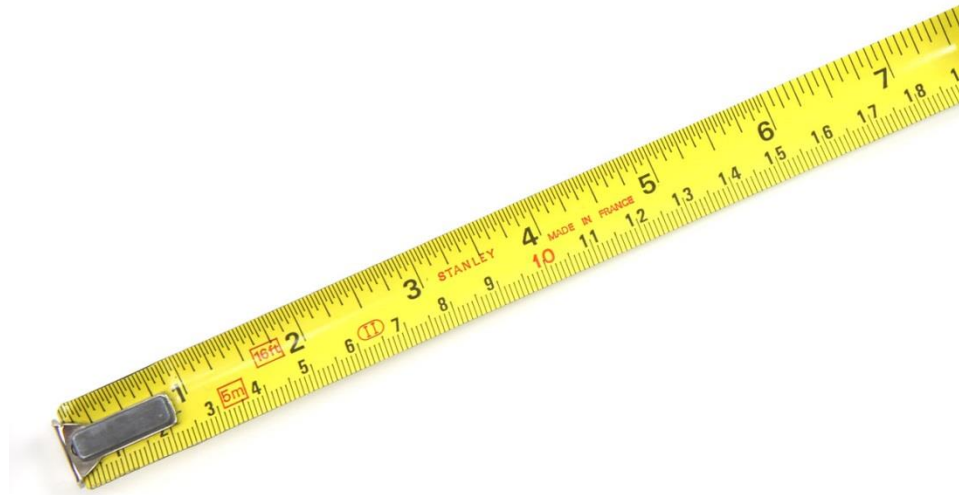

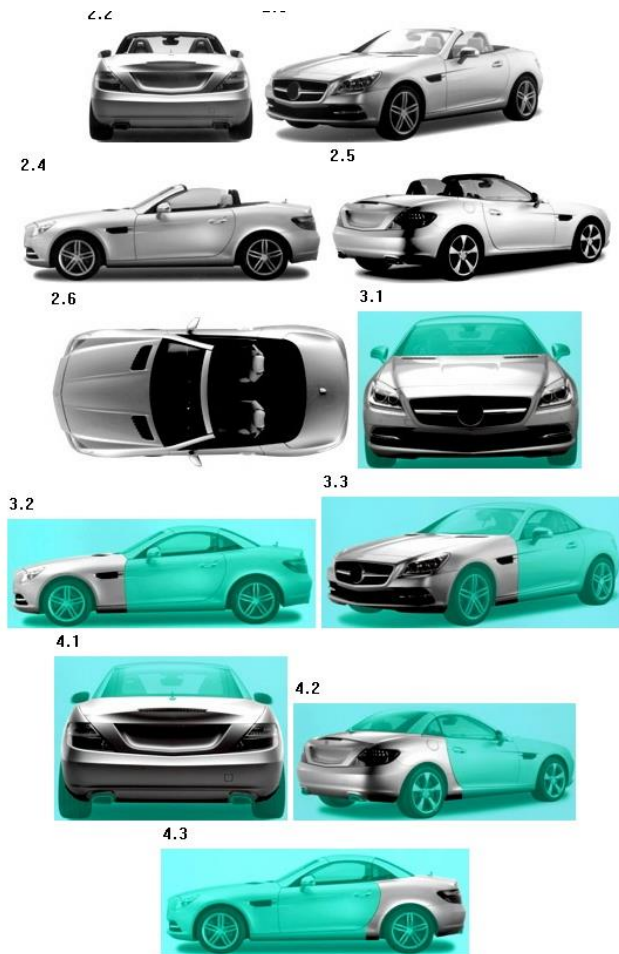

Combination “different perspectives” + disclaimer

DM/070912
Daimler AG



disclaimer



DM/076650 Daimler AG

“The blue marked areas are not coming into the scope of protection, they have the function of a disclaimer”

15.2



DM/076222

The blue marked parts of designs 8, 9, 10, 11, 12, 13 and 14 are not coming into the scope of the industrial design (disclaimer)

1



DM/075740

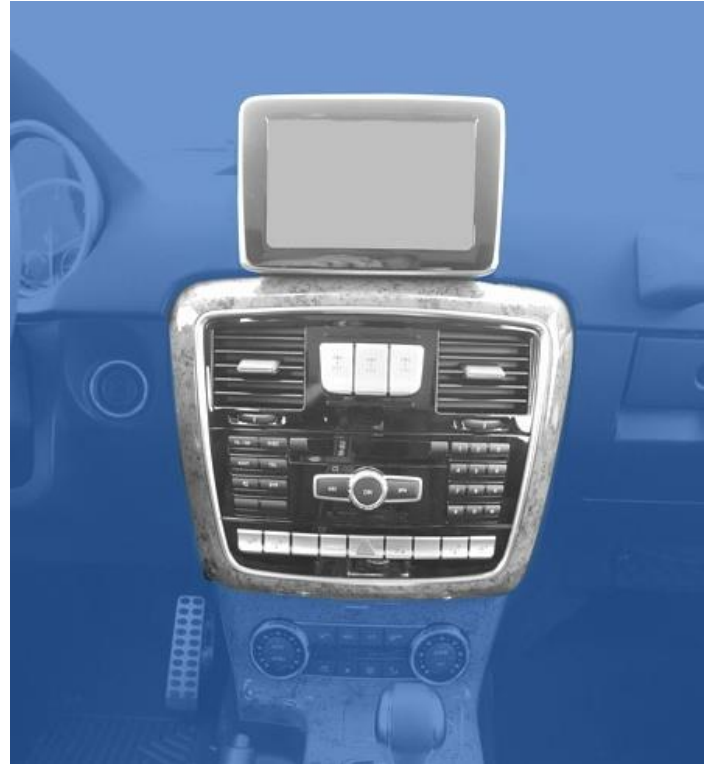

1.1



1.2



1.4



1.3



1.5



1.6

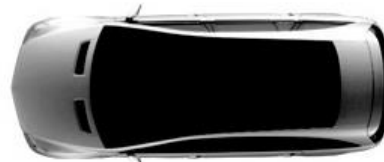

different perspectives

DM/071034
Daimler AG

Photography or graphical reproduction?

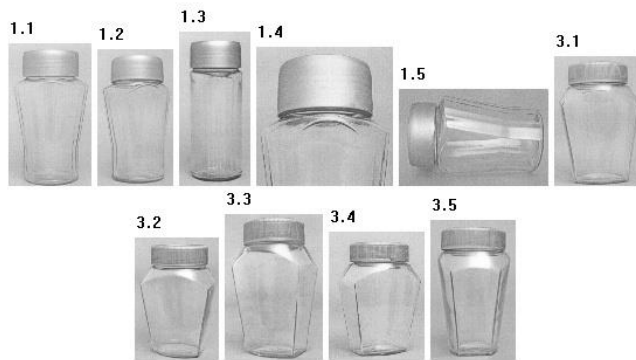

DM/066980 (15); Lidl, DE

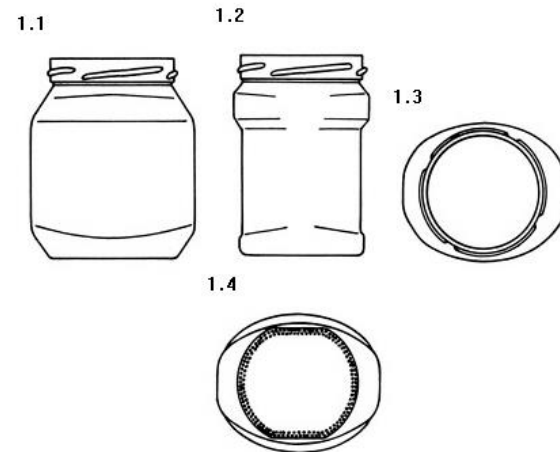

DM/066875 (15), Lidl, DE

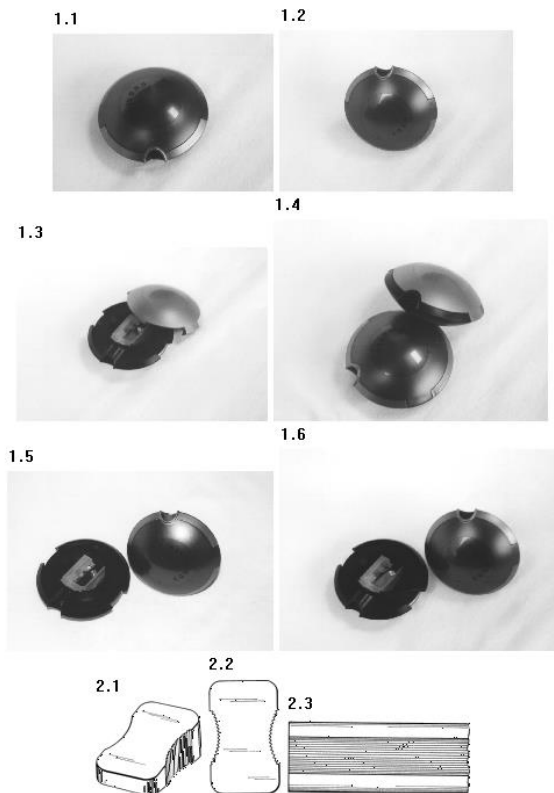

*Combination of photography
and graphical reproduction!*

DM/052026 (15);
EISEN GMBH, DE

Color and/or black and white?



3.1

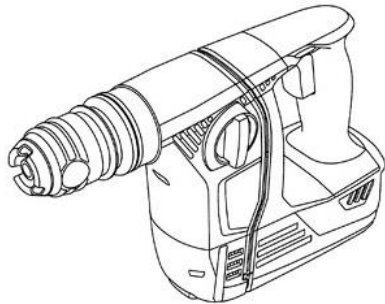

3.2

DM/075961 (15); Hilti, LI



2.1

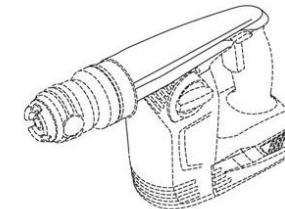

2.2

DM/076048 (15); Hilti, LI

Whole product and/or parts thereof?

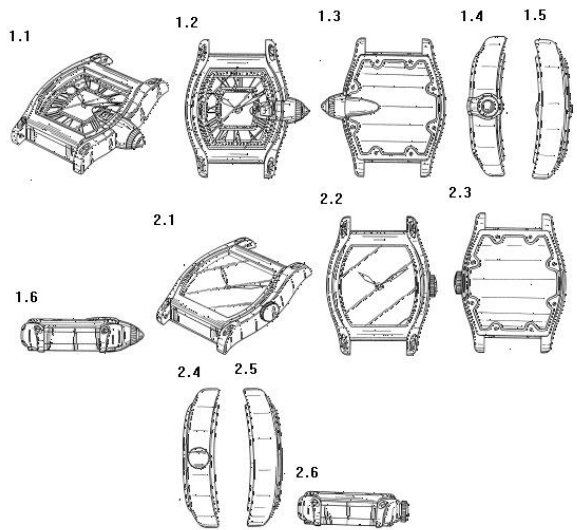

DM/047327 (15); Cartier; CH



DM/071188 (15); Cartier, CH

100 words description?

(11) DM/075296 (15) 10.02.2011 (18) 10.02.2016

(22) 03.11.2010 (73) **CARTIER** CREATION STUDIO S.A., Boulevard James-Fazy 8, CH-1201 Genève (CH) (86)(87)(88)(85) CH (89) CH (74) GRIFFES CONSULTING SA Route de Florissant 81, CH-1206 Geneva (CH) (28) 8 (51) Cl. 09-01, 07 (54) 1.-4. Perfume bottles; 5.-8. Caps for perfume bottles / 1.-4. Flacons de parfum; 5.-8. Bouchons pour flacons de parfum / 1.-4. Frascos de perfume; 5.-8. Tapas de frascos de perfume (57)(55)

Design 1: bottle of perfume with its cap closed; the bottle with its cap forms an overall oval cylinder; the bottle cap is linked to the main cylinder by a single binding element; the top part of the cap is domed; the bottle features an horizontal line on its lower part; Design 2: bottle of perfume with its cap open; the bottle forms an overall oval cylinder; the open bottle's cap shows a large and flat topped sprayer that has an oval shape; the base of the sprayer is narrow compared to its upper part; the top part of the cap is domed; the bottle features an horizontal line on its lower part; Design 3: bottle of perfume with its cap closed; the bottle with its cap closed forms an overall oval cylinder; the bottle's cap which is domed on its top part is linked to the main cylinder by a single binding element; Design 4: bottle of perfume with its cap open; the bottle forms an overall oval cylinder; the bottle's cap which is domed on its top part is linked to the main cylinder by a single binding element; the open bottle's cap shows a large and flat topped sprayer that has an oval shape; the base of the sprayer is narrow compared to its upper part; Design 5: cap closed for a bottle of perfume; the cap forms an oval cylinder; the upper part of the cap is domed; the cap is linked to the main cylinder by a single binding element; Design 6: open cap for a bottle of perfume; the cap forms an oval cylinder; the upper part of the cap is domed; the cap is linked to the main cylinder by a single binding element; the open cap shows a large and flat topped sprayer that has an oval shape: the base of the sprayer is narrow compared to its upper part; Design 7: cap

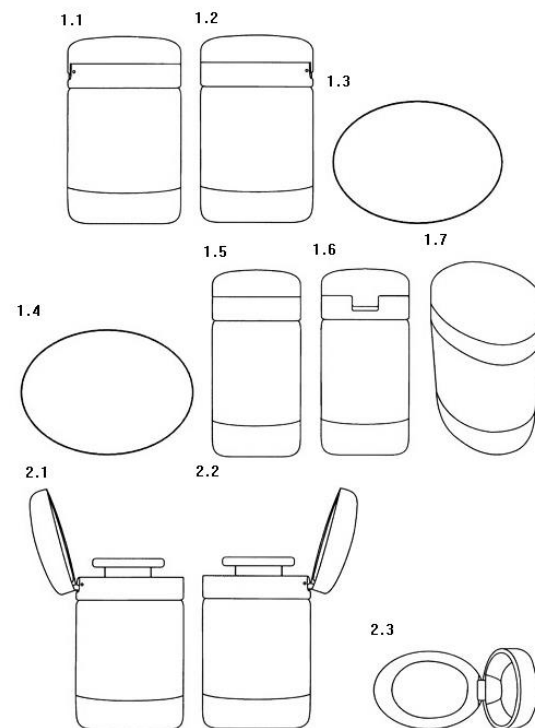

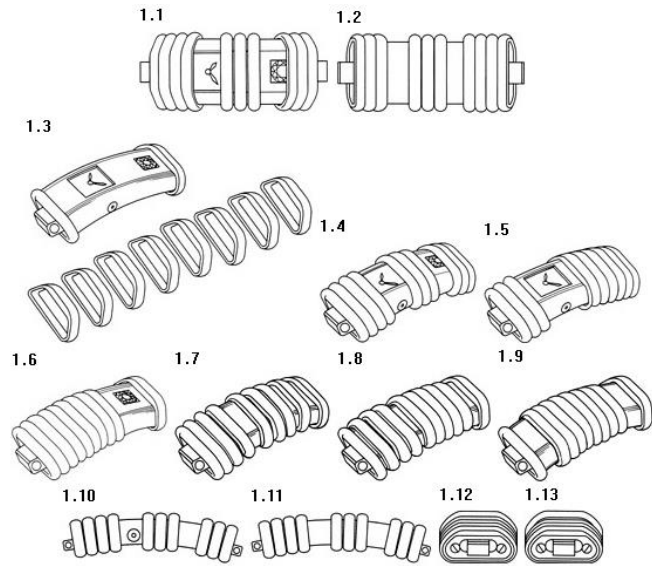

*One picture can say more
than 100 words.*

DM/062910 (15); Cartier, CH

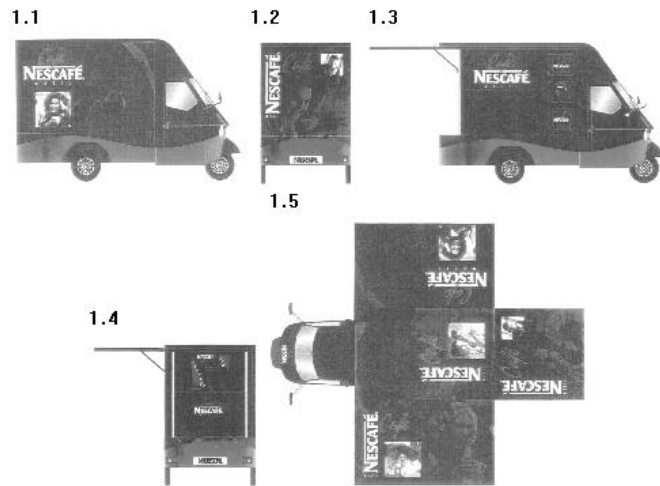

*One picture can say
more than 100 words.*

DM/047707 (15); Nestlé, CH

6. Accession of examining member states

Countries with examination

- Japan: declaration three-dimensional

“a front view, a back view, a top view, a bottom view, a left side view and a right side view, each made in compliance with the method of orthographic projection are required“

Accession USA, Japan and the Republic of Korea – consequences for practitioners

- USA: no color drawings or color photographs & it is not possible for an applicant to request the deferment of publication.
- Republic of Korea: specific views are required: (i) for a design of a set of articles: one view of the coordinated whole and corresponding views of each of its components, and (ii) for a design for typefaces: views of the given characters, a sample sentence, and typical characters.

Formal or material law?

Requirements for receiving filing date?

- OMPI: formal examination. Are these specific requirements formal or material law?
- Decided by respective Court.



Decisive question

- Requirements for receiving the filing date.
- Example



(My) solution







- Before filing: local representative.
- Hague still attractive?
- Yes definitely: costs of local representative occur only once (for 25 years protection)
- Hague advantages remain: 1 registration, 1 currency, easy administration, still saving costs etc.
- But: responsibility of representatives to inform clients of these additional costs.

7. Practice/jurisdiction

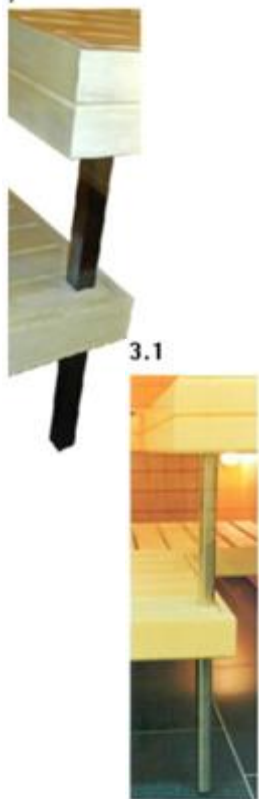
Does it work in practice - what about jurisdiction?

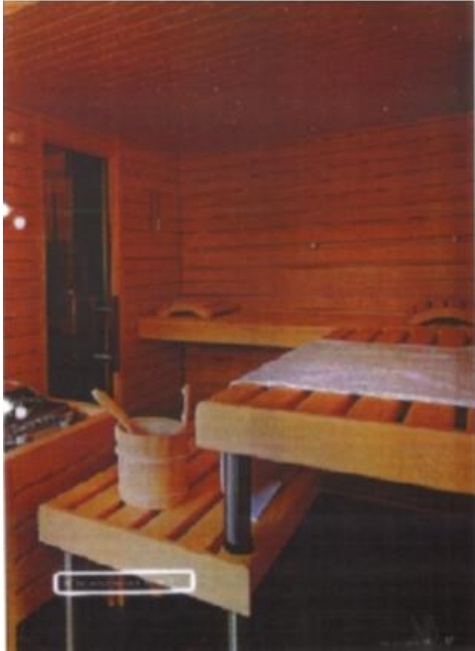

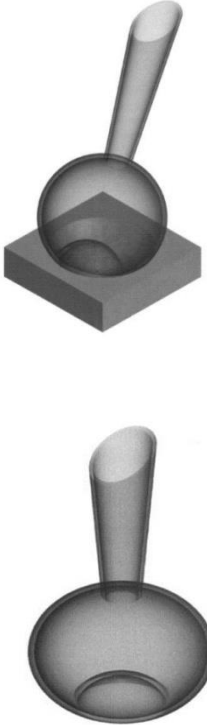
<i>Court</i>	<i>Plaintiff</i>	<i>Defendant</i>	<i>Decision</i>
<p>Swiss Federal Court</p> <p>(25 Mai 2016, No. 4A_44/2016)</p>	<p>Plaintiff holds Designs showing Sauna and Sauna parts:</p> 		<p>Due to the prior publication in a catalogue from the year 2009 showing the picture below, the Court denied the individual character (material novelty) of the plaintiffs designs:</p>  <p>➤ The appeal was rejected.</p>

<i>Court</i>	<i>Plaintiff</i>	<i>Defendant</i>	<i>Decision</i>
<p>BGH</p> <p>(8 March 2012, No. I ZR 124/10)</p>			<p>Infringement denied.</p> <p>Plaintiff's Design Registrations</p> <ul style="list-style-type: none"> •7 pictures of wine carafe. •4 with socket •3 without socket <p>Parts or elements of a Design Registration are not protected separately. As a result: the design protection covers “carafe with socket” and not its part (= carafe without socket).</p> <p>Be careful of the filing strategy!! Two filings: actions would have affirmed!</p>

General Court T-339/12

Fauteuil cubique, Decision dated 4 February 2014

Earlier design

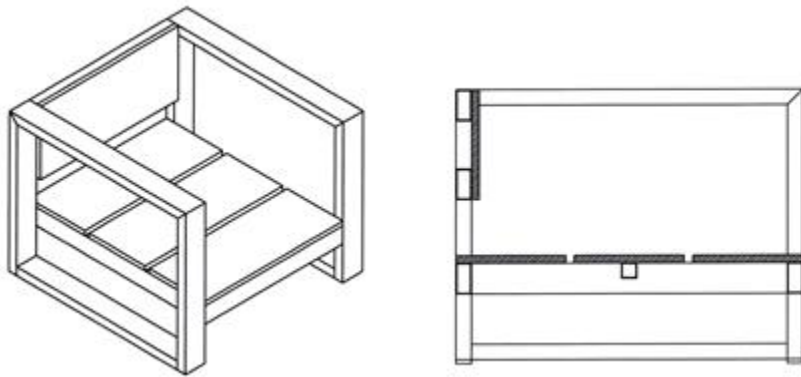

Contested design

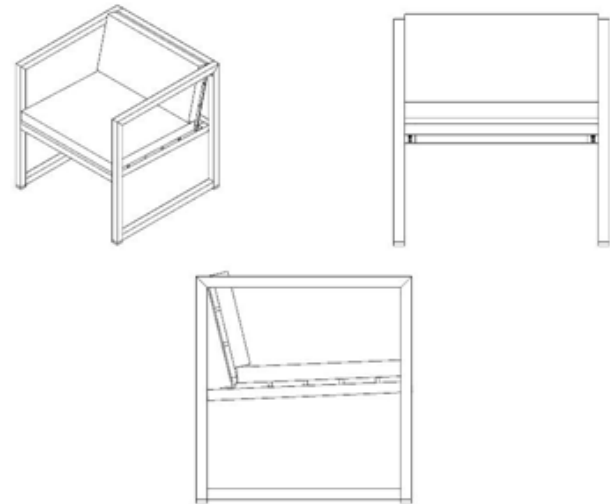



→ Differences in: seat height, seat and back inclination.

General Court:

Overall impression produced on the informed user must be determined based on **how the product is used**: differences in design lead to **different level of comfort**”.

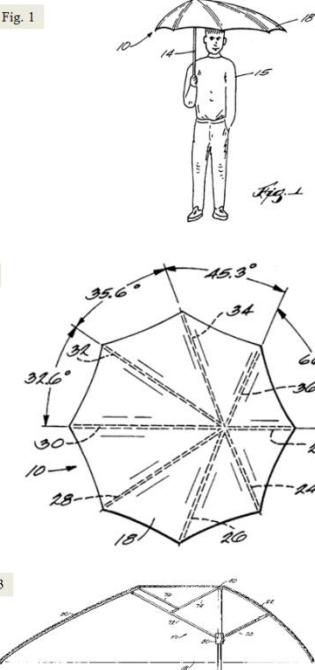

Action dismissed.

<i>Court</i>	<i>Applicant</i>	<i>Intervener</i>	<i>Decision</i>
<p>ECJ 21 May 2015, T-22/13 and T-23/13</p> 	<p>Senz Technologies BV</p> 	<p>Impliva BV</p> 	<p>Defendant based on a prior Patent registration.</p> <p>Court: different overall impressions and individual character.</p>

<i>Court</i>	<i>Plaintiff</i>	<i>Defendant</i>	<i>Decision</i>
<p>Tribunal de Grande Instance, Paris (18 December 2014, 13/04545)</p> 	<p>ELEVEN produced t-shirts with celebrities (here: Rihanna).</p>	<p>HK & CITY sold identical t-shirts.</p>	<p>The Court based on the “Unregistered Community Design” and affirmed the design infringement.</p> <p>(Copyright infringement was affirmed, too).</p> <p>➡ The case was solved based on design law (and not personality rights).</p>

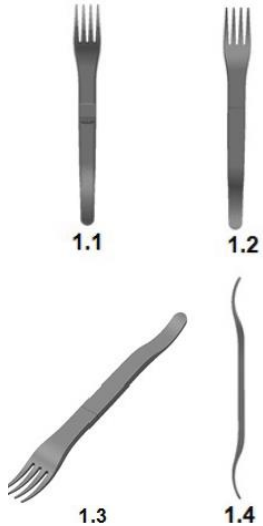
<i>Court</i>	<i>Plaintiff</i>	<i>Defendant</i>	<i>Decision</i>
<p>Court of Appeal of Paris</p> <p>(05 December 2014, 14/03506)</p> 	<p>Europlastic's Holder of two (registered) Community designs</p> 	<p>GERMAY PLASTIC</p>	<p>- Court assessed plaintiff's design as valid.</p> <p>- Defendant failed in proving lack of novelty (see next slide)</p> <p>➡ design infringement affirmed</p>

Prior art:
US D535 857

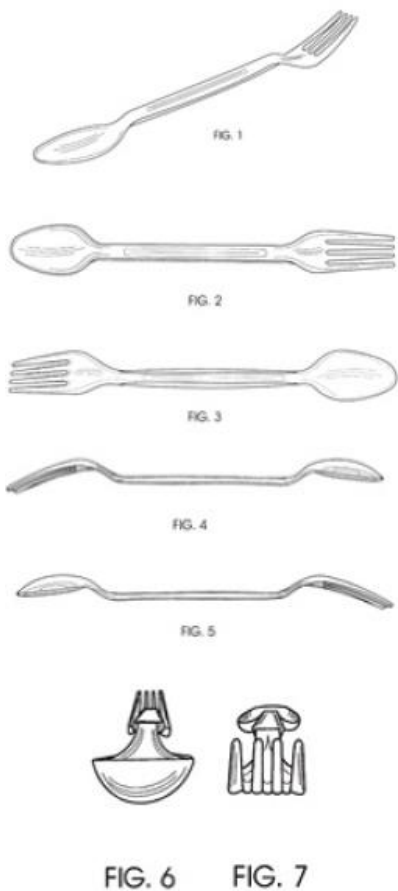

DE 298 11 134 U1

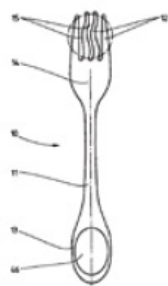

US Des. 325,855

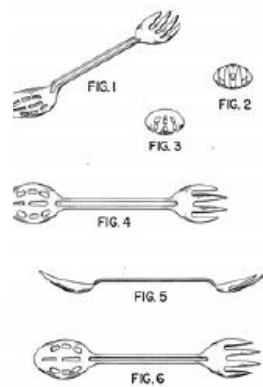

US 7.162,802 B2

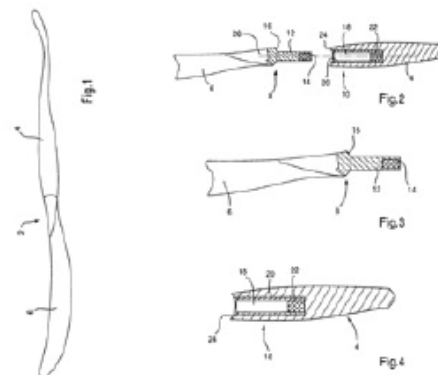

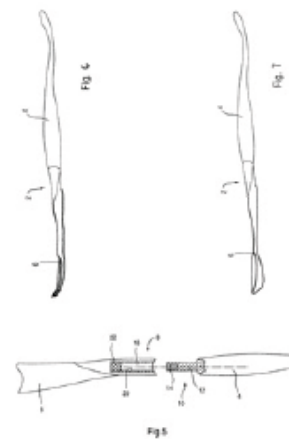
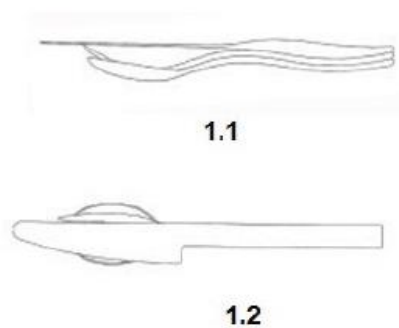

RCD 000005517-0001

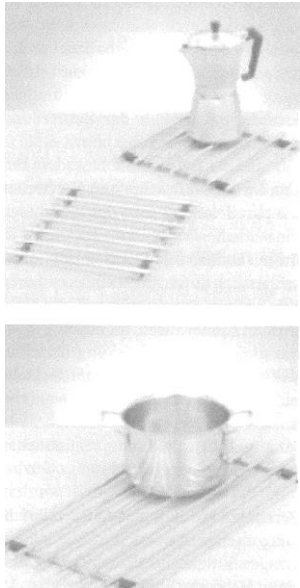
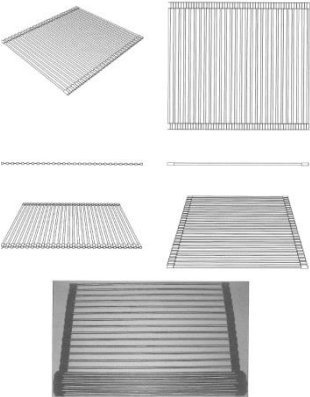
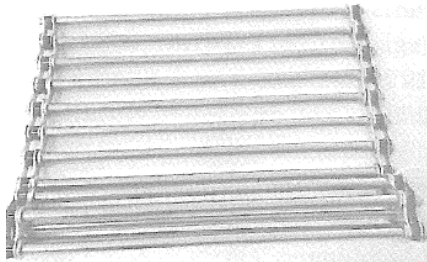

<i>Court</i>	<i>Appellant</i>	<i>Intervener</i>	<i>Decision</i>
GC (9 September 2014, Case T- 494/12)	RCD application 	Applied for a declaration of invalidity	<ul style="list-style-type: none"> • Non-visible characteristic of the product does not relate to the appearance. • Applicant misunderstood Article 4 (2) and (3) RCDR (requirements for protection). <p>➡ registration refused.</p>

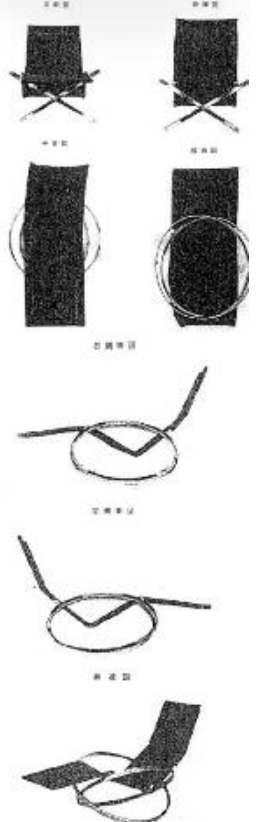
<i>Court</i>	<i>Plaintiff</i>	<i>Defendant</i>	<i>Decision</i>
<p>Commercial Court of Aargau (5 March 2014)</p>	<p>Pan mat</p> 	<p>Dishes drip device</p> 	<p>Rejection: different overall impressions.</p> <p>Bonding of the disputed product look like a bicycle chain. This strongly influences the disputed product and gives it a different overall impressions.</p> 

<i>Court</i>	<i>Appellant</i>	<i>Respondent</i>	<i>Decision</i>
<p>BoA</p> <p>(14 June 2012, Case R 2194/2010-3)</p>	 <p>000.1.1</p> <p>000.1.2 000.1.3</p> <p>000.1.4</p> <p>000.1.5 000.1.6</p> <p>000.1.7</p>		<p>Respondent destroyed novelty based on a Japanese patent.</p> <p>➡ <u><i>RCD declared invalid.</i></u></p>

<i>Court</i>	<i>Design Holder</i>	<i>Invalidity Applicant</i>	<i>Decision</i>
<p>BoA (10 October 2014, Case R 1682/201-3)</p> 	RCD	<p>Filed application for a declaration of invalidity based on earlier intern. trademark</p> 	<p>Trademark information on the packaging not relevant for consumer.</p> <p>➔ <u>RCD declared invalid.</u></p>

<i>Court</i>	<i>Plaintiff</i>	<i>Defendant</i>	<i>Decision</i>
<p>Oberlandsgericht Düsseldorf</p> <p>(24 July 2012, No. I-20 U 52/12)</p>	<p>Dr. Oetker reg. design:</p>  <p>Trade dress:</p> 	<p>Aldi Infringing product:</p>  <p>Trade dress:</p> 	<p>Infringement denied.</p> <p>Different overall impressions: “Spiral element/movement impression” of the plaintiff design is missing.</p> <p>Limited scope of protection of the plaintiff’s design?</p>

Design protection is like a unicycle:

not easy to ride, but if you manage it, it's a lot of power and flexibility!



Thank you!

