

Tips!!!

for Successful Filing Strategies Under the Hague System

All in One: Designating Canada, the European Union, Japan, the Republic of Korea, the Russian Federation and the United States of America in the international application

Päivi Lähdesmäki
Senior Advisor
The Hague Registry
Brands and Designs Sector

Geneva
June 6, 2019

Contents

- *What is an Examining Office Under the Hague System?*
- *Recent Developments*
- *Avoiding Possible Refusals:*
 - *Insufficient Disclosure*
 - *Unity of Design*
 - *Conflict Applications / Registrations*
 - *Lack of Novelty*
 - *Product Indication*
 - *Submission of Priority Documents to JPO, KIPO and ROSPATENT*
- *Few Incentives*

What is an Examining Office under the Hague System?

■ Article 1(1)(xvii) of the 1999 Act

- Some declarations are open only to a Contracting Party whose Office is an “Examining Office”. Those declarations are namely:
 - declaration under Article 5(2) (Additional mandatory contents of the International Application),
 - declaration under Article 7(2) (Individual designation fee),
 - declaration under Article 14(3) (Prohibition of self-designation), and
 - declaration under Rule 18(1)(b) (Extension to 12 months of the refusal period)*.

* in addition to jurisdictions which provide for an opposition

What is an Examining Office under the Hague System

■ Qualifying as an Examining Office:

Examining Office” means an Office which ***ex officio*** examines

(1.) all applications filed with it for the protection of industrial designs

(2.) before the grant of protection

(3.) systematically

(4.) according to the laws of the Contracting Party,

(5.) at least to determine whether the industrial designs satisfy the condition of novelty

What is an Examining Office under the Hague System

■ Note in the meeting document at the Diplomatic Conference

1.10 Item (xv). The term “Examining Office” refers to an Office which ***ex officio*** carries out a substantive examination of applications - that is to say with regard to **novelty** and, possibly, other substantive requirements such as originality or non-functionality.

Document H/DC/5, “Notes on the Basic Proposal for the New Act of the Hague Agreement Concerning the International Registration of Industrial Designs”

Recent Developments

■ Notifications of Refusal Received

■ 2018: record number of refusals **3,414**

■ 2017: 3,389

■ 2016: 1,974

■ 2015: 199

■ 2014: 152

Note: Counts are based on refusal notifications recorded by the IB

Recent Developments (cont.)

■ Russian Federation (entry into force on February 28, 2018)

- Refusals by Rospatent (by the end of 2018): **147**

■ Canada (entry into force on November 5, 2018)

- No refusals yet received;
- First refusals from CIPO expected in the second half of 2019

Recent Developments (cont.)

Refusal Grounds

USPTO, JPO, KIPO & ROSPATENT
 Refusal Grounds per Designs, up to December 31, 2018

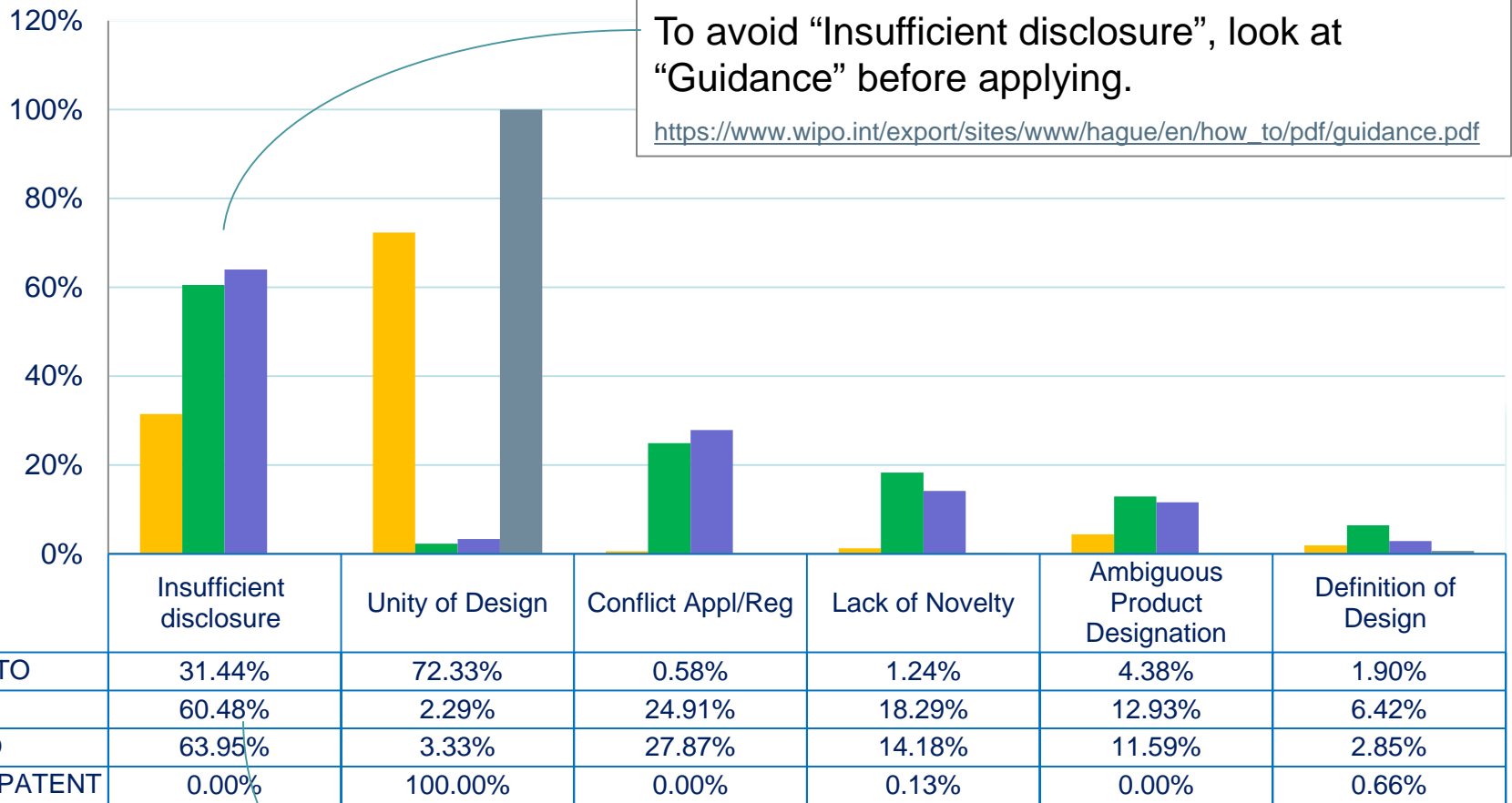

To avoid “Insufficient disclosure”, look at “Guidance” before applying.
https://www.wipo.int/export/sites/www/hague/en/how_to/pdf/guidance.pdf

*Recent news (May 20, 2019)
 Japan relaxes its requirements regarding views
https://www.wipo.int/hague/en/news/2019/news_0006.html



Avoiding possible refusals:

Insufficient disclosure

Rule 9(4) of the Common Regulations

- No refusal on formal grounds.
- Refusal possible on the ground «*that the reproductions contained in the international registration are not sufficient to disclose fully the industrial design*».
- Criteria for sufficient disclosure of an industrial design may be different from one jurisdiction to another.

Guidance on Reproductions

Media
Meetings
Contact Us
My Account
English ▾

WIPO
WORLD INTELLECTUAL PROPERTY ORGANIZATION

IP Services
Policy
Cooperation
Knowledge
About

Home > IP Services > Hague System
🔍

WIPO | HAGUE

Hague – The International Design System

The Hague System for the International Registration of Industrial Designs provides a practical business solution for over 100 designs in 69 contracting parties through international application.

Find out more

- [What is an industrial design?](#)
- [Main features and advantages](#)
- [Legal framework](#)
- [Frequently asked questions](#)
- [Guidance on reproductions](#) **PDF**



November 2018

Guidance on Preparing and Providing Reproductions in Order to Forestall Possible Refusals on the Ground of Insufficient Disclosure of an Industrial Design by Examining Offices

(Rule 9(4) of the Common Regulations under the 1999 Act and the 1960 Act of the Hague Agreement)

GENERAL DISCLAIMER:

This Guidance is prepared in consultation with the Examining Offices under the Hague System. The purpose of this guidance is neither to be self-sufficient nor all inclusive; each guidance focuses on a separate issue elaborating ways to help the applicant to avoid a possible refusal. A table at the end of this Guidance indicates whether a specific guidance is recommended by a given Examining Office.

https://www.wipo.int/export/sites/www/hague/en/how_to/pdf/guidance.pdf

WIPO | HAGUE
The International
Design System

Provide Enough Views

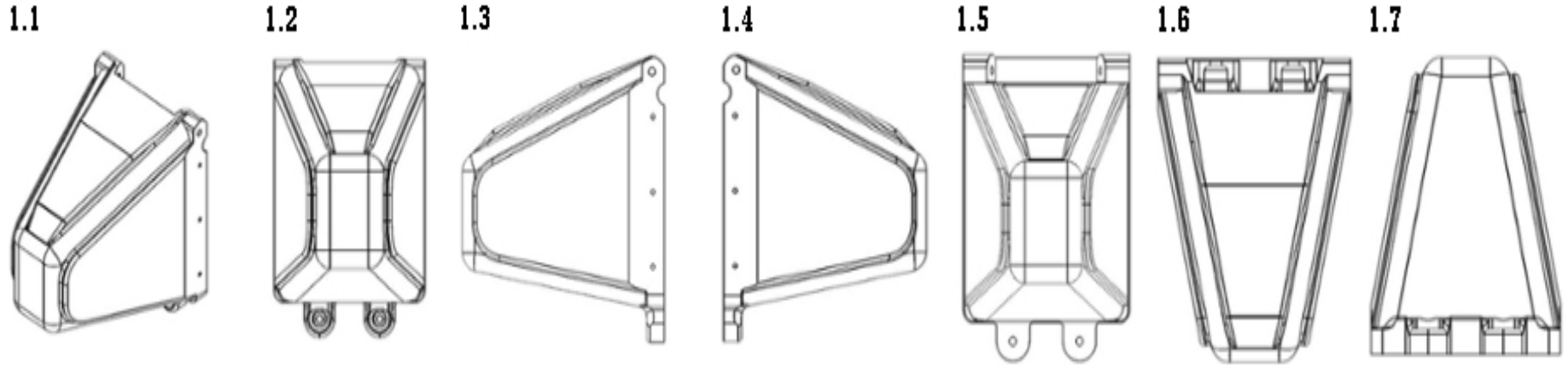

1.1) Perspective; 1.2) Front; 1.3) Left; 1.4) Right; 1.5) Back; 1.6) Top; 1.7) Bottom

[DM/092 108](#) for a “Security bulwark”

It's Always Safer with a Legend

Use the «description» to justify absent views

- DM/088980: “front view is omitted because it is identical with the back view; right side view is omitted because it is identical with the left side view”

1.1



1.1) Perspective

1.2



1.2) Perspective

1.3

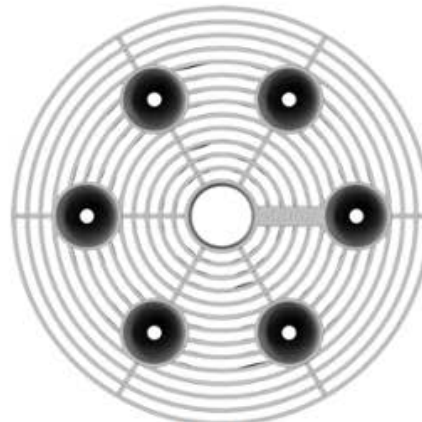

1.3) Top

1.4

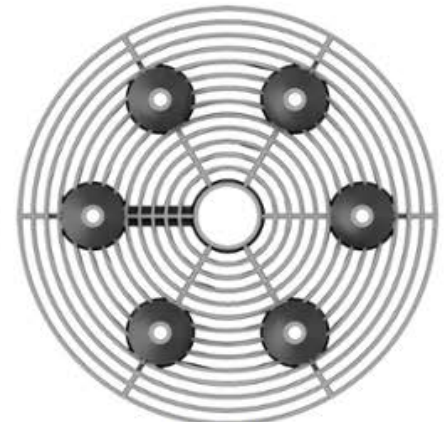

1.4) Bottom

1.5



1.5) Left

1.6



1.6) Back

What Went Wrong Here?

2.1



2.2



2.3



2.4



2.5



2.6



2.7



DM/90873 «Wallet»

2.1) Perspective; 2.2) Front; 2.3) Left; 2.4) Back; 2.5) Right; 2.6) Top; 2.7) Bottom

2.1



2.1) Perspective

JPO Refused because...

The design in this application for design registration is not a specific design because of the following reason:

The state of use and the method of use of "Wallet" as shown in the indication of product in this application for design registration cannot be derived from the reproductions, and the design is not specific.

(The method on how to fold "Wallet" and the state where it is folded are not clear. It is also not clear whether the lines shown on the surface of "Wallet" indicate a pattern or card slots.)

Shading lines not explained = Refusal

Refusal by JPO: A single definite design cannot be identified.

Thin lines are shown on the surface in the reproduction of this design; however, the meaning of these lines is not stated in DESCRIPTION.

Accordingly, it is unclear whether these thin lines constitute surface pattern or not.

1.1

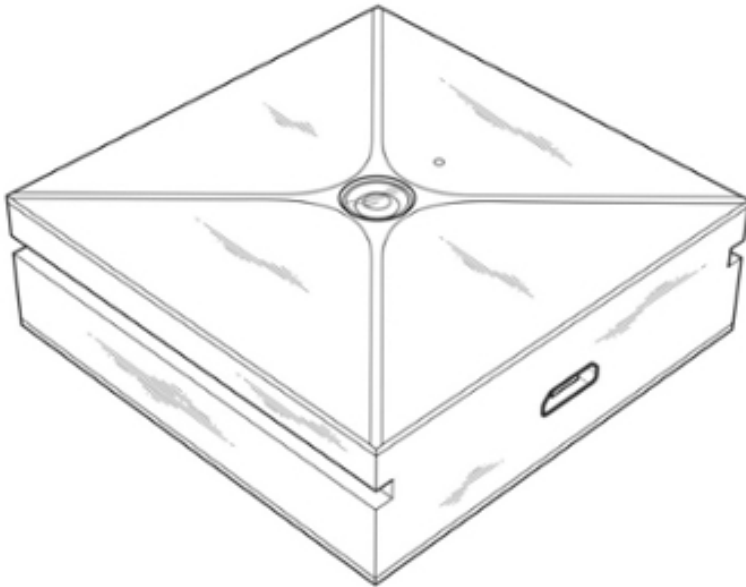

1.2

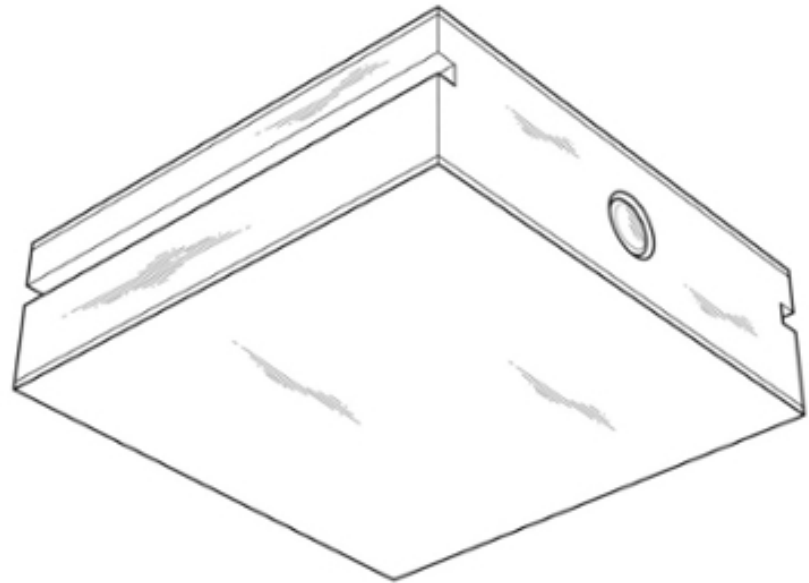

Also Explain Presence of Dotted Lines

1.3

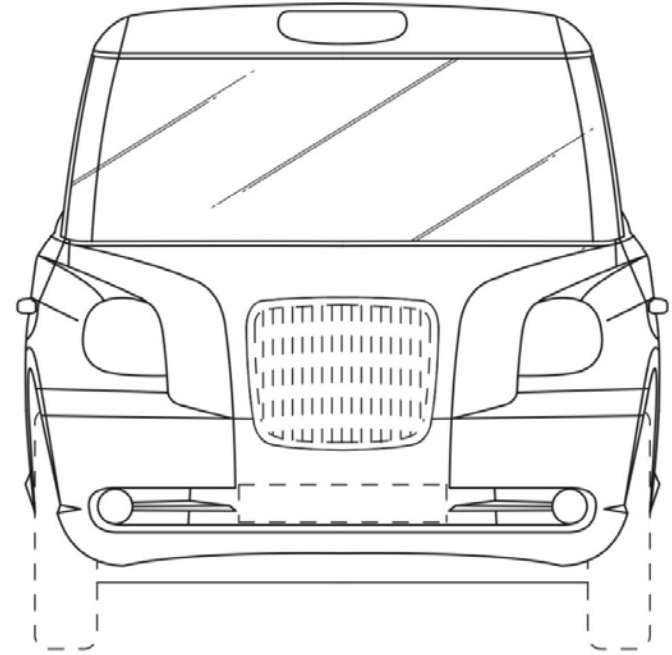
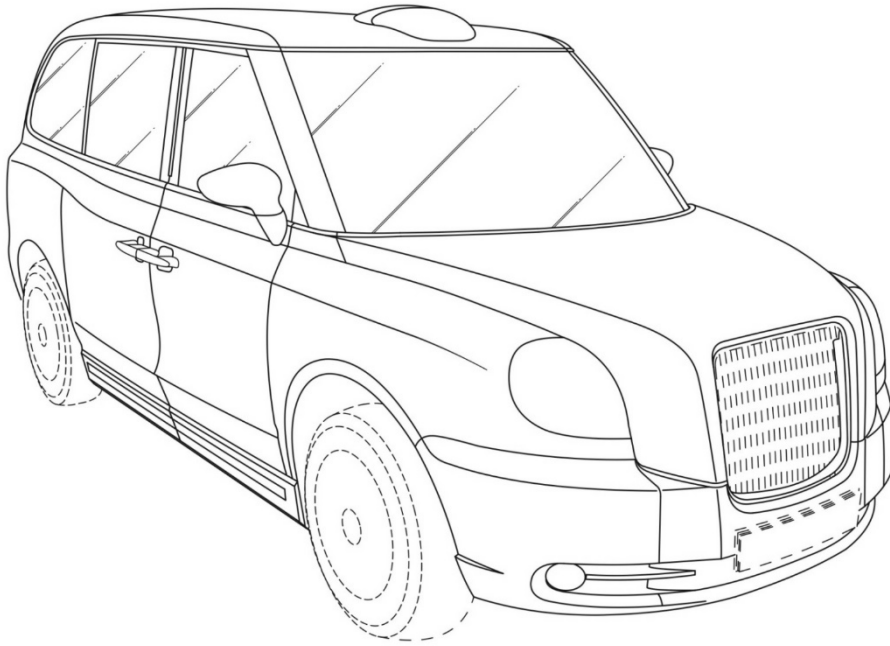

DM/91054 -

“No protection is sought for the matters shown in dotted lines”

Be consistent amongst all views

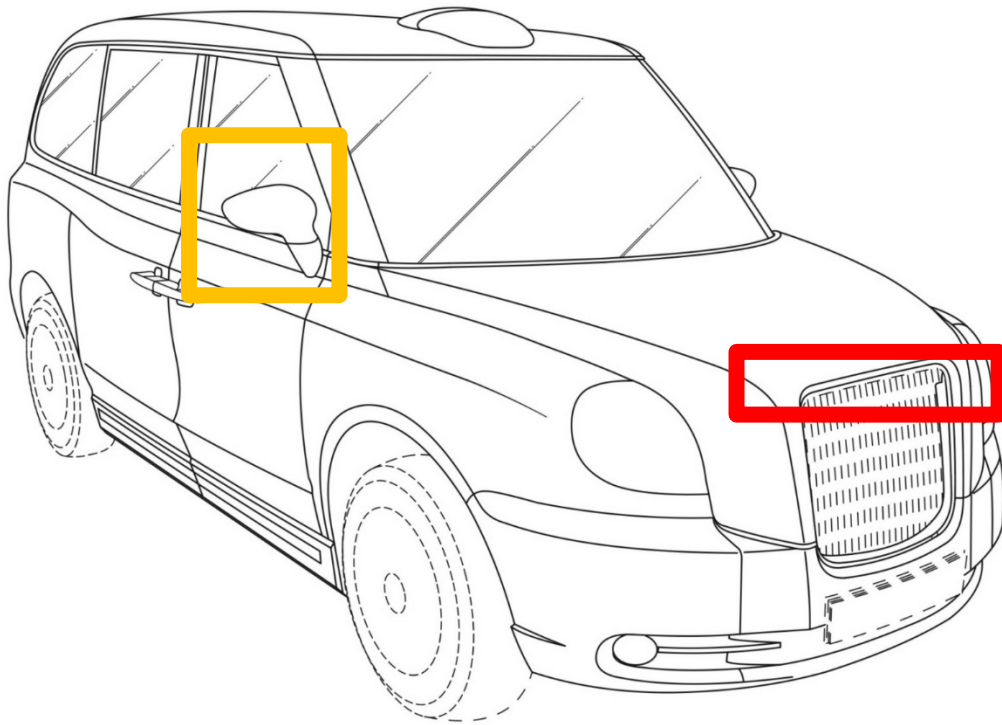

1.3

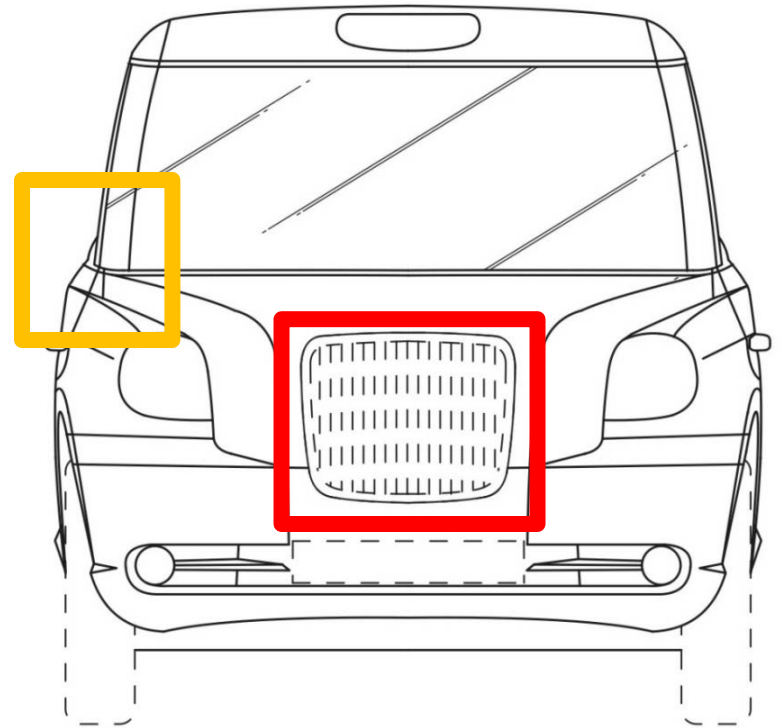

Avoid mixing reproduction styles

1.1

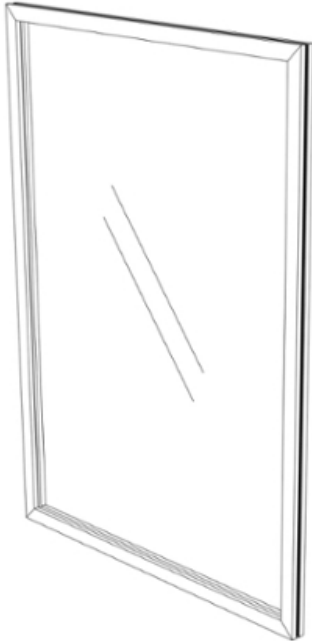

1.2



1.3



1.4

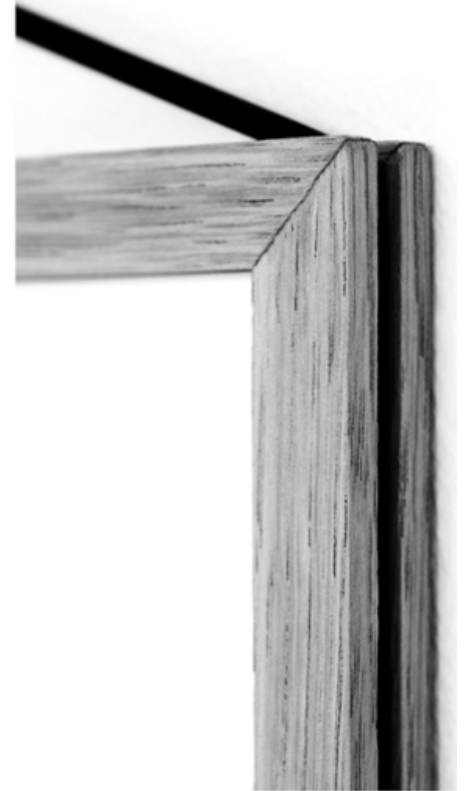

High risk that Inconsistencies be detected and
lead to a substantive refusal!

Don't confuse disclosure requirement and formal requirements !

- A single set of representations works for all Offices
- Offices cannot reject on formal grounds to:
 - Require, or oppose to surface shading or dotted line
 - Oppose to photographs, color or CADs
 - Require a description
 - Require a legend
- It's your liberty under the Hague to use these or not
- ... but using them or not has an impact on your disclosure



Avoiding possible refusals

Unity of Design

United States of America: A single design system

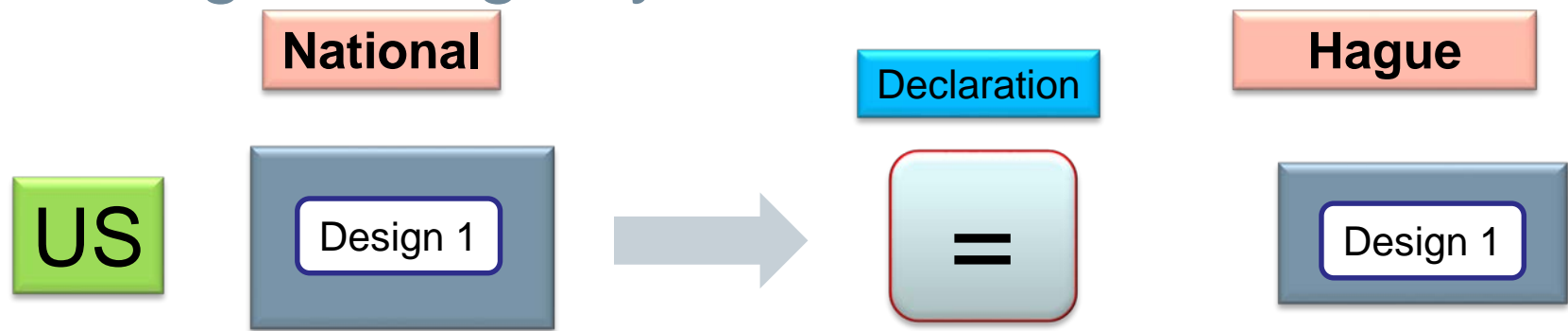

- ❑ **Declaration under Article 13(1):** Only one independent and distinct design may be accepted.
 - no examination by IB
 - possibility of refusal by USPTO based on this condition
 - any patentably distinct design should be eliminated.

- ❑ **Claim:** A single claim

- ❑ **Fee (Individual designation fee):**
A single fee, although different amounts apply according to the economic status of the applicant

US: Unity of Design

- Indistinct designs or obvious variations:
DM/086900: Designs 1-4, 7-11 “Toothbrushes”;
Designs 5-6 “Toothbrush heads”

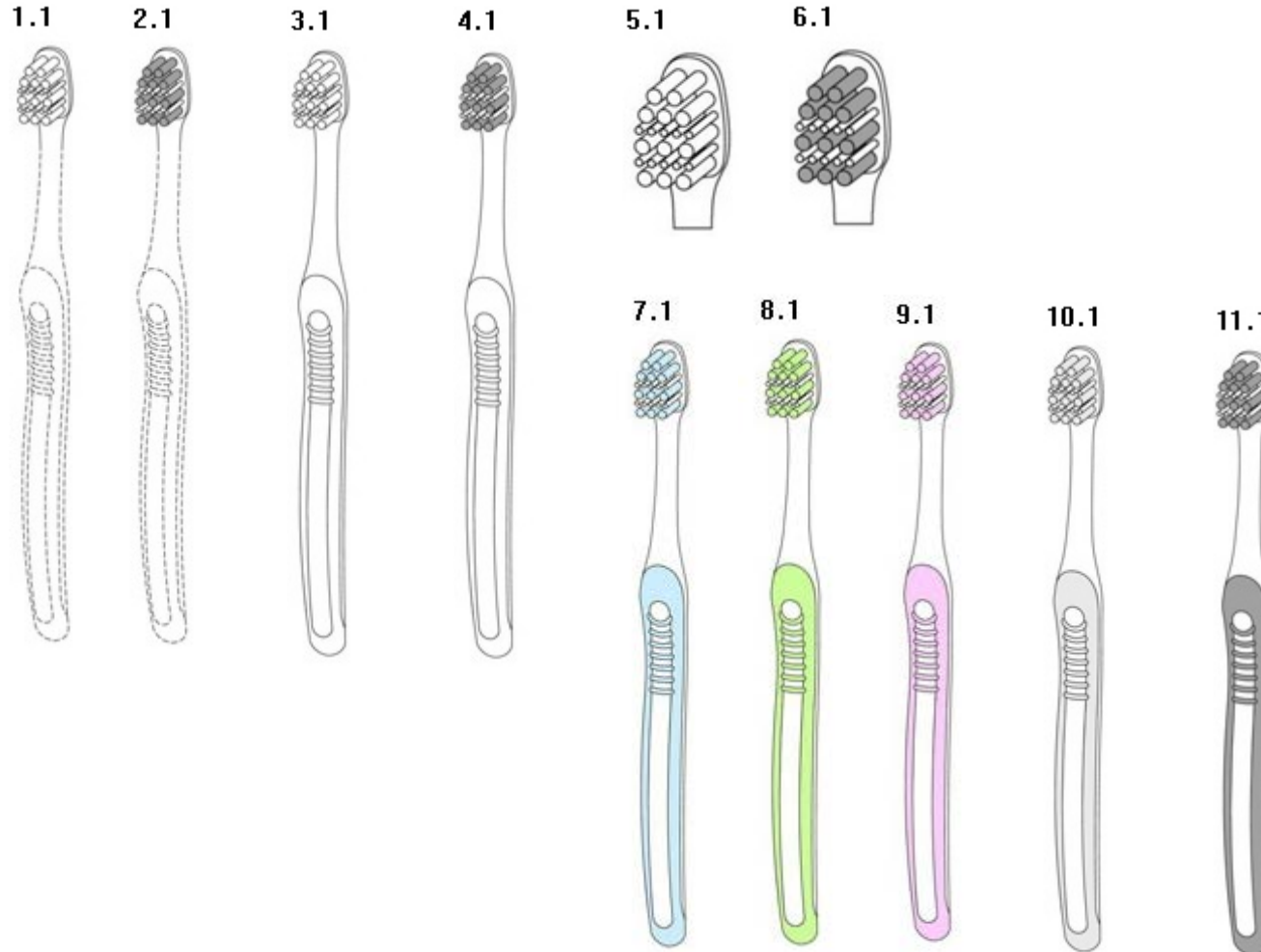

WIPO FOR OFFICIAL USE ONLY

Unity of Design

- Indistinct designs or obvious variations:

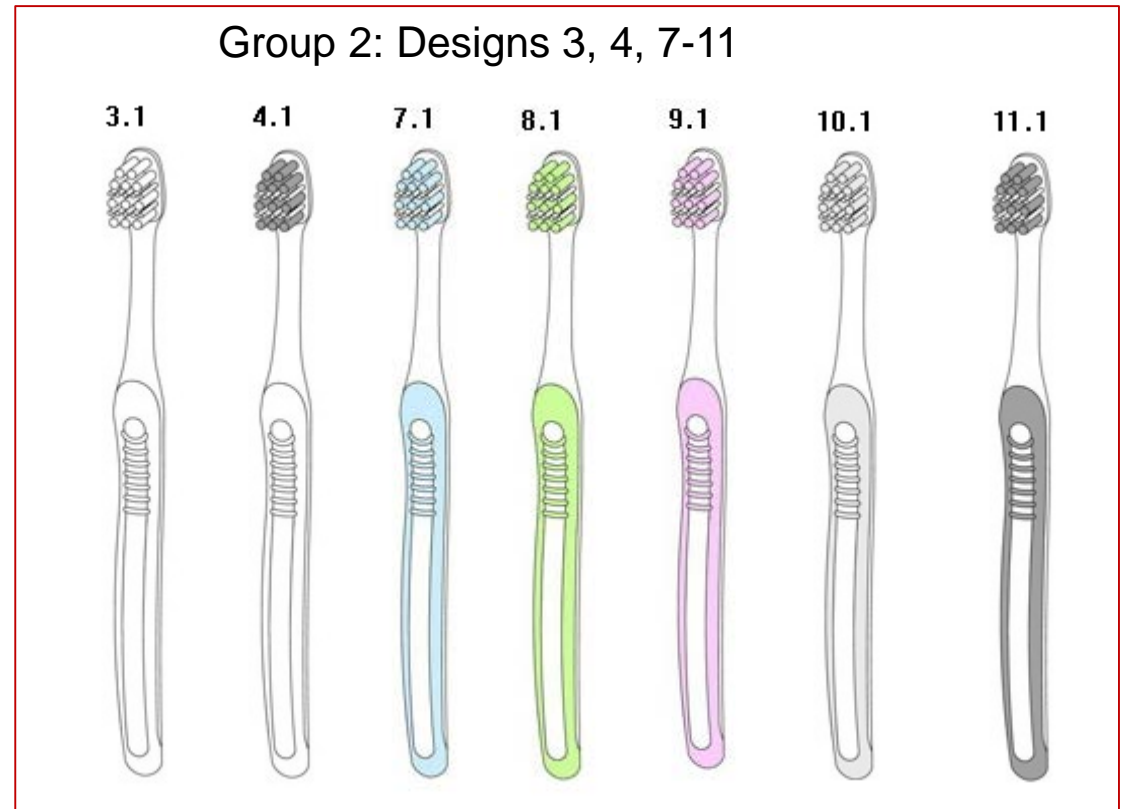
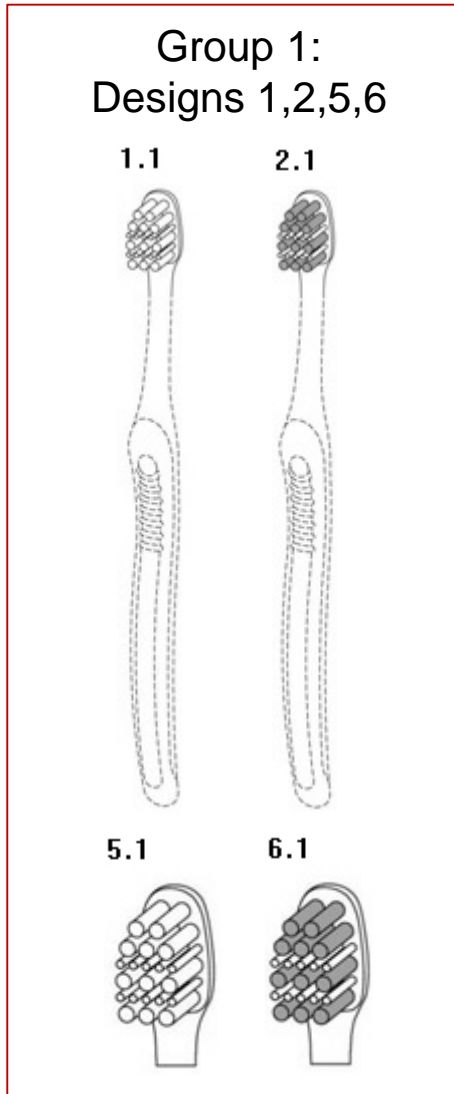

Designs grouped together have the same basic design characteristics:

- similar in overall appearance
- similar in visual impression
- similar in shape/ configuration

Declaration under Article 13(1): RU

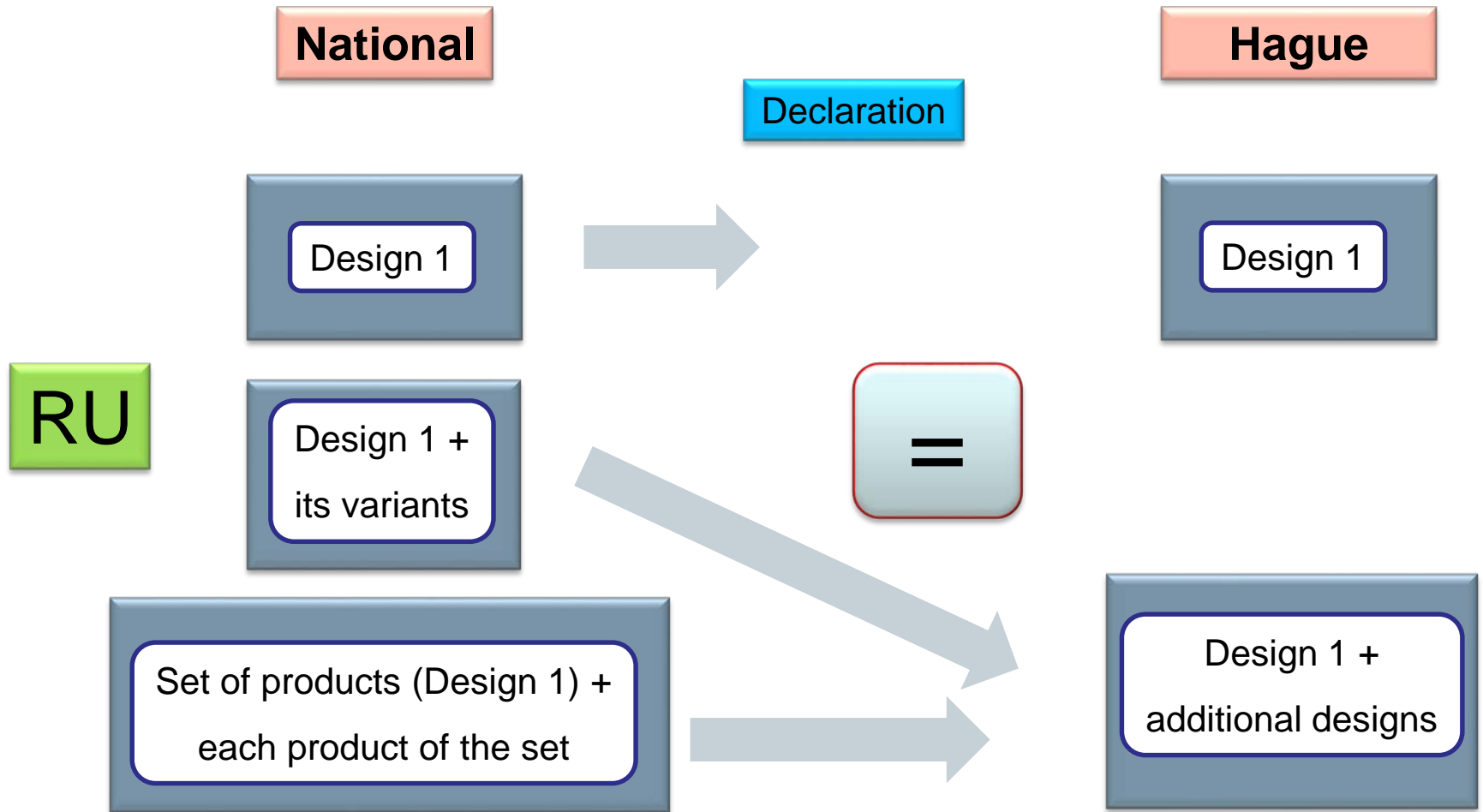

The variants of the design claimed shall visually differ from it and from each other by minor distinctions and/or by combination of colors.

RU: Unity of design requirement

Independent and distinct design



Set of designs,
each product of the set
may be included into the same IR



Independent and distinct design
and its variants



DM/088200: Notification of refusal on the ground of lack of unity of design by JPO

- Design No. 1 includes two or more designs judged by the national examination standard, JPO issued a NoR on the ground of lack of unity of design.
- In such a case, if the holder deletes either of them, protection can be granted to the amended design. At the same time, the holder may file divisional national application(s) for the deleted design(s), keeping the filing date.
- SGP following refusal issued by the JPO (for the amended design)

LANCÔME PARFUMS ET BEAUTE & CIE
PARIS (FR)

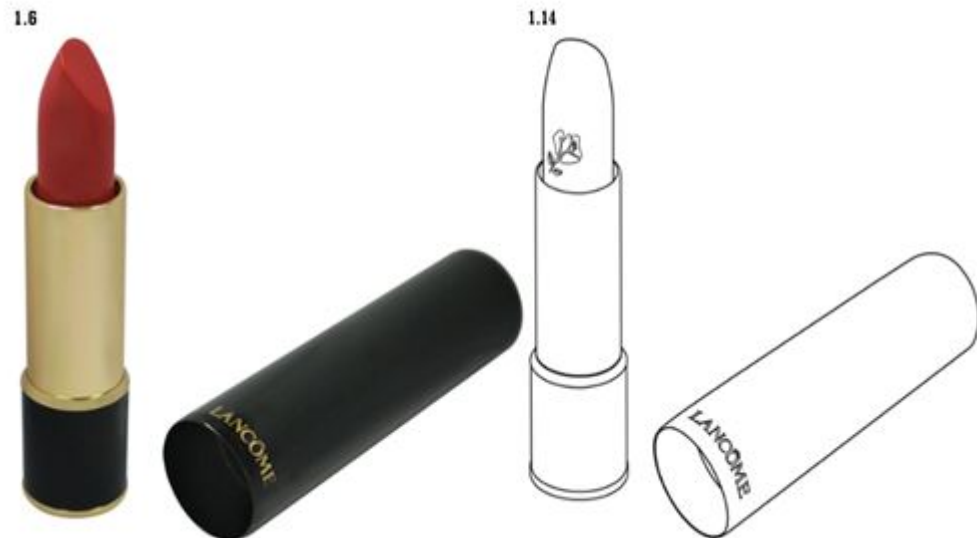



Avoiding possible refusals:

Conflict application/registration

What is related design?

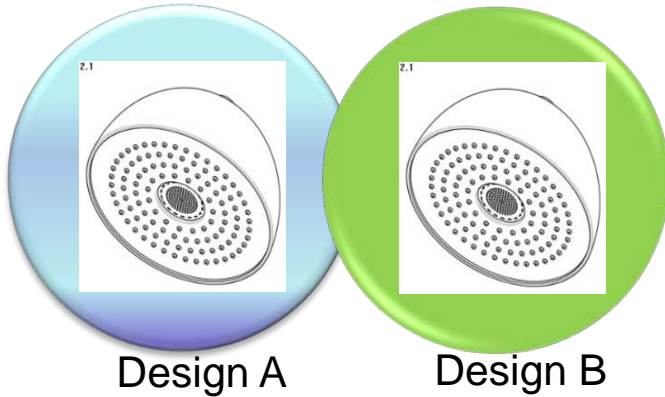

- Similar
- Filed by the same applicant
- Filed in appropriate duration

Principal design

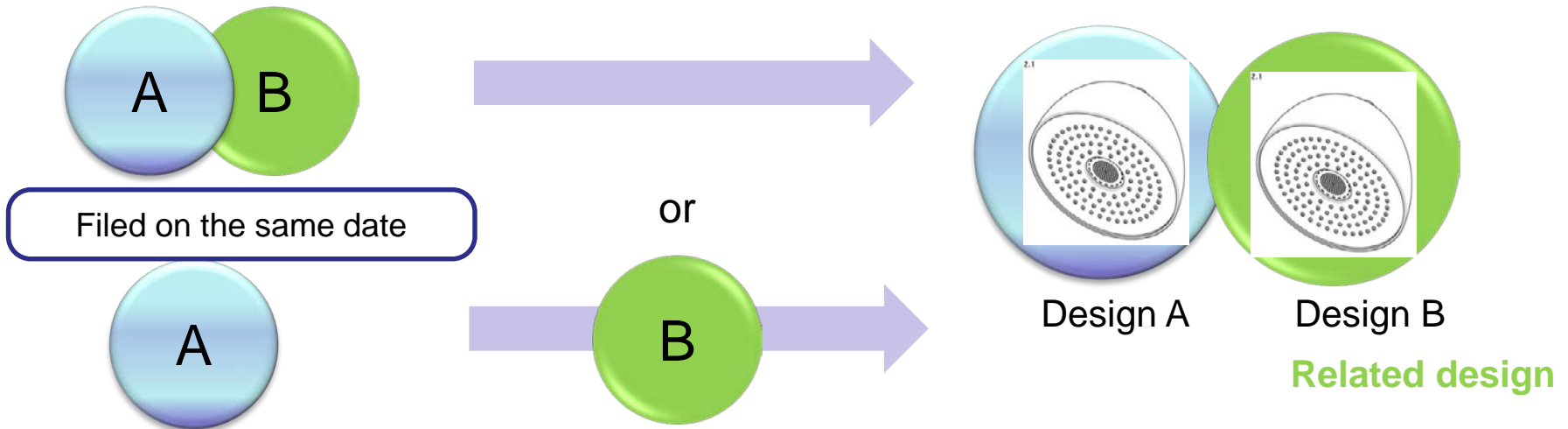

KR: filed within 1 year from the filing date of Design A

JP: after the filing date and before the date of publication for design registration of Design A in JP

Identify the Principal and Related Designs in the dedicated eHague tab

1.1

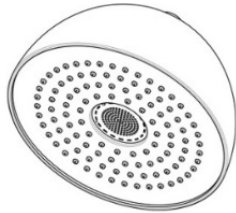

2.1

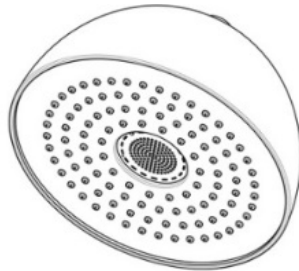

1.1

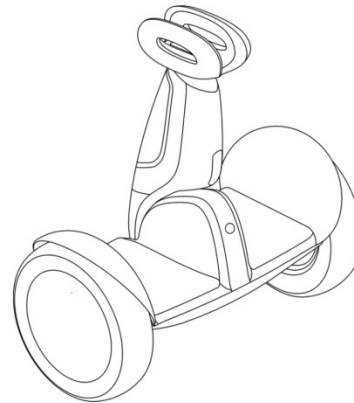

2.1



...think about it even if the first design was filed in another Hague or domestic application!



Avoiding possible refusals:

Lack of novelty

Exception to lack of novelty: KR, JP

Disclosure of Design A

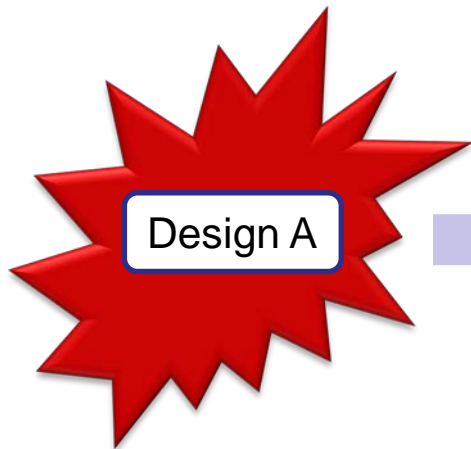

In an exhibition, published materials such as a magazine, catalog, or through the internet media, etc.

Filing of an IA

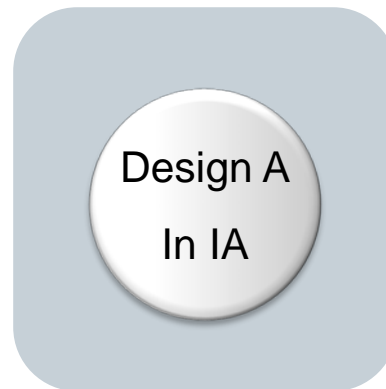

- Filing within 12 months from the date of disclosure
- With declaration concerning exception to lack of novelty

Examination by

JPO/KIPO

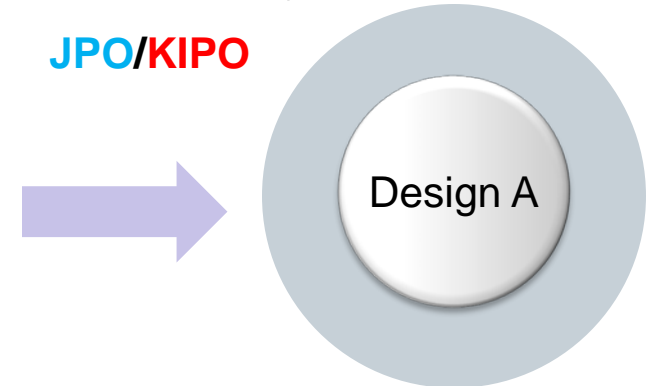

Disclosure of Design A does not become a reason for lack of novelty

Prior Divulgation

- KR: Attach documentation in support of a declaration concerning exception to lack of novelty under dedicated E-filing tab;
- JP: File original documentation in support of a declaration concerning exception to lack of novelty directly with JPO
- With respect to the designation of Japan, the Japan Patent Office (JPO) requires that the supporting documentation be submitted to it directly within 30 days from the date of publication of the international registration in the *International Designs Bulletin*.



Avoiding possible refusals:

Product Indication

Product indication: be as specific as possible

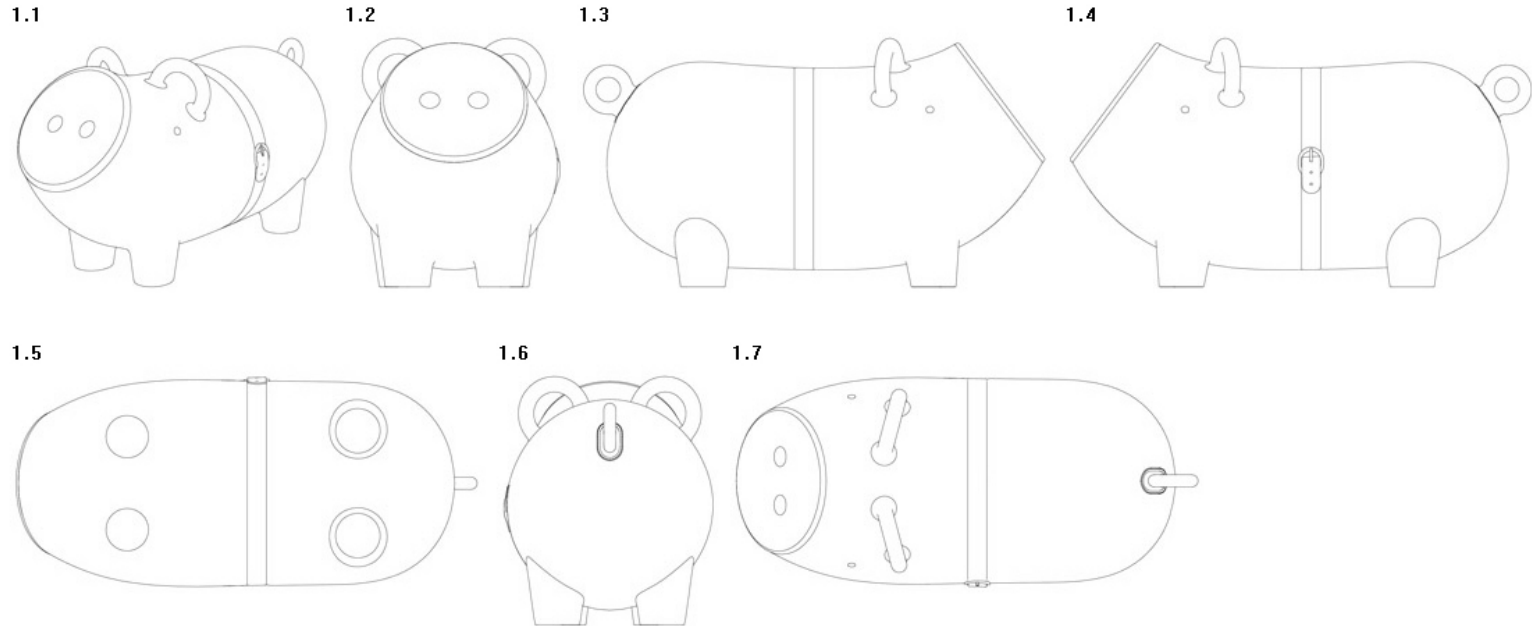

- JPO: «Toy» changed into «Riding Toy»
- Note: description *did* say «Toy to sit on in the form of a pig »...

Bear in Mind

- Japan and the Republic of Korea: Be Specific in the product indication

- Canada, Japan and the Republic of Korea: Do not file for logos under class 32



Avoiding possible refusals:

Submission of priority documents to JPO, KIPO and ROSPATENT

Submission of Priority Documents to JPO, KIPO and ROSPATENT

- KR: Attach your priority document under dedicated tab
 - JP: File your original priority document with JPO
 - ROSPATENT: File your priority document with ROSPATENT (a copy is accepted)

 - PAY ATTENTION TO DEADLINES for submission of priority documents! 3 months from the international publication date. No extension possible!
- ***Why don't you make the international application the priority application?***



Few Incentives...

Shy, still? Here are a few incentives...

- In the following examining jurisdictions:
JP, KR, RU, US
 - No provisional rights for domestic applications
- But provisional rights for IRs from the date of publication in the International Designs Bulletin!

Practical Advantages of the Hague System

- All steps of the procedure facilitated by effective online services (fee calculator, eHague, ePay, eRenewal, upload document function in Contact Hague)

- No need to appoint a foreign local representative at the time of filing (only if refused by the designated Office)

- Legal presumption of validity in non-examining jurisdictions is an advantage in case of conflicts
 - For sending cease and desist letters
 - In case of preliminary injunctions
 - Negotiating licences

Remember

- Think of Unity of Invention when designating US and RU
- Indicate your Principal & Related Designs in JP and KR
- Be specific in your product indication for JP and KR
- Disclosure, Disclosure, Disclosure

Using the Hague System to Get a Registered Community Design (RCD)

- No differences in the legal effects
- Some practical advantages
 - all views and description published in the International Designs Bulletin
 - cheaper to maintain
- **More importantly:** one-stop shop
 - Neighboring States of the European Union no luxury
 - Major markets (Canada, Japan, the Republic of Korea, the United States of America, the Russian Federation and China (coming))
 - **CA, EU, KR, JP, RU, US in the same application!!!**

Success Stories: these cases accepted by all Offices !

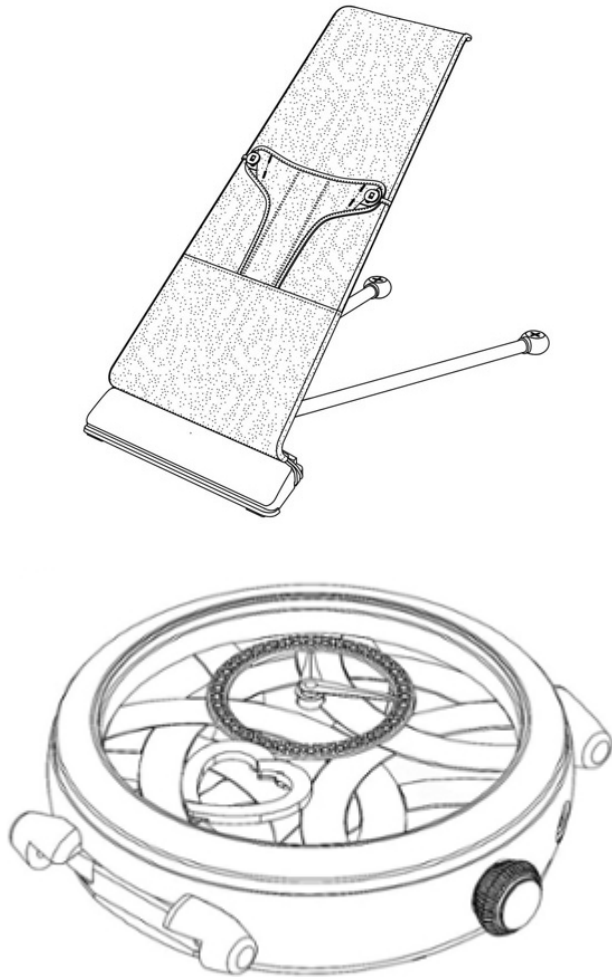

DM/89713 DM/92976 DM/90971
DM/89865 DM/89858 DM/89019

WIPO FOR OFFICIAL USE ONLY

WIPO | HAGUE
The International
Design System

Success Stories: these cases accepted by all Offices !

1.1

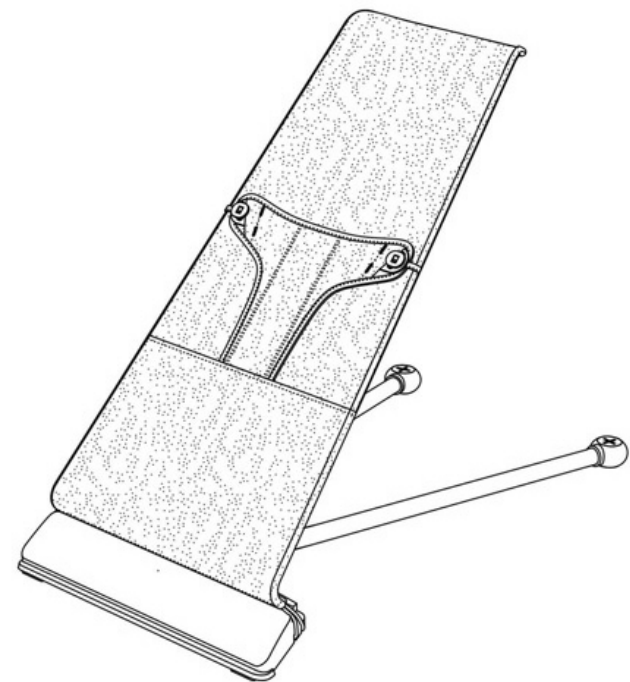

1.8

DM/89713
DM/88913
DM/86974
DM/87158
DM/87367

1.1



1.2

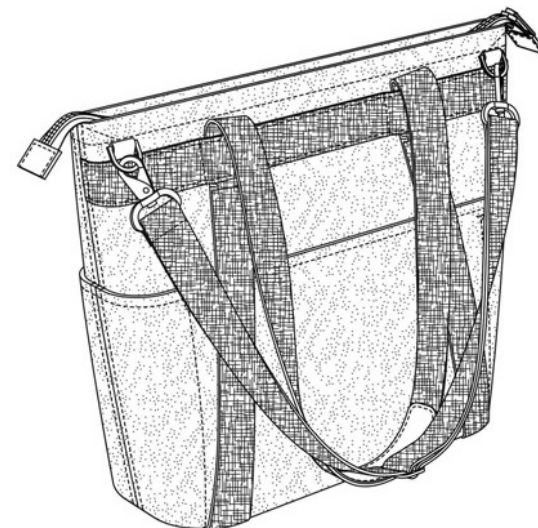
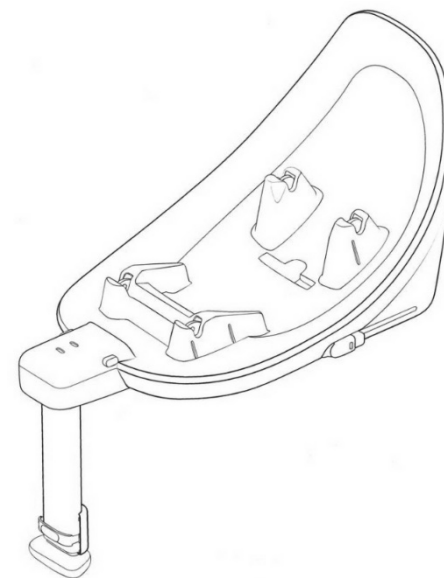

Thank you!



WIPO | HAGUE
The International
Design System

WIPO FOR OFFICIAL USE ONLY