



# WIPO FILE

Gregory Sadyalunda  
Project Manager, IP Offices Business Solutions Division

# What is WIPO File?

- A single online portal for local agents to file new patent, industrial design and trademark applications with supporting documents.
- It offers support for post-filing requests.
- It can be integrated with local payment and authentication systems
- It includes an optional fee calculation module

# WIPO File Pre-requisites

- IPAS running with EDMS enabled
- SMTP server for sending emails for user accounts verification
- Securing web portal with SSL certificate
- Application forms are digitally signed
- Two separate servers to host WIPO FILE public portal and back-end components
- Supported databases: Oracle, MS SQL Server, MySQL

# Features

- Management of local agents and office user accounts by IP Office
- Online filing services for local agents:
  - Preparing and submitting new application of industrial designs, patents and trademarks, with required supporting documents
  - Post-filing requests including renewal, payment of annuities, change of owner, change of representatives, amended claims, description, etc.
- Viewing, filtering, management of e-filing requests in portfolios and workbench
- Possibility to post Office notification letters in response to e-filing requests.

# Option to Enable Fees Calculation

- Filing fee calculation
  - Configure and view filing fee elements (type of service, fee and possible discounts)
  - Create, view and update fee payment tracking details (reference and amount)
- Process payment confirmations received from local banks

# Technical Arrangements

- Application documents are created by merging application form and supporting documents in PDF format only
- Logos and drawings for designs and patents are transferred to IPAS database but not EDMS
- Transmission receipts are stored in WIPO FILE
- Lookup on existing IPAS File numbers, registration numbers, expiration dates and annuities

# What the IP Office needs to prepare

- Design request form templates and transmission receipt templates
- Define new user documents (e.g. patent specification, SME certificate)
- Acquire server digital certificates (SSL) and client digital certificates for secure access authentication and electronic signatures
- Assign one public IP address to the WIPO File public portal
- Configure firewalls rules to protect the WIPO File public portal and back-end system
- Optionally configure fee calculation rules
- Training for local agents

# Business Use Case with an External Payment Gateway

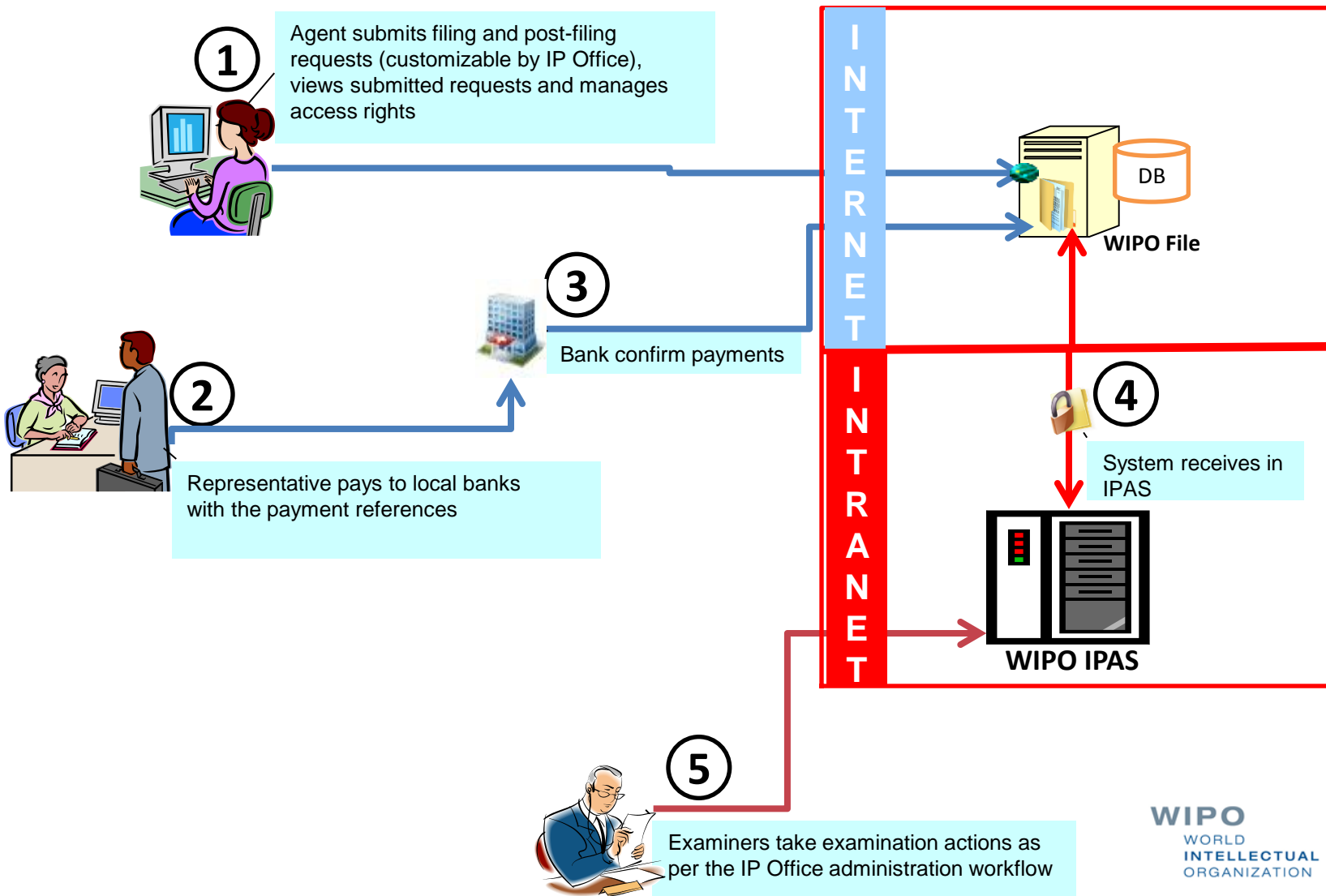



# Business Use Case without Payment Gateway

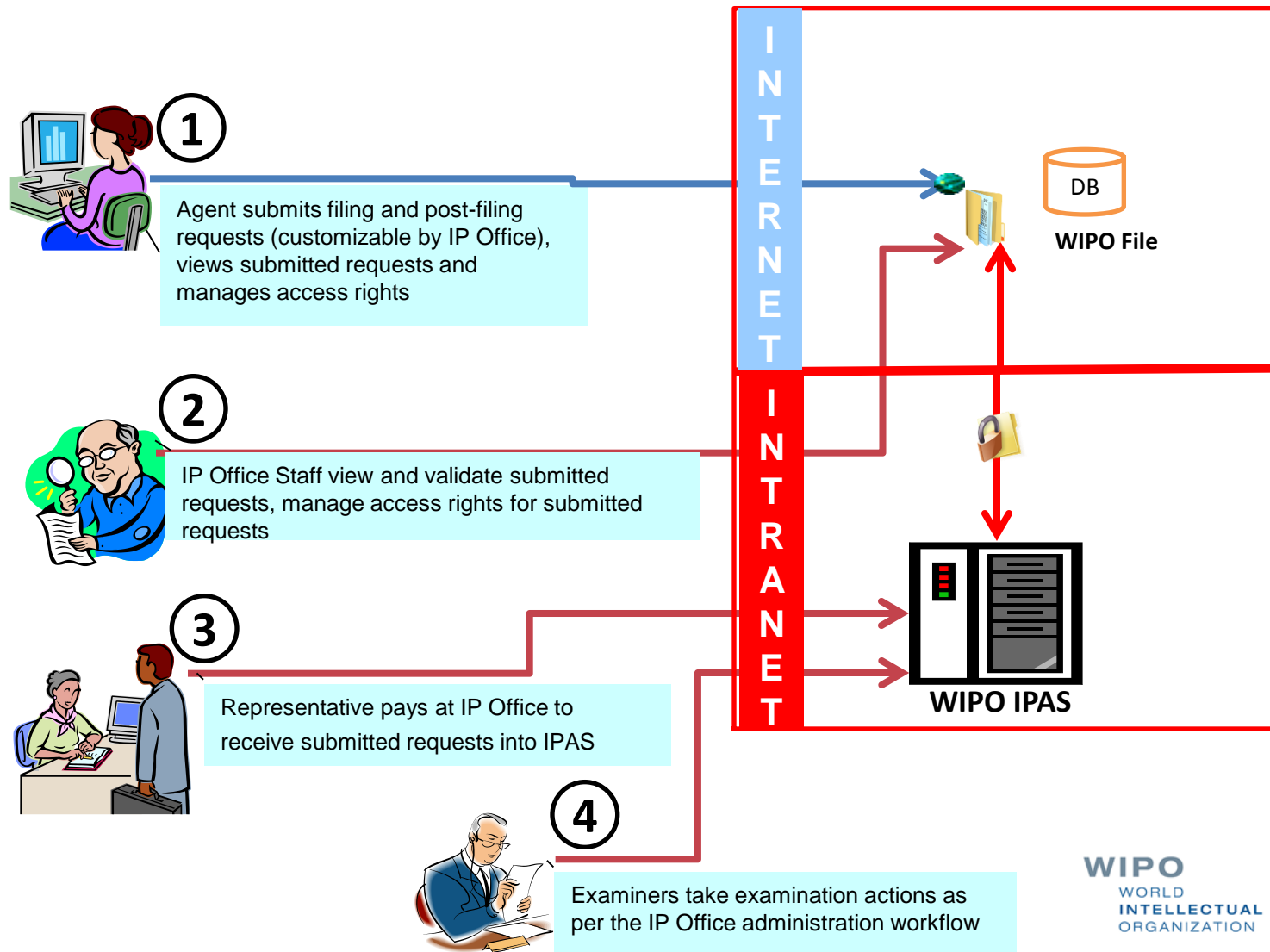

# WIPO File Demo

Thank You.